

# Projet DESI Mesure de la transmission du spectrographe EM#1

Laurent Le Guillou (UPMC/LPNHE)

*LPNHE, Réunion du Vendredi  
2017-09-08*

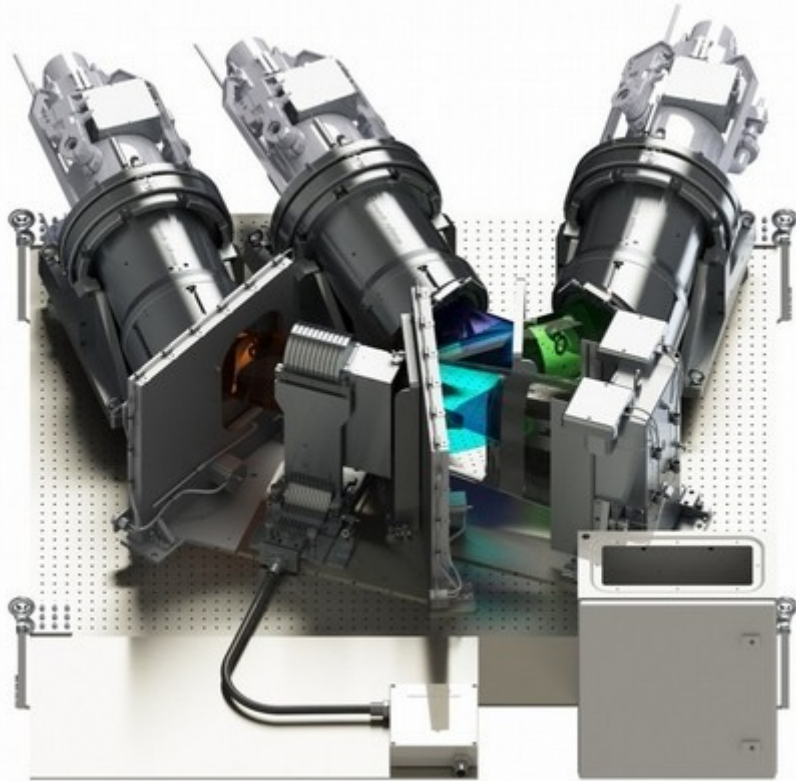

LPNHE : Julien Coridian, Patrick Ghislain, Julien Guy, Sonia Karkar, Laurent Le Guillou,  
Yann Orain, Philippe Repain, Michael Roynel, Eduardo Sepulveda  
AMU : Pierre-Eric Blanc, Sandrine Perruchot, Xavier Regal, Samuel Ronayette



**Dark Energy Spectroscopic Instrument**

Laurent Le Guillou (UPMC/LPNHE)  
LPNHE, Réunion du Vendredi, Paris, 2017-09-08

1 / 91

# Talk outline

- Introduction: the DESI project
- eBOSS/DESI Team at LPNHE
- Throughput Measurement: Principles
- Flux Calibration Device for the Test Fiber Slit
- Measurement Campaigns
- Data Analysis
- Focal Ratio Degradation (FRD) estimate (on going)
- Results, Conclusions and Perspectives



# Talk outline

- **Introduction: the DESI project**
- eBOSS/DESI Team at LPNHE
- Throughput Measurement: Principles
- Flux Calibration Device for the Test Fiber Slit
- Measurement Campaigns
- Data Analysis
- Focal Ratio Degradation (FRD) estimate (on going)
- Results, Conclusions and Perspectives



# BAO : Oscillations Acoustiques de Baryons

dans le CMB à  $z \sim 1000$

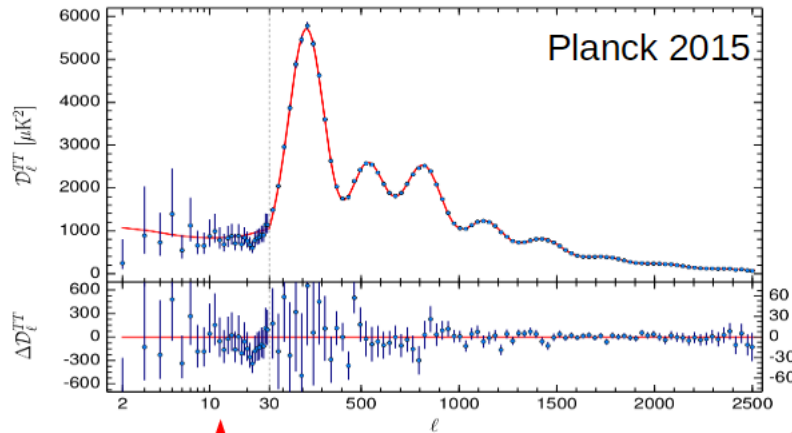

dans la forêt Lyman-alpha à  $z \sim 2.3$

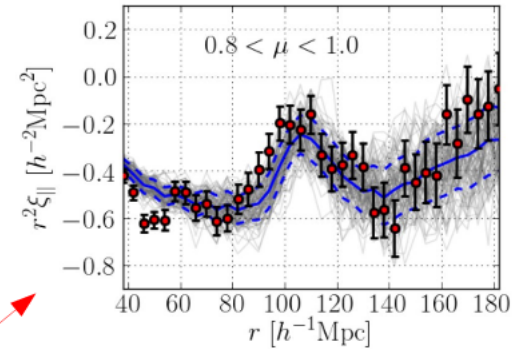

dans le champ de densité des galaxies

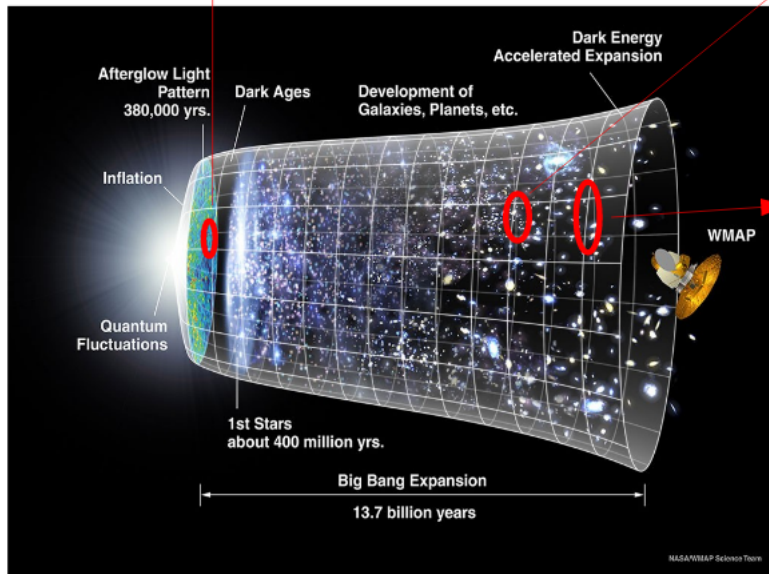
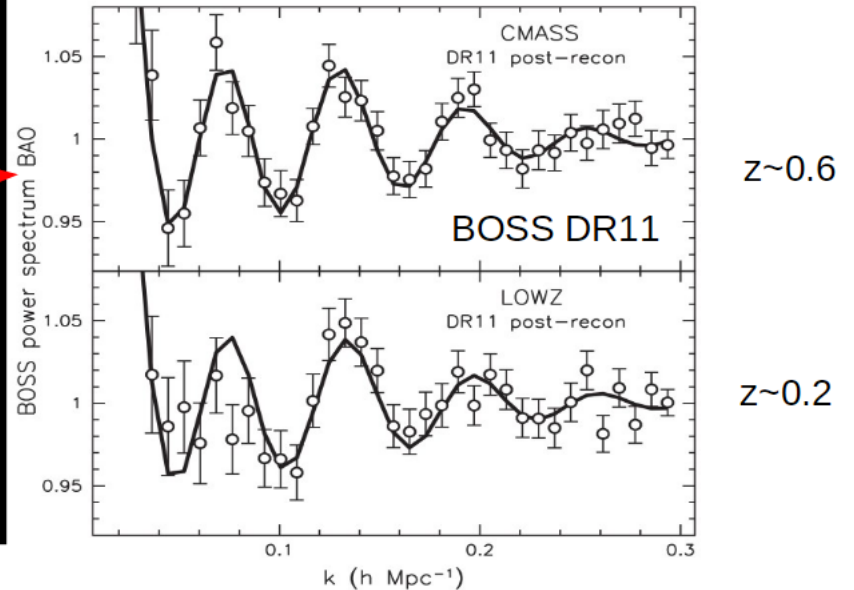

Dark Energy Spectroscopic Instrument

Laurent Le Guillou (UPMC/LPNHE)  
LPNHE, Réunion du Vendredi, Paris, 2017-09-08



# DESI: Dark Energy Spectroscopic Instrument

- 4m Mayall (Kitt Peak)
- 10 spectrographs
- 10 x 500 fibers
- First light ~2019

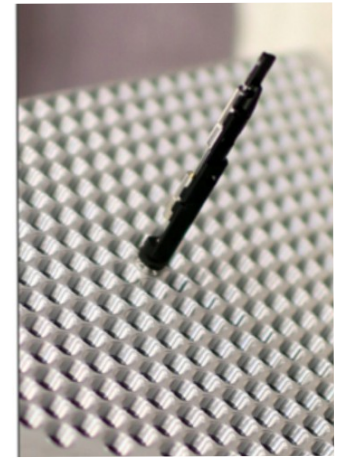
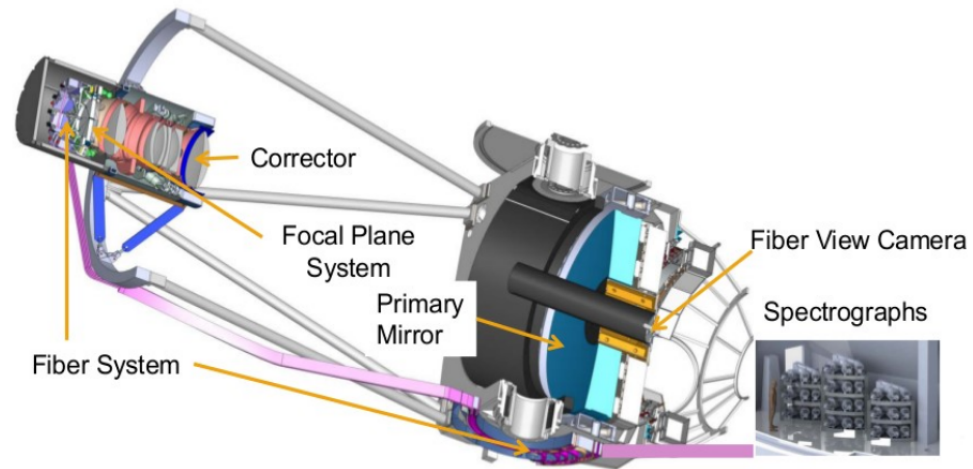
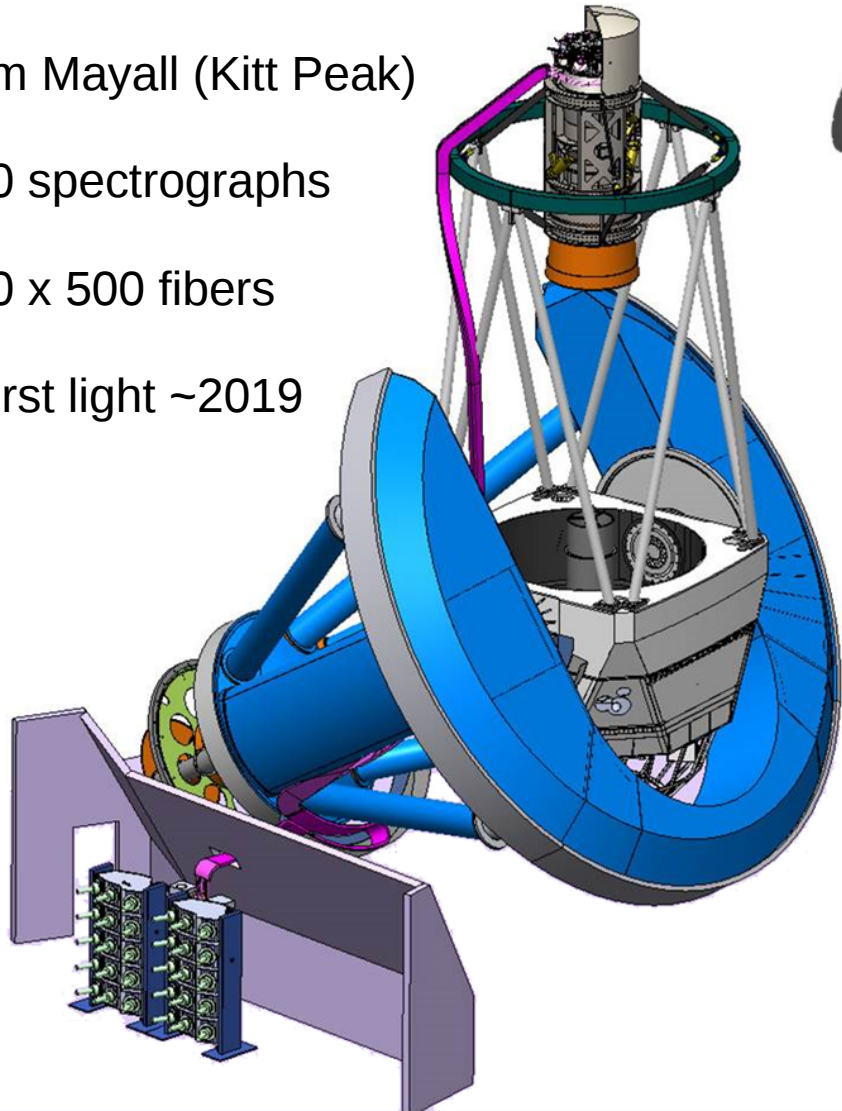

# DESI: Dark Energy Spectroscopic Instrument

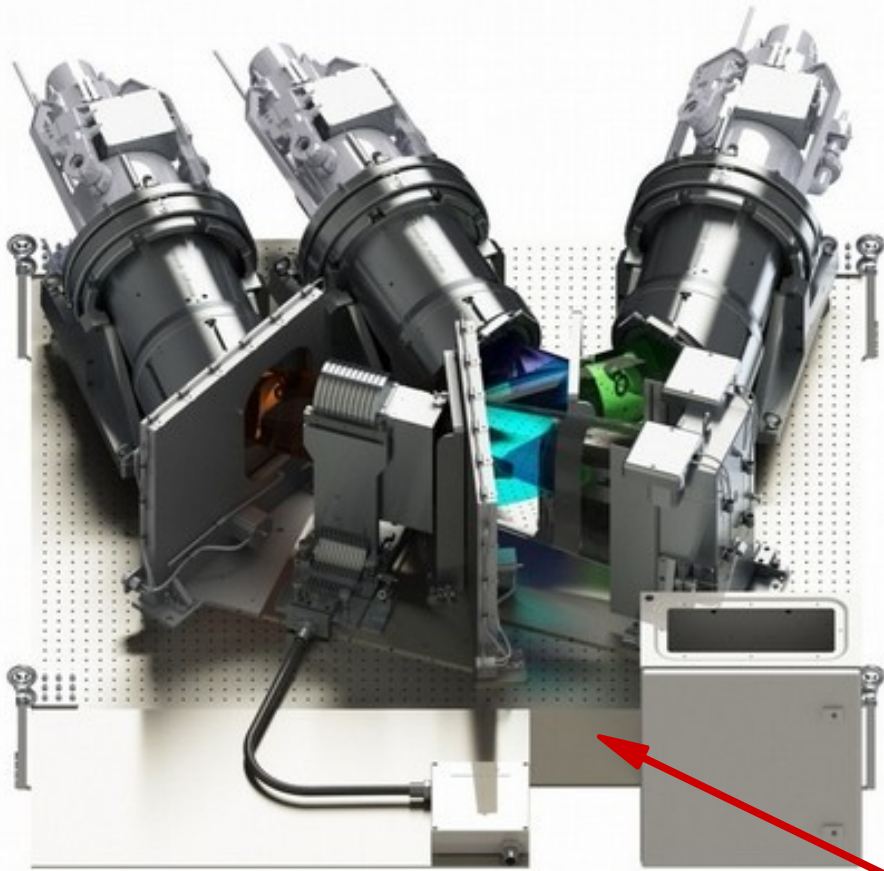

- 10 spectrographs
- 3 arms (B,R,Z/NIR)  
350 - 1000 nm

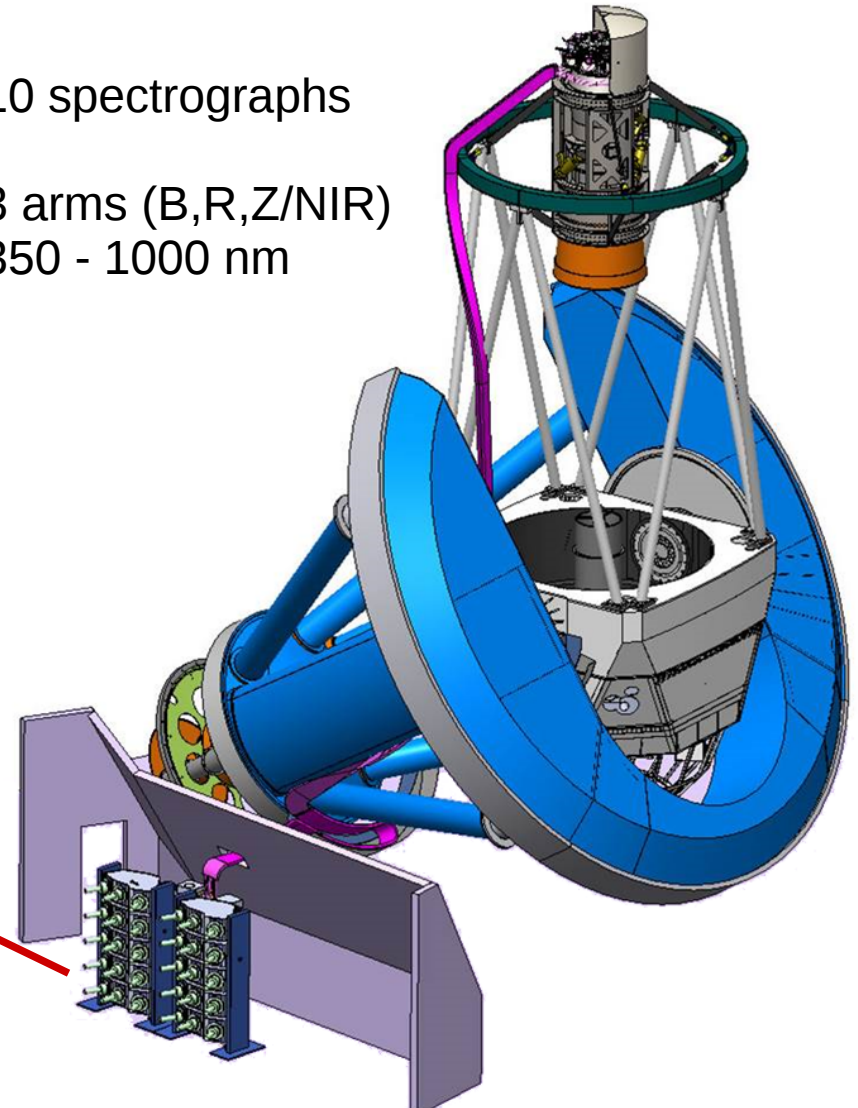



# DESI spectroscopic survey 14000 deg<sup>2</sup>

The largest spectroscopic survey for dark energy

SDSS  $\sim 2h^{-3}\text{Gpc}^3$   $\rightarrow$  BOSS  $\sim 6h^{-3}\text{Gpc}^3$   $\rightarrow$  DESI  $50h^{-3}\text{Gpc}^3$

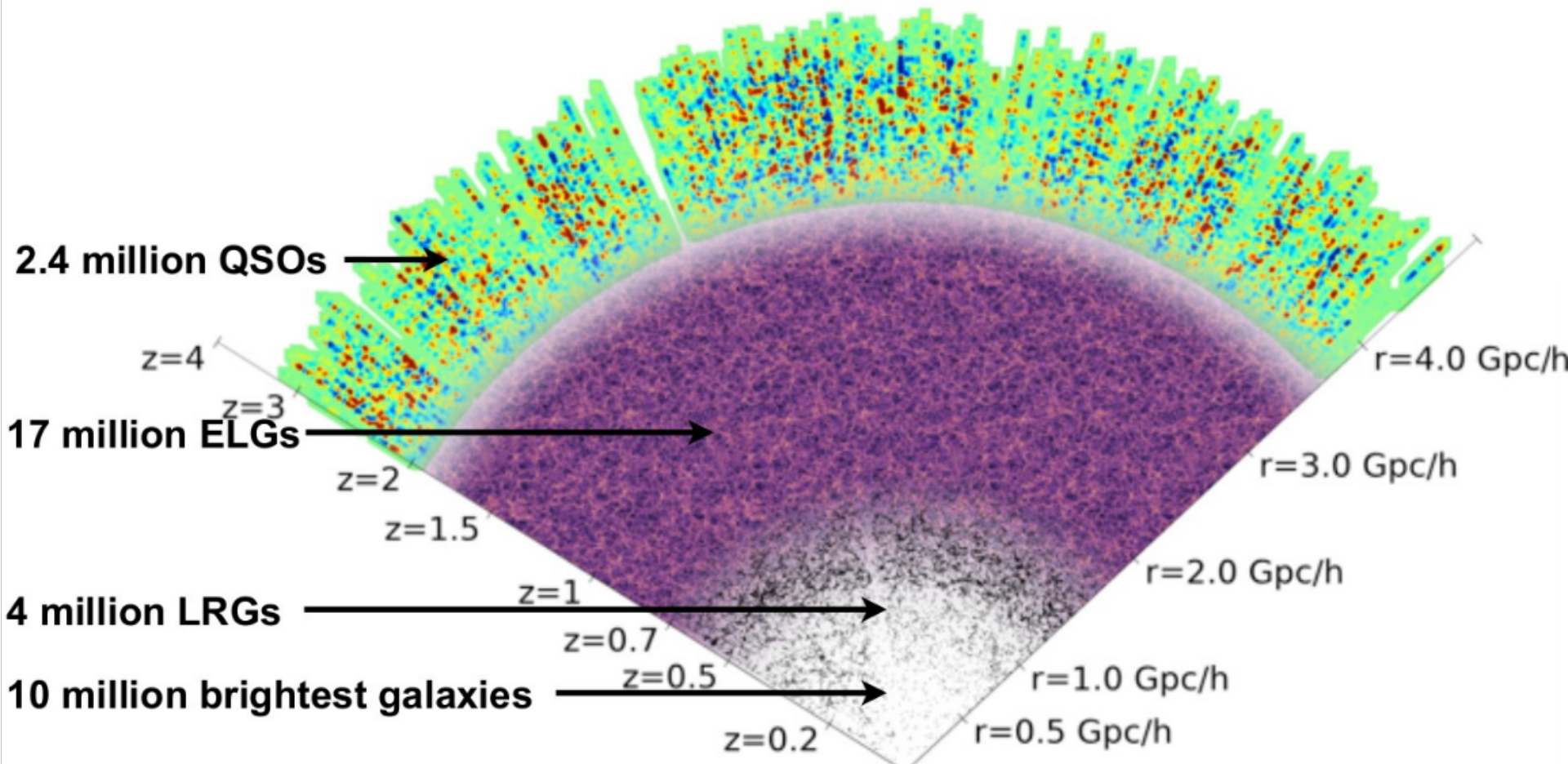

# Contraintes sur $H(z)$

BOSS+eBOSS+DESI

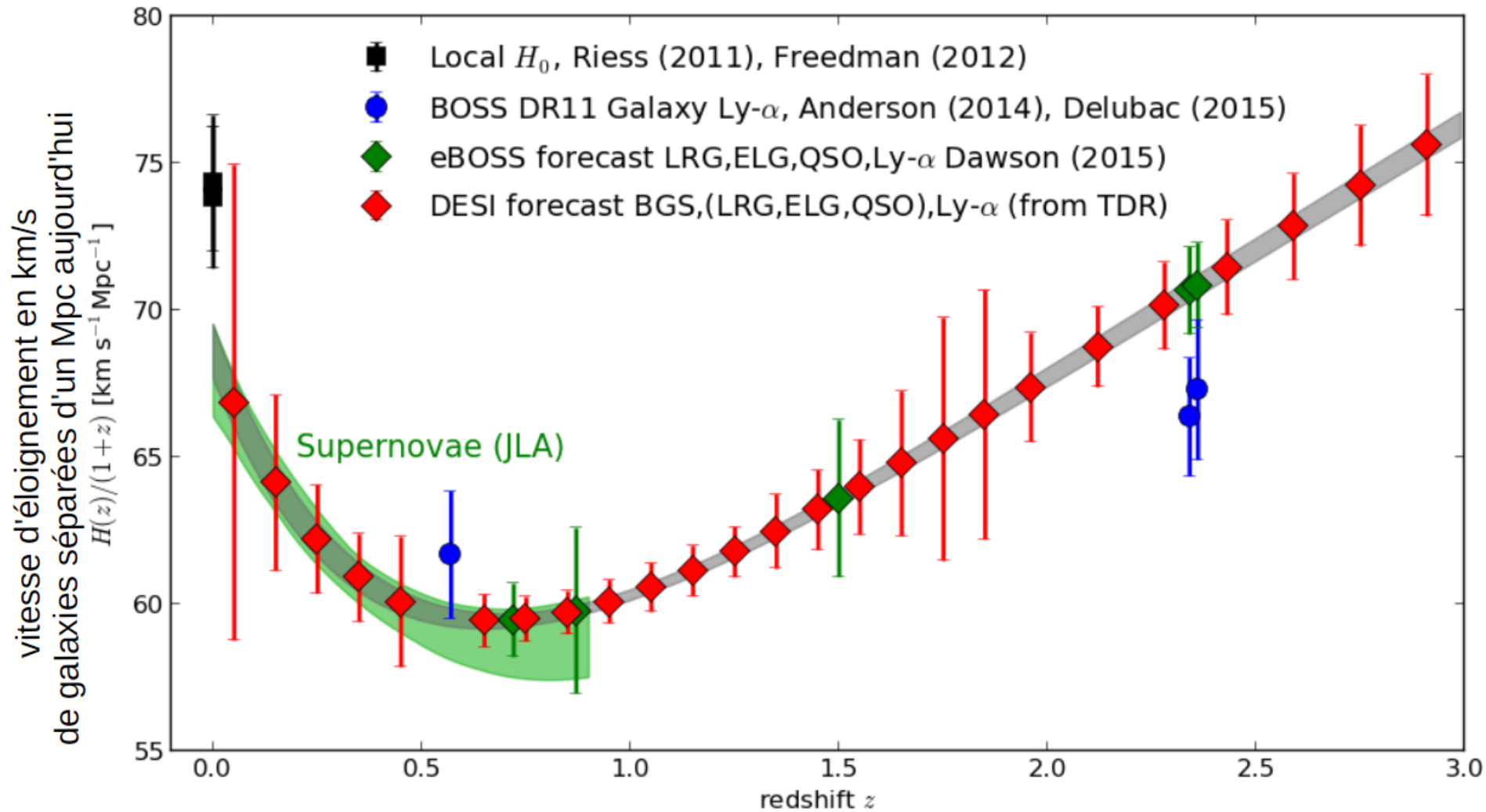

# Talk outline

- Introduction: the DESI project
- **eBOSS/DESI Team at LPNHE**
- Throughput Measurement: Principles
- Flux Calibration Device for the Test Fiber Slit
- Measurement Campaigns
- Data Analysis
- Focal Ratio Degradation (FRD) estimate (on going)
- Results, Conclusions and Perspectives



# BAO au LPNHE : eBOSS & DESI ( $\Rightarrow$ "COEN")



Victoria de Ste-Agathe  
Doctorante ILP



Julien Guy



Christophe Balland



Laurent Le Guillou

**eBOSS**



Hector Gil-Marin  
Post-doctorant ILP



Nicolas Busca



Sonia Karkar

**DESI**





# Contributions techniques décisives

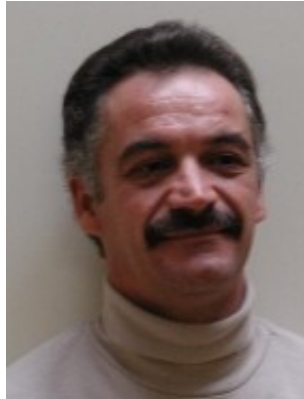

Patrick Ghislain



Philippe Repain



Eduardo Sepulveda



Julien Coridian



Yann Orain

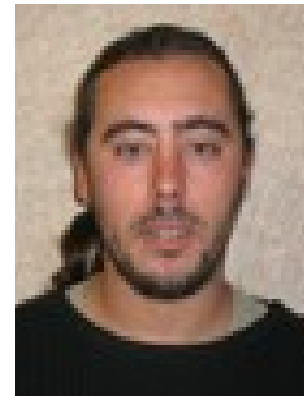

Michael Roynel



# Talk outline

- Introduction: the DESI project
- eBOSS/DESI Team at LPNHE
- **Throughput Measurement: Principles**
- Flux Calibration Device for the Test Fiber Slit
- Measurement Campaigns
- Data Analysis
- Focal Ratio Degradation (FRD) estimate (on going)
- Results, Conclusions and Perspectives



# Le spectrographe DESI

- 10 identical spectrographs
- 10 x 500 fibers
- 3 arms :  
NIR, Red, Blue

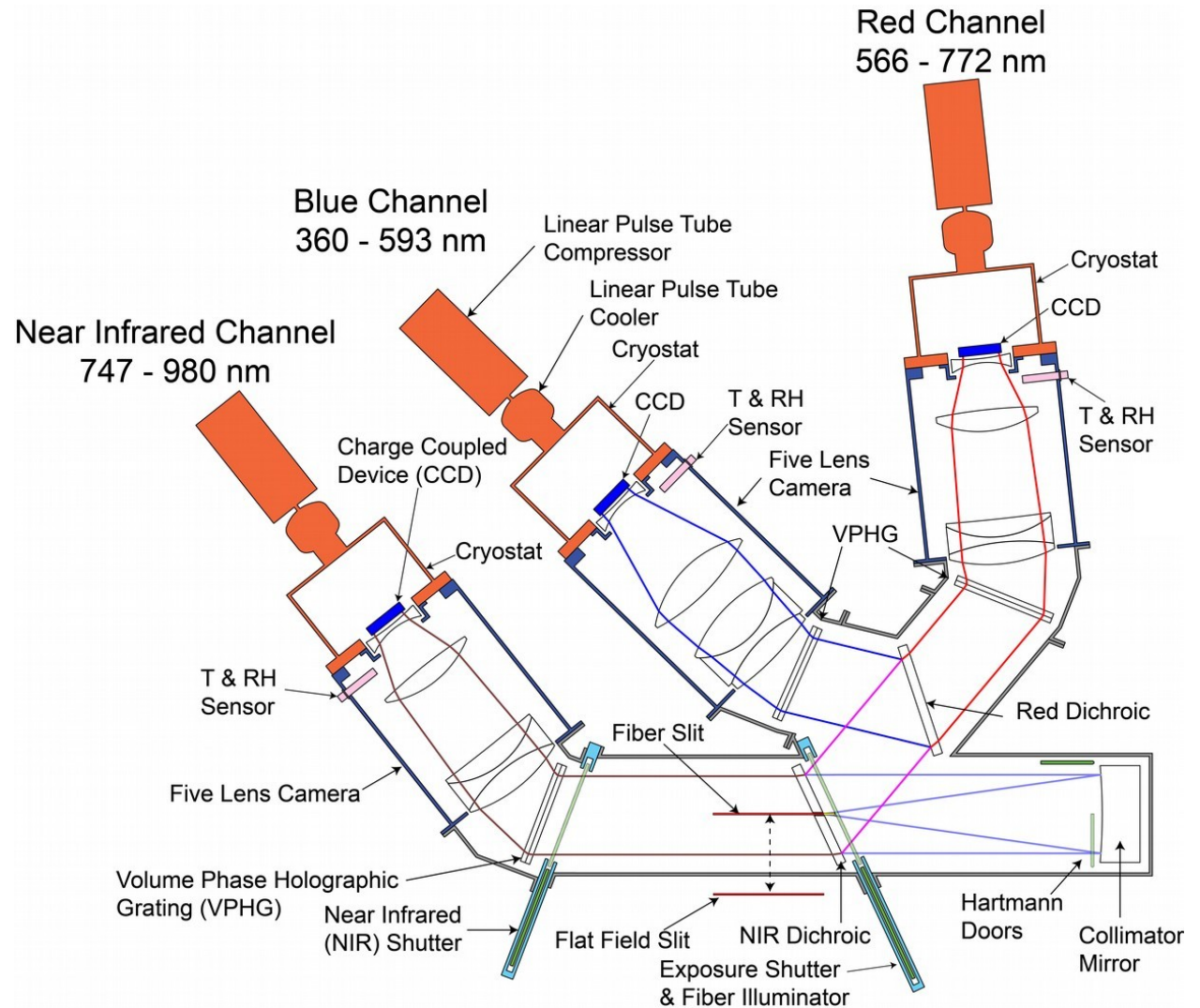

# Le spectrographe DESI

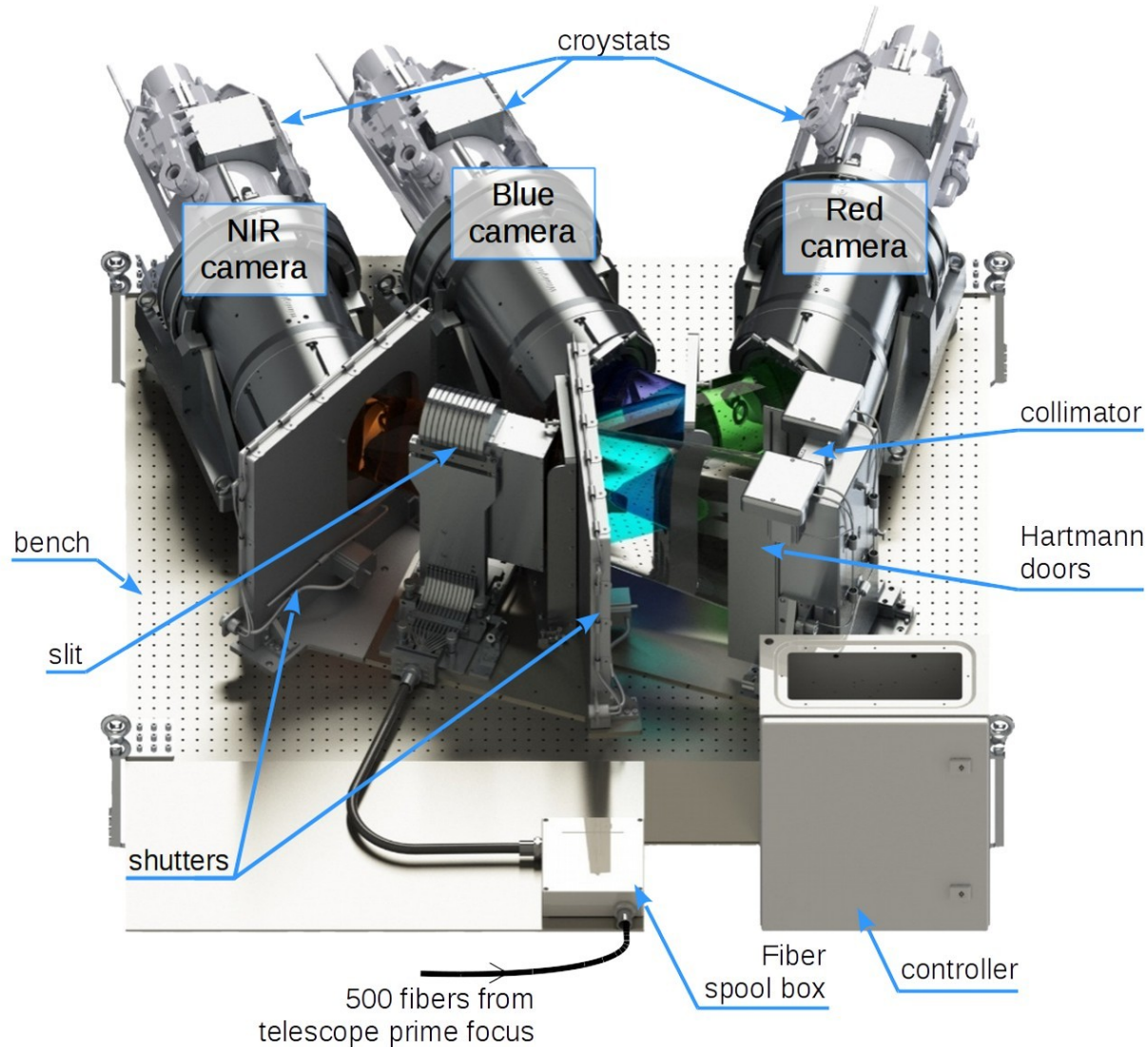



# Le spectrographe DESI (sans baffling)

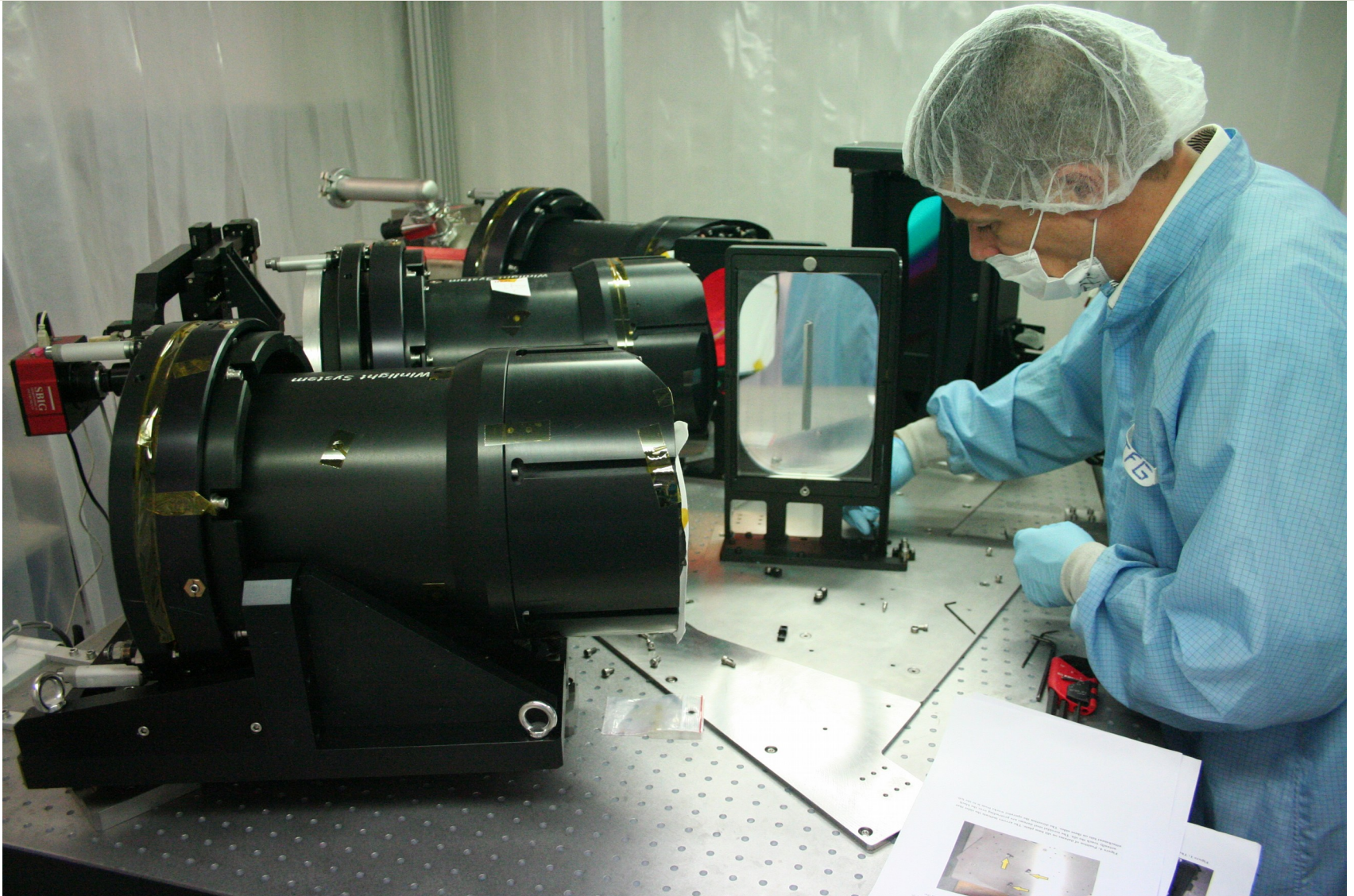

**Dark Energy Spectroscopic Instrument**

Laurent Le Guillou (UPMC/LPNHE)  
LPNHE, Réunion du Vendredi, Paris, 2017-09-08

15 / 91



# Banc d'injection dédié (AMU@Winlight)

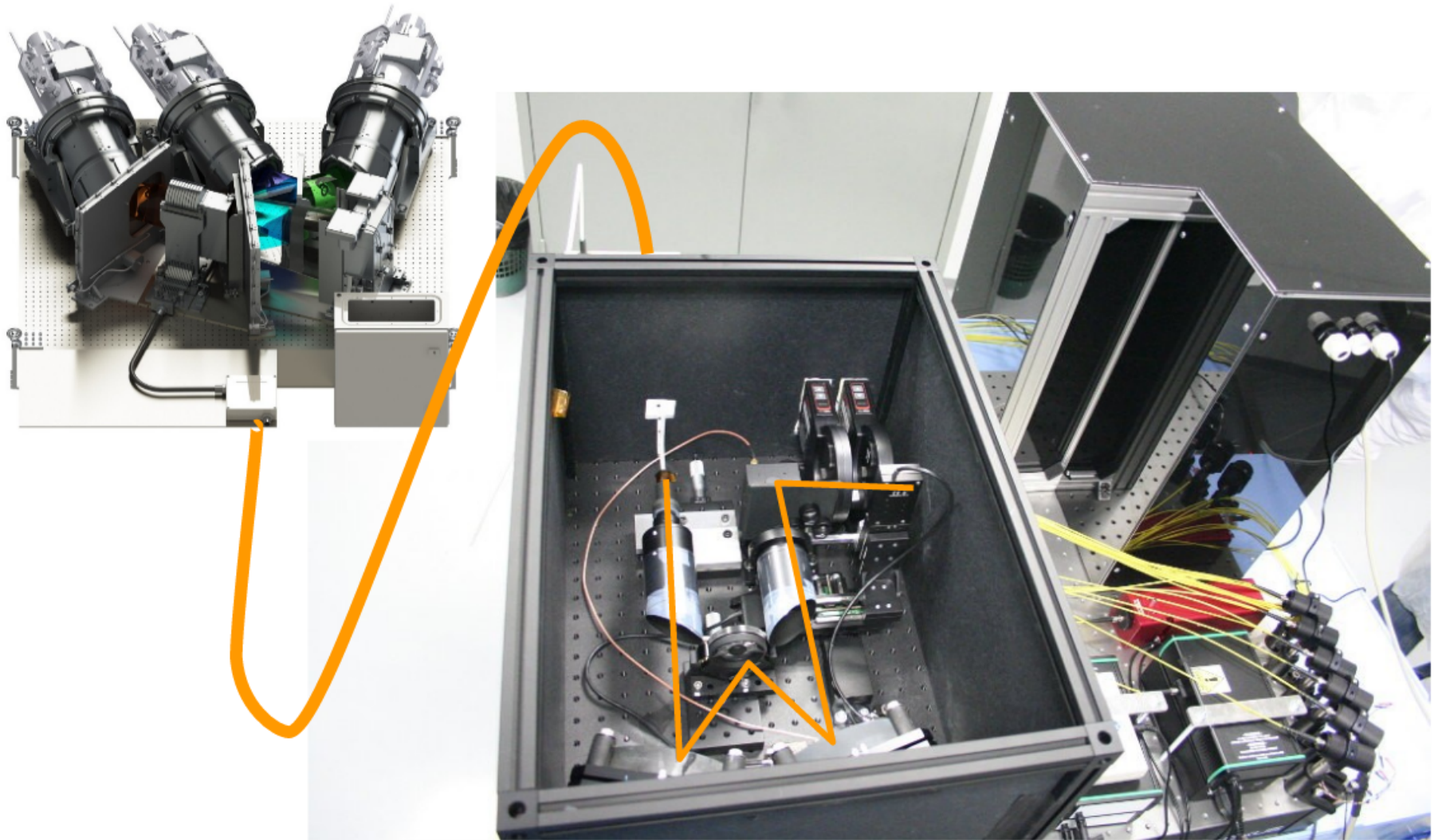

**Dark Energy Spectroscopic Instrument**

Laurent Le Guillou (UPMC/LPNHE)  
LPNHE, Réunion du Vendredi, Paris, 2017-09-08

16 / 91



# Banc d'injection dédié (AMU@Winlight)

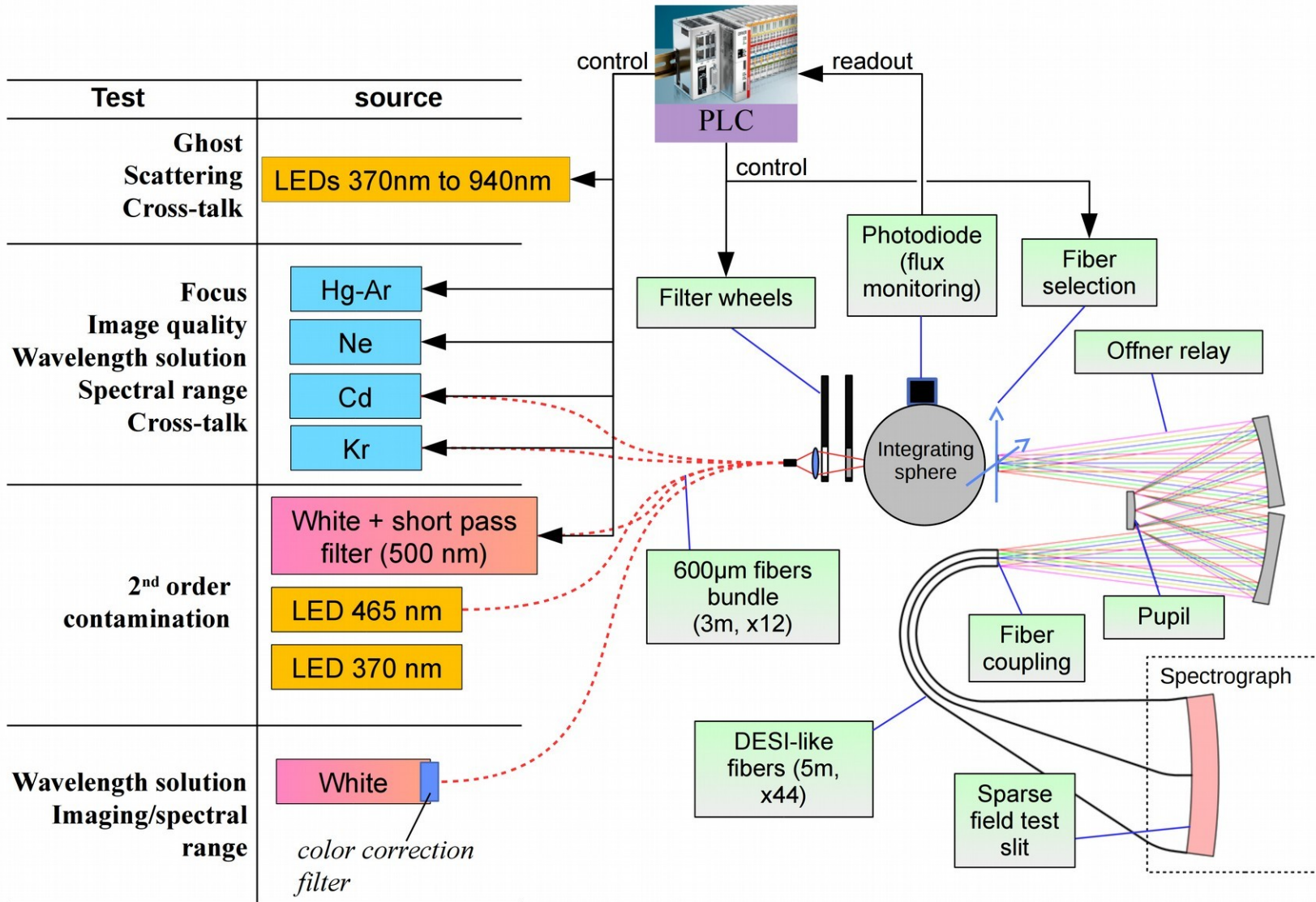

# “sparse fiber slit(s)”: illumination fibre unique

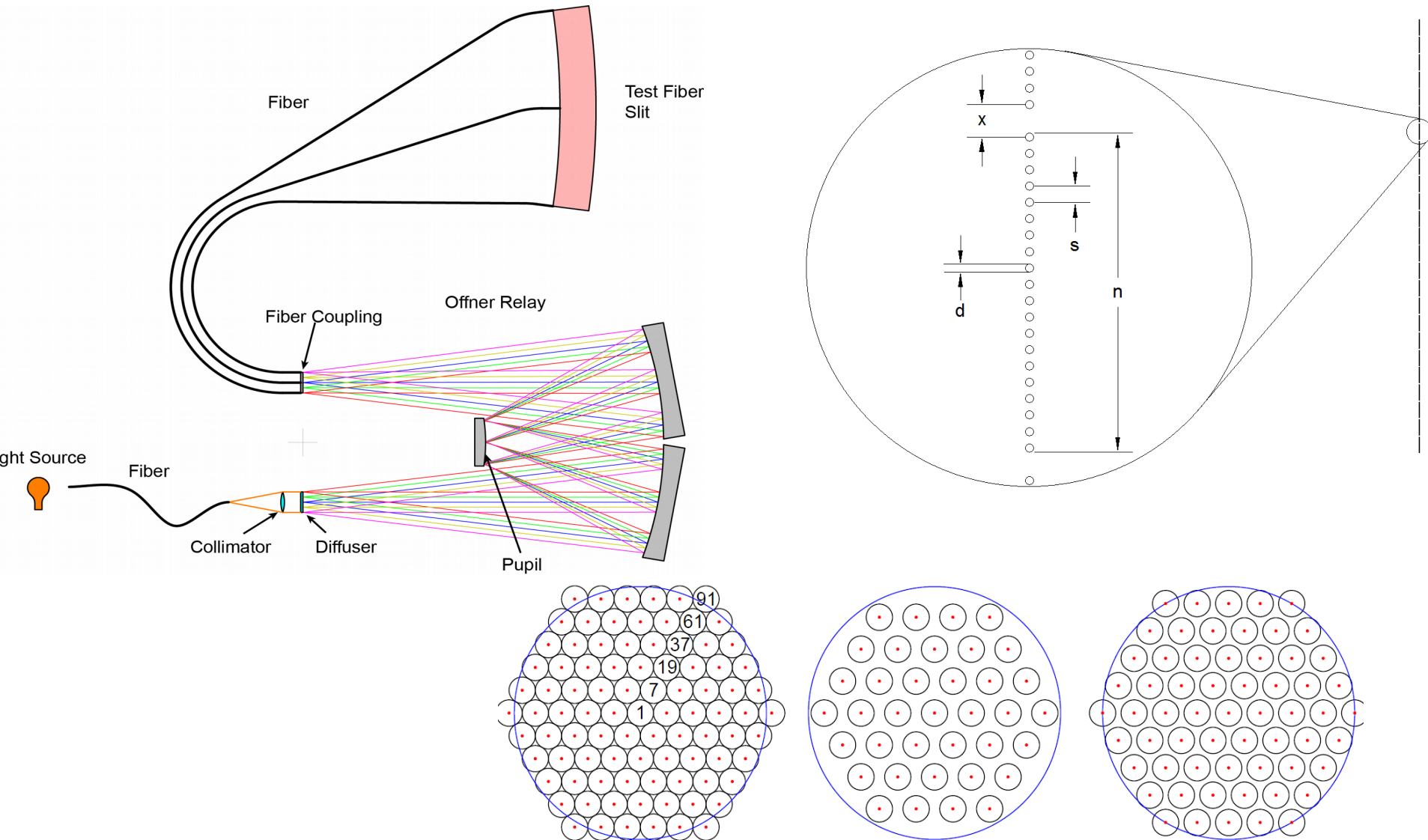

# Fiber slit(s): “sparse fiber slit”

- 21 well separated fibers
- May be illuminated individually (AMU bench)

Fiber :  $f/3.57$   
Angle  $\theta \sim 8^\circ$

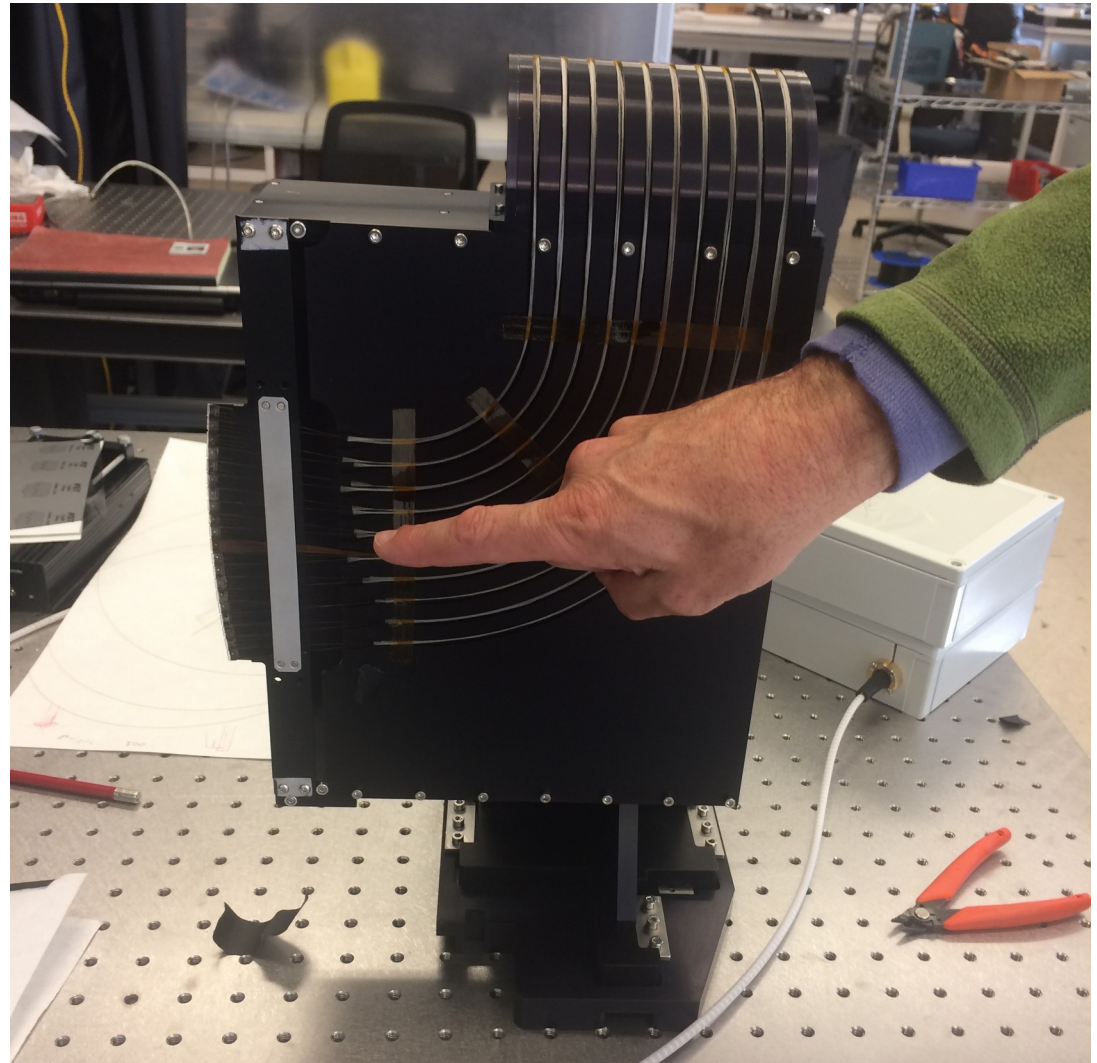



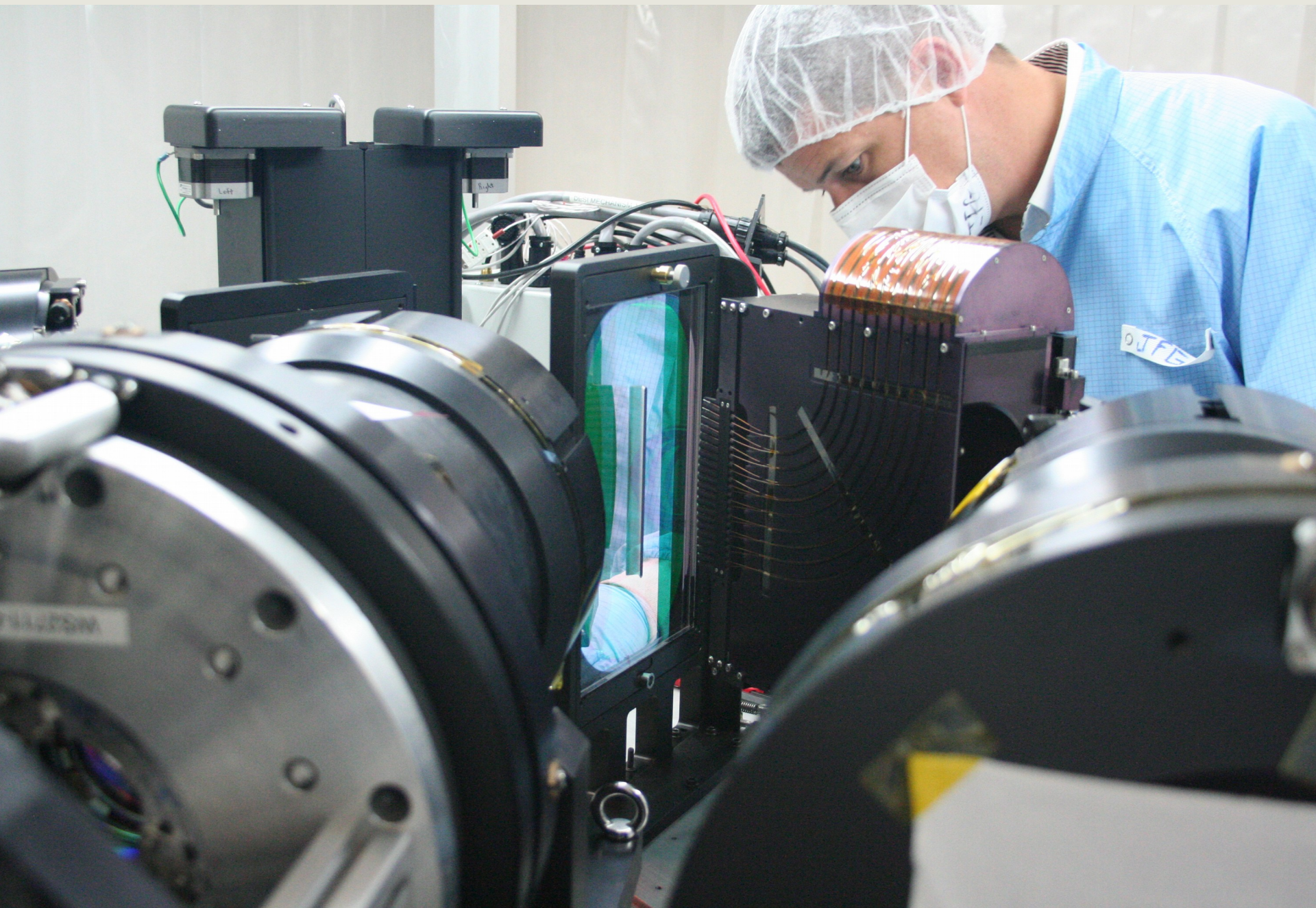

**Dark Energy Spectroscopic Instrument**

# Throughput measurement principles

- **Motivation** : for many previous spectrograph projects, effective transmission **much lower than predicted** from optical models. **Huge risk**, may **endanger the DESI science**.
- Principle : Measurement to be done during **slit removal/reinstall** repeatability test (limited overhead)
- **Calibration of the total flux** at the exit of each fiber of the sparse fiber slit
- **Proposed Procedure** : for the same illumination setups (LEDs)
  - **(1) Sparse Test Slit outside of the spectrograph, in front of our device** : flux (in the same illumination conditions) measured by our calibrated photodiode, for each LED / fiber ;
  - **(2) Sparse Test Slit inside the spectrograph** : integrated flux measured on the CCD for the 3 arms of the spectrograph for each LED / fiber ;
  - **Ratio (2)/(1)** gives **throughput** (from fiber exit to the CCD included)





# Talk outline

- Introduction: the DESI project
- eBOSS/DESI Team at LPNHE
- Throughput Measurement: Principles
- **Flux Calibration Device for the Test Fiber Slit**
- Measurement Campaigns
- Data Analysis
- Focal Ratio Degradation (FRD) estimate (on going)
- Results, Conclusions and Perspectives





# Collecting light from the fibers: mechanical design

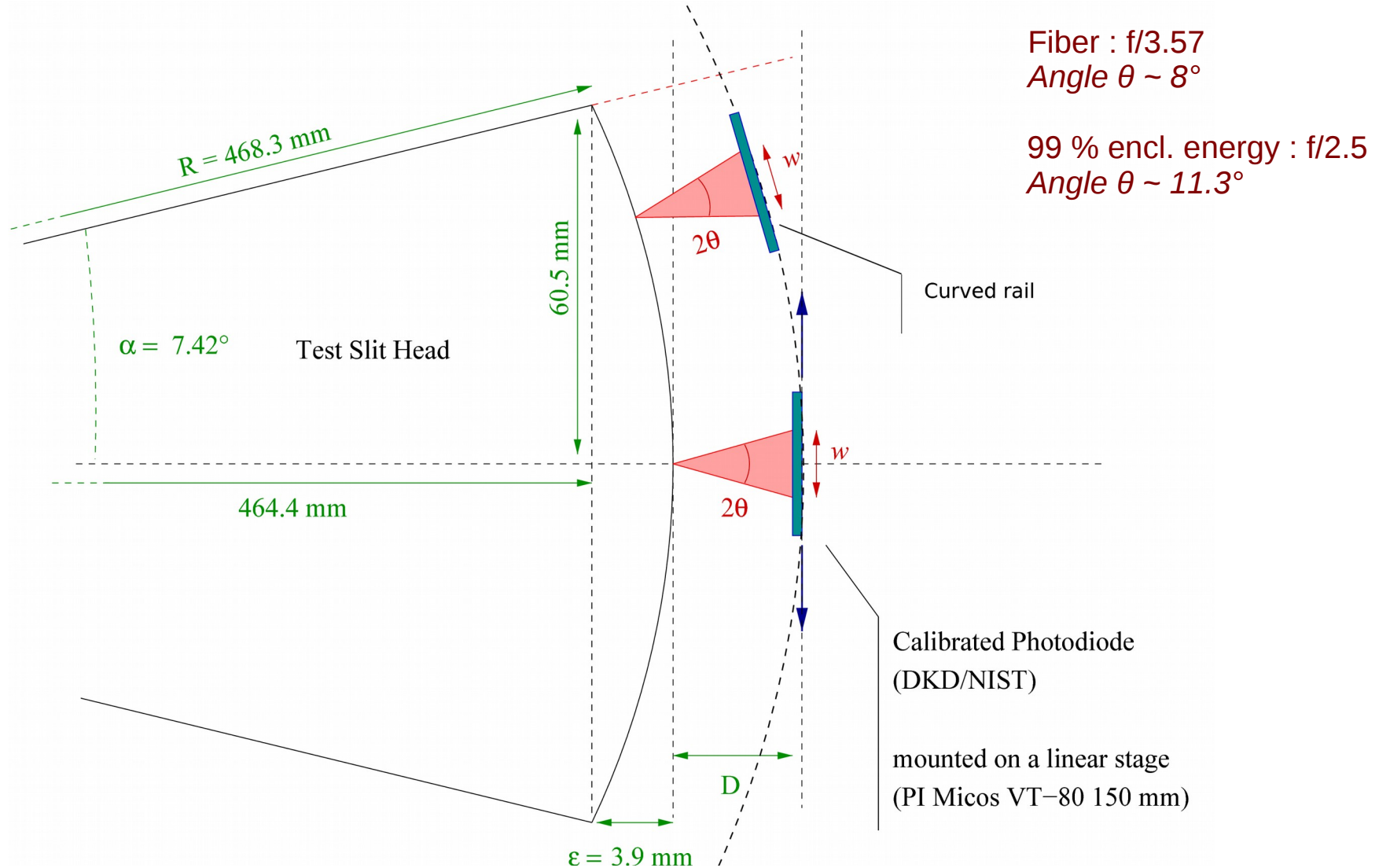

# Throughput measurement device

Motorized  
linear stage  
Pi/MICOS  
<0.4  $\mu\text{m}$  accuracy

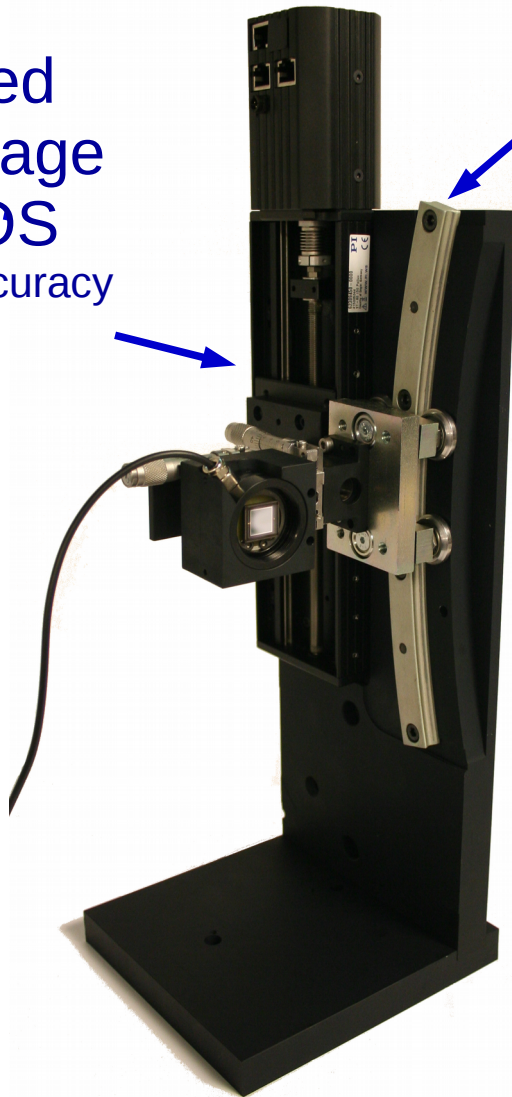

Curved rail  
(radius 500 mm)

Calibrated  
Photodiode  
10x10 mm<sup>2</sup>

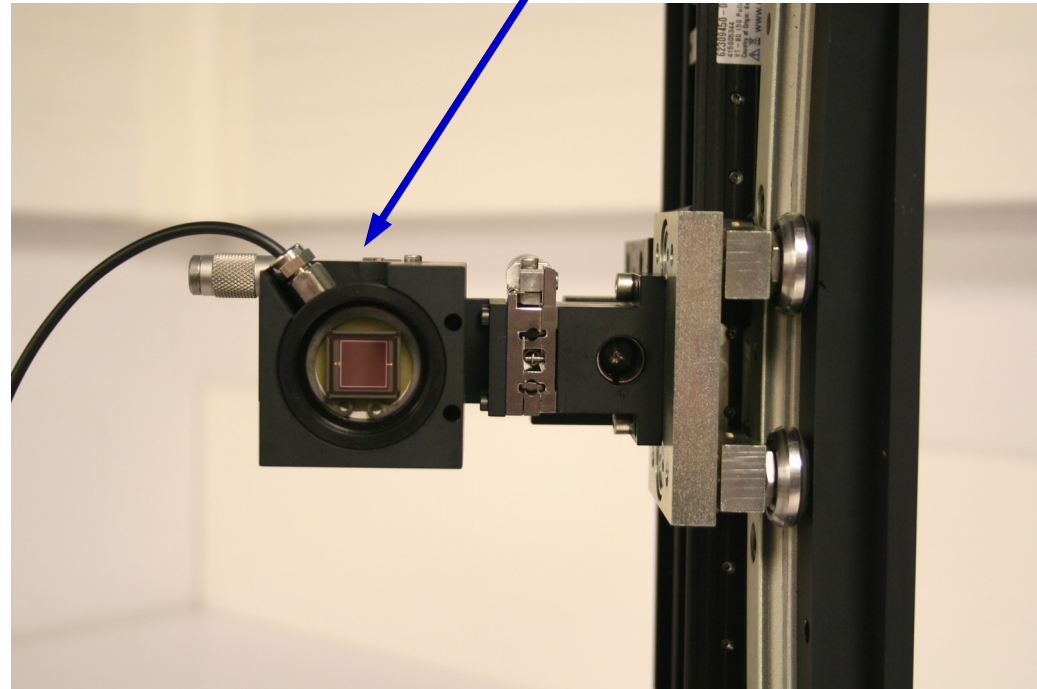

*(vidéo)*



# Throughput measurement device

Dedicated  
Dark Box

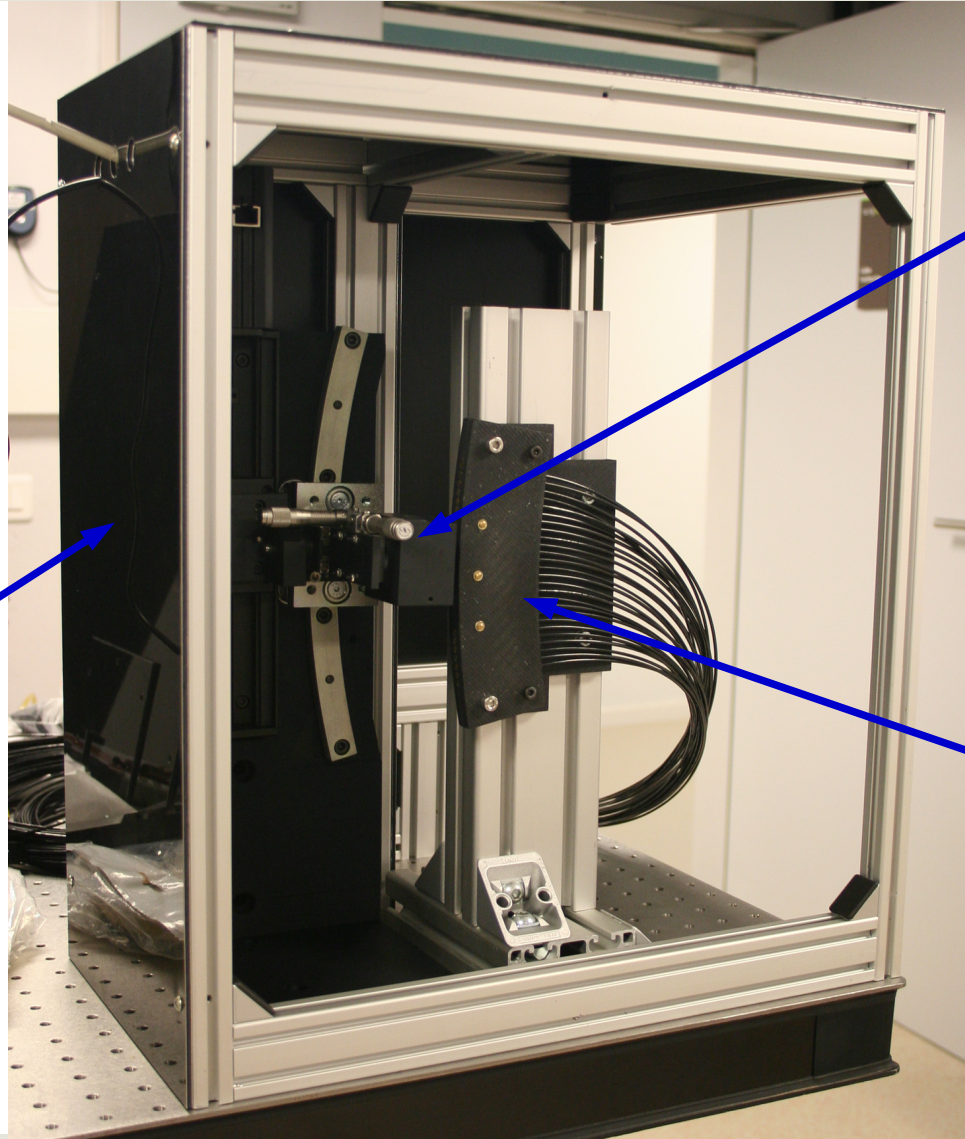

Calibrated  
Photodiode

Mock test slit  
3D printed  
Old fiber bundle  
(DESY, H1)





# Mesure du flux : photodiodes calibrées

- MD-37-SU100 **calibrated (spectral responsivity [A/W])**
  - **DKD (DE) certified absolute calibration**
  - 2 % on 250 – 1100 nm.
- Size : 10x10 = 100 mm<sup>2</sup>
- Photodiode current readout : picoammeter  
**Keithley 6514, or 6482 (2 channels), (fA)**
- **Simultaneous monitoring of :**
  - Light flux in the integrating sphere
  - Light flux exiting the fiber→ Control of the **illumination stability**



# Illumination Testbench (AMU)

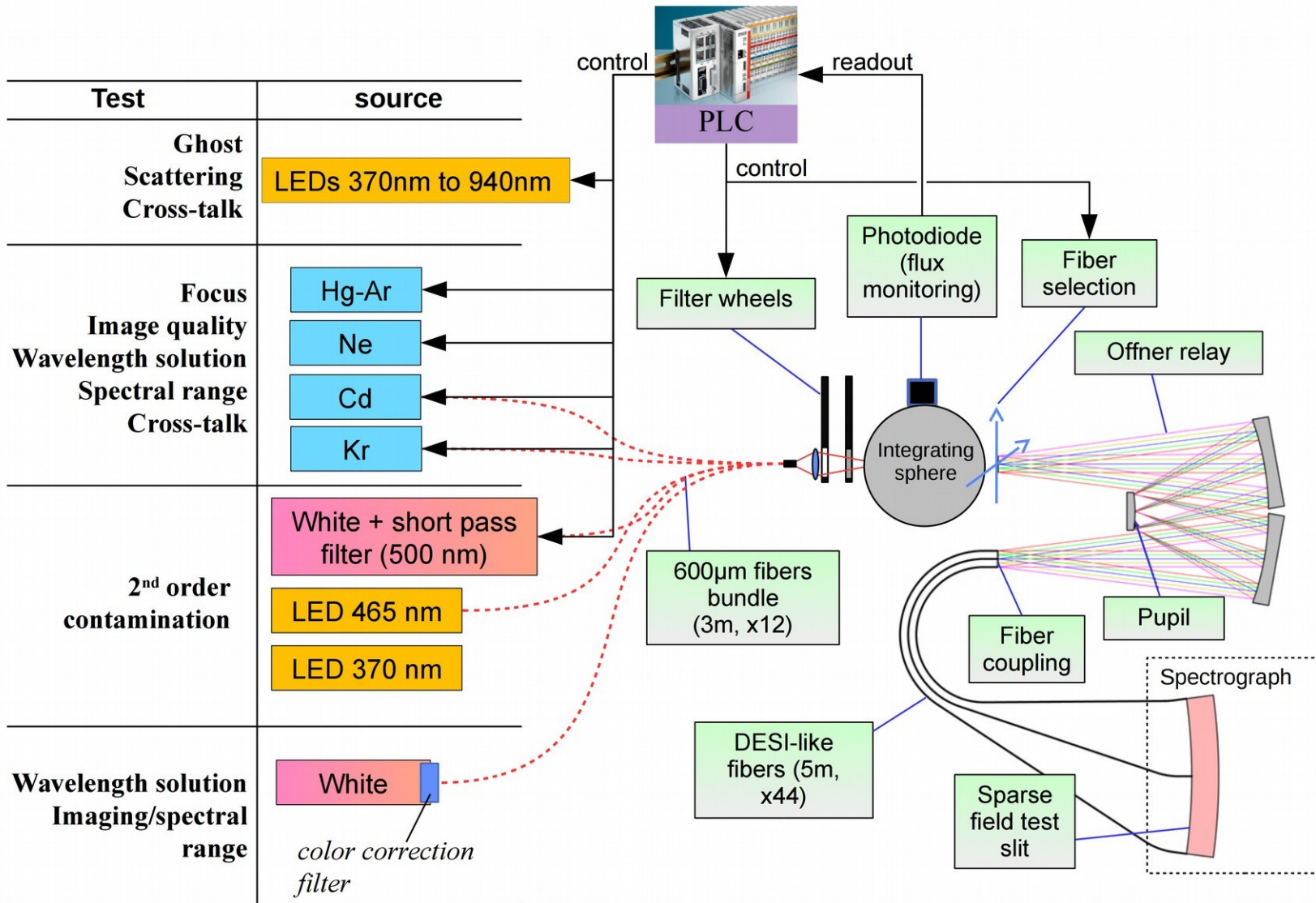

# Illumination Testbench (AMU)

**LED : bright enough**  
**Compact spectrum !**

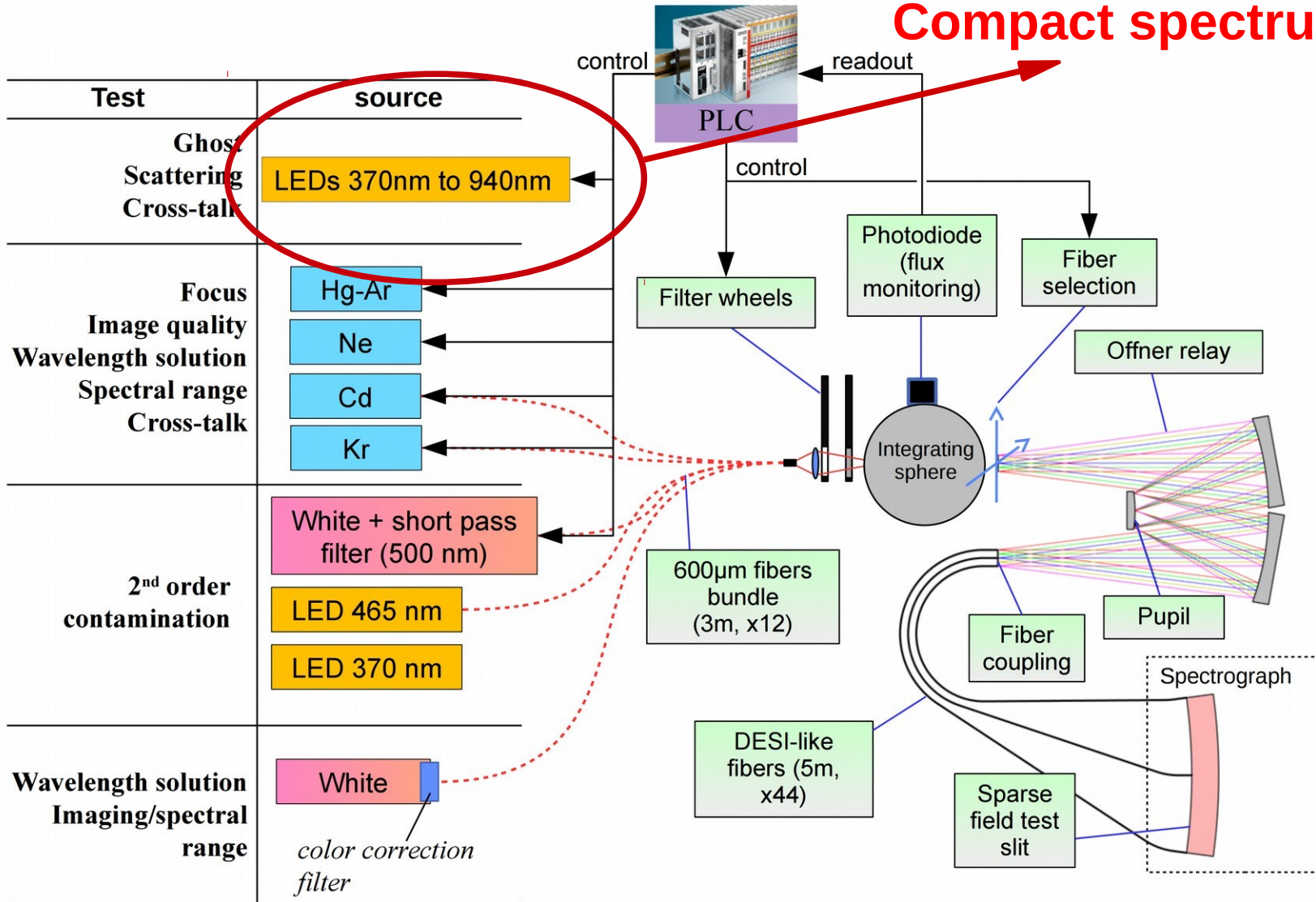



# LED spectra: compact spectra

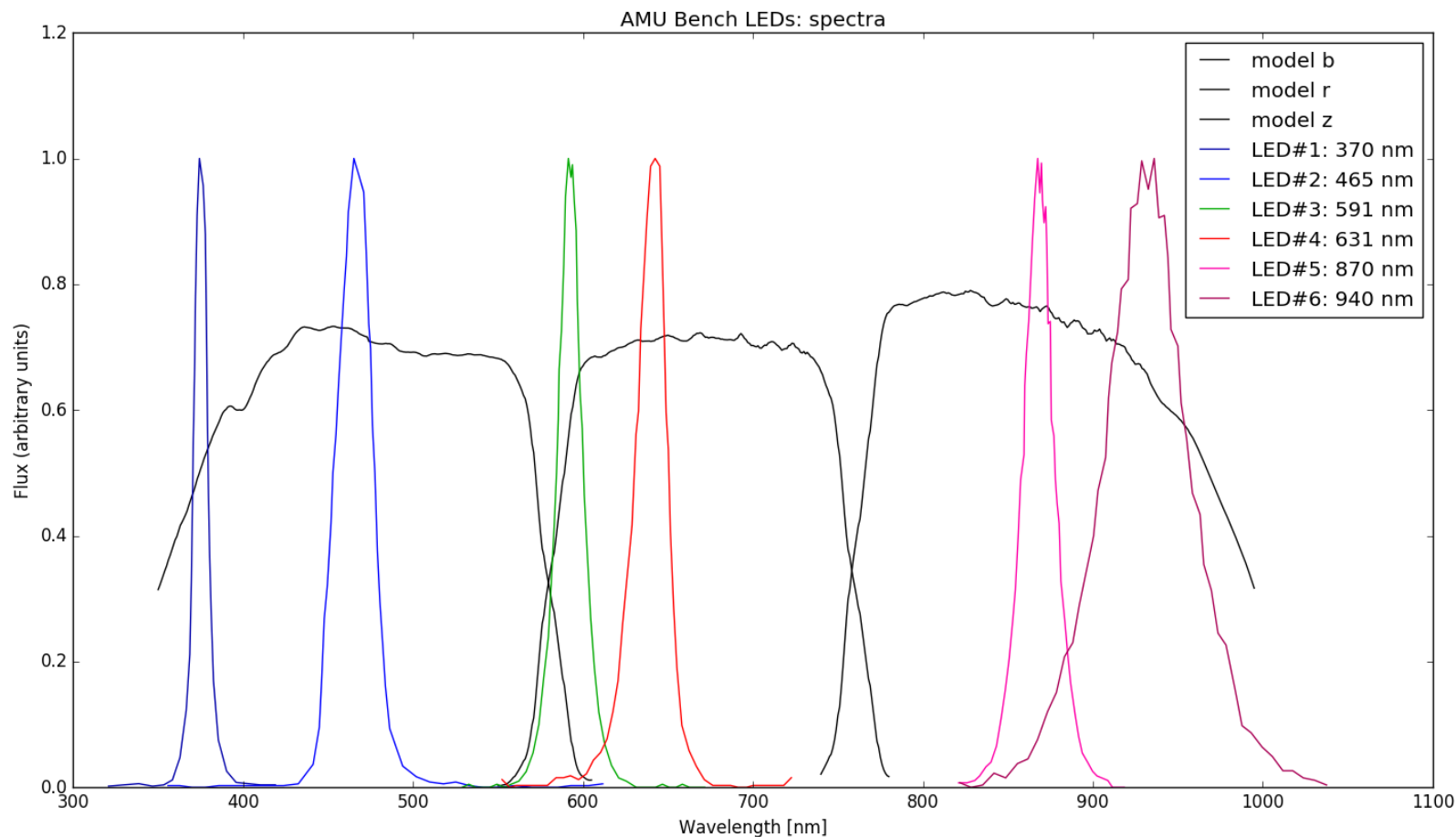

# Photodiode Calibration (DKD certified)

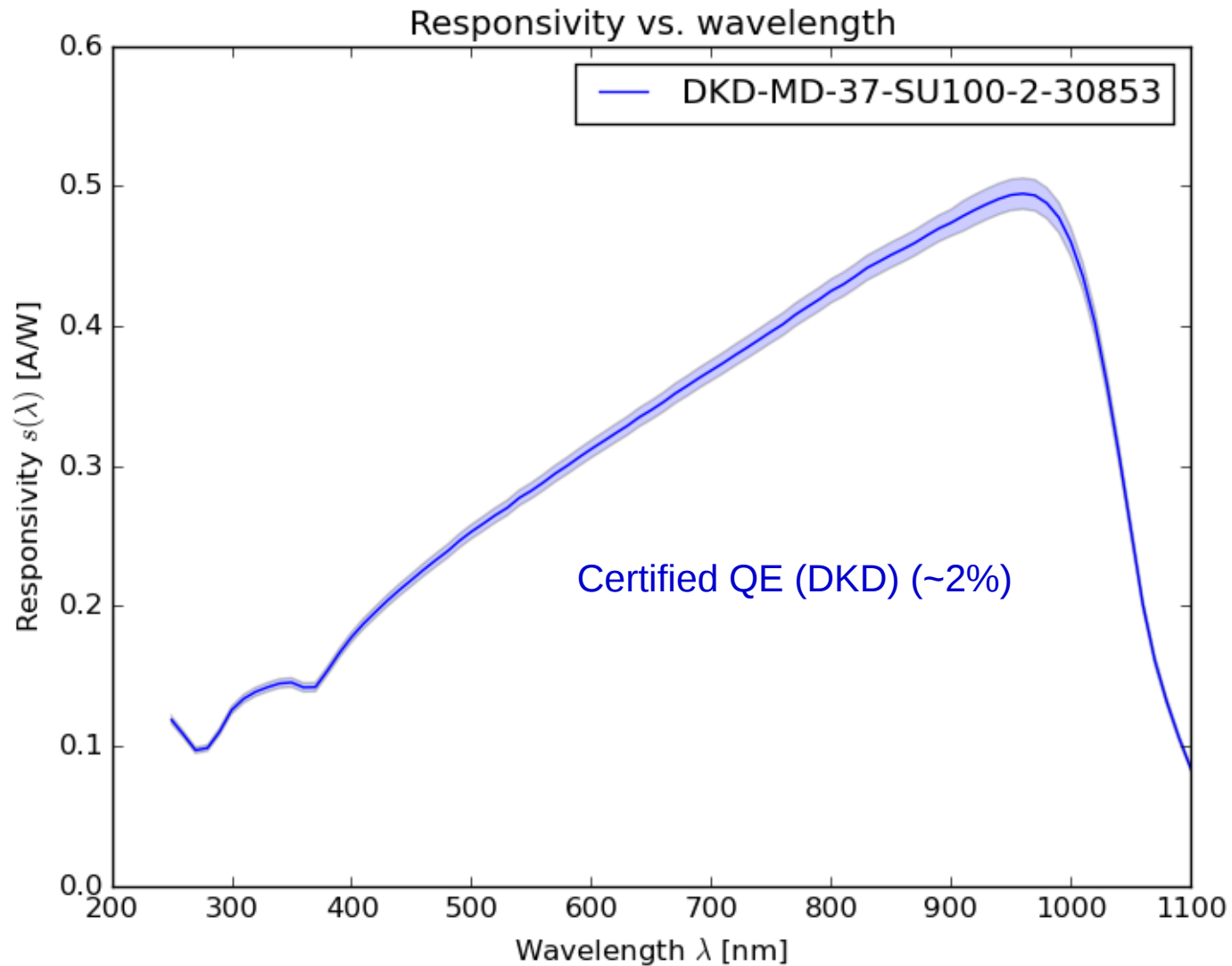

# Photodiode Calibration (DKD certified)

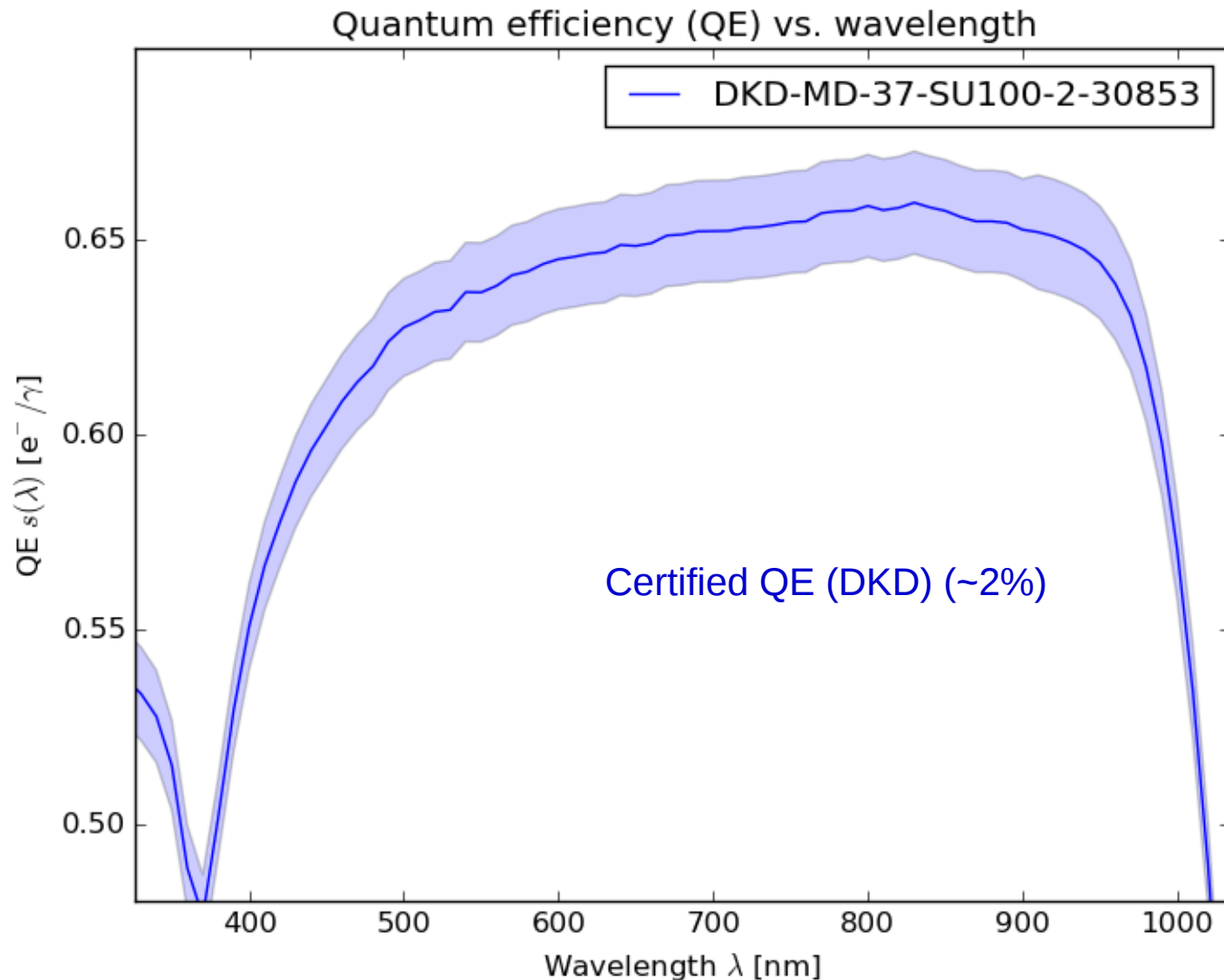

# Intercalib. : banc spectro-photométrique DICE

DICE 24-LED ultra stable source,  
attached on a XY motorized stage.

Czerny-Turner monochromator  
with a triple grating turret.

Plateform fixed on a XYZ motorized stage  
Several photodiodes and other sensors  
could be attached to this platform.

Z motorized stage (range 1593 mm)

X: [0 : 150 mm]

Y: [0 : 150 mm]

X: [0 : 300 mm]

Z: [-1593 : 0 mm]

Y: [0 : 300 mm]

NIST  
(0.2%)

DKD

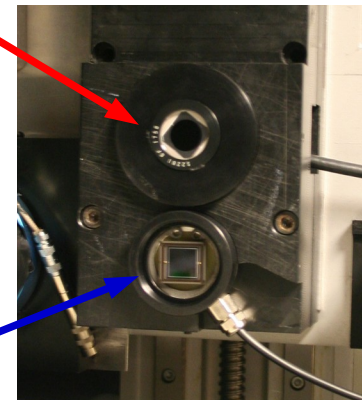

Dark Energy Spectroscopic Instrument

Laurent Le Guillou (UPMC/LPNHE)  
LPNHE, Réunion du Vendredi, Paris, 2017-09-08

32 / 91



# Photodiode Calibration & checks at LPNHE

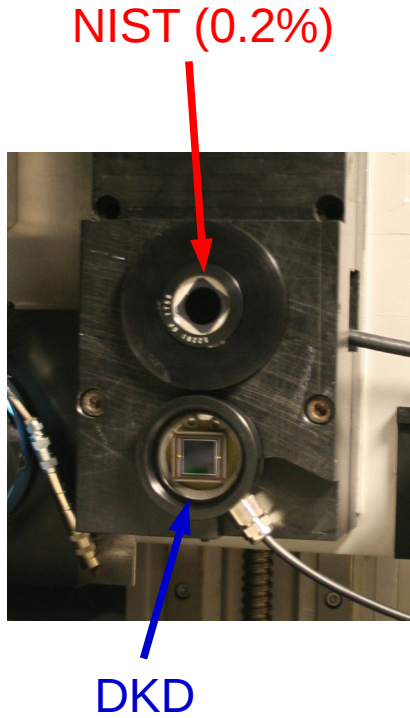

See DESI-2635 (LLG)

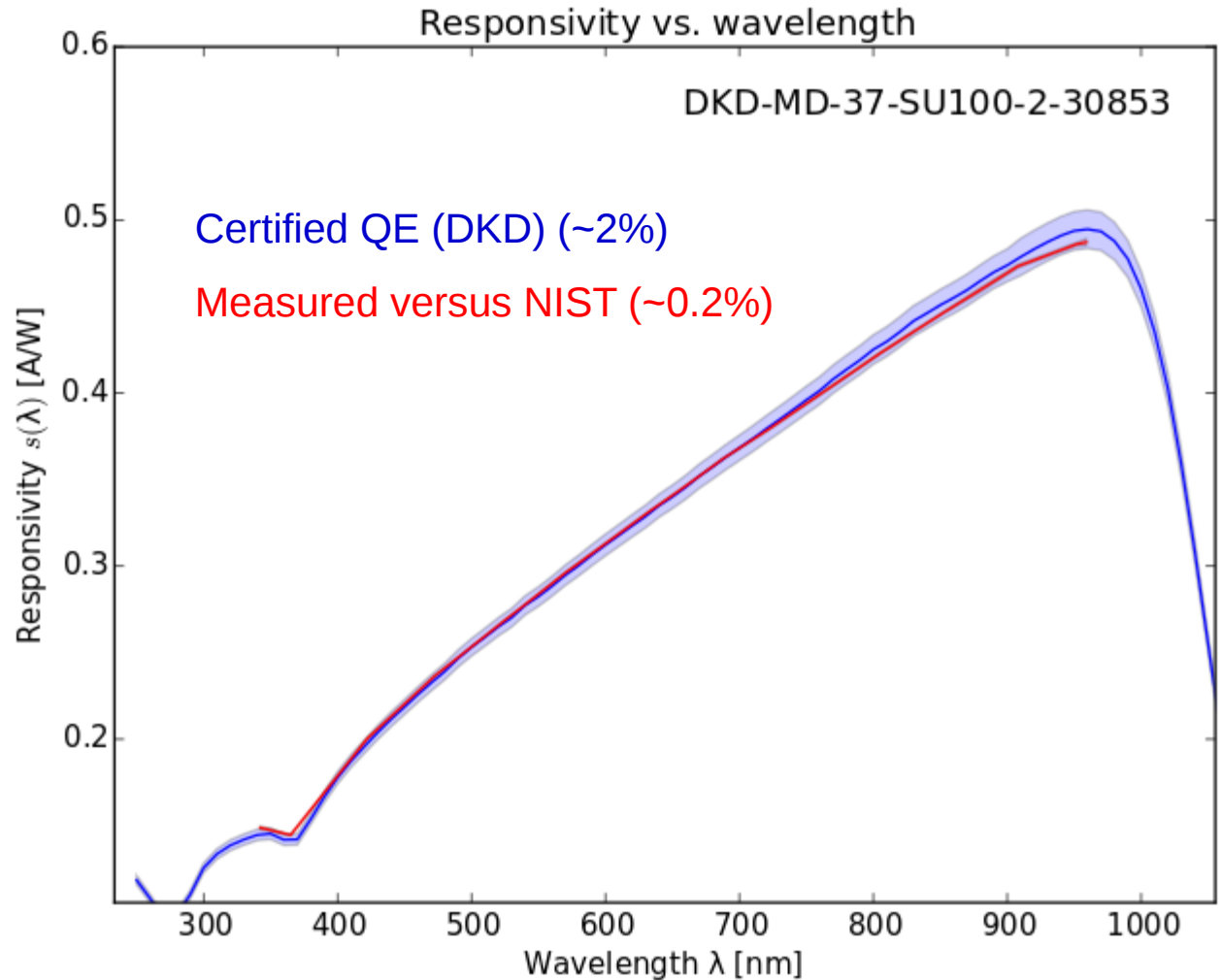

# Photodiode Calibration & checks at LPNHE

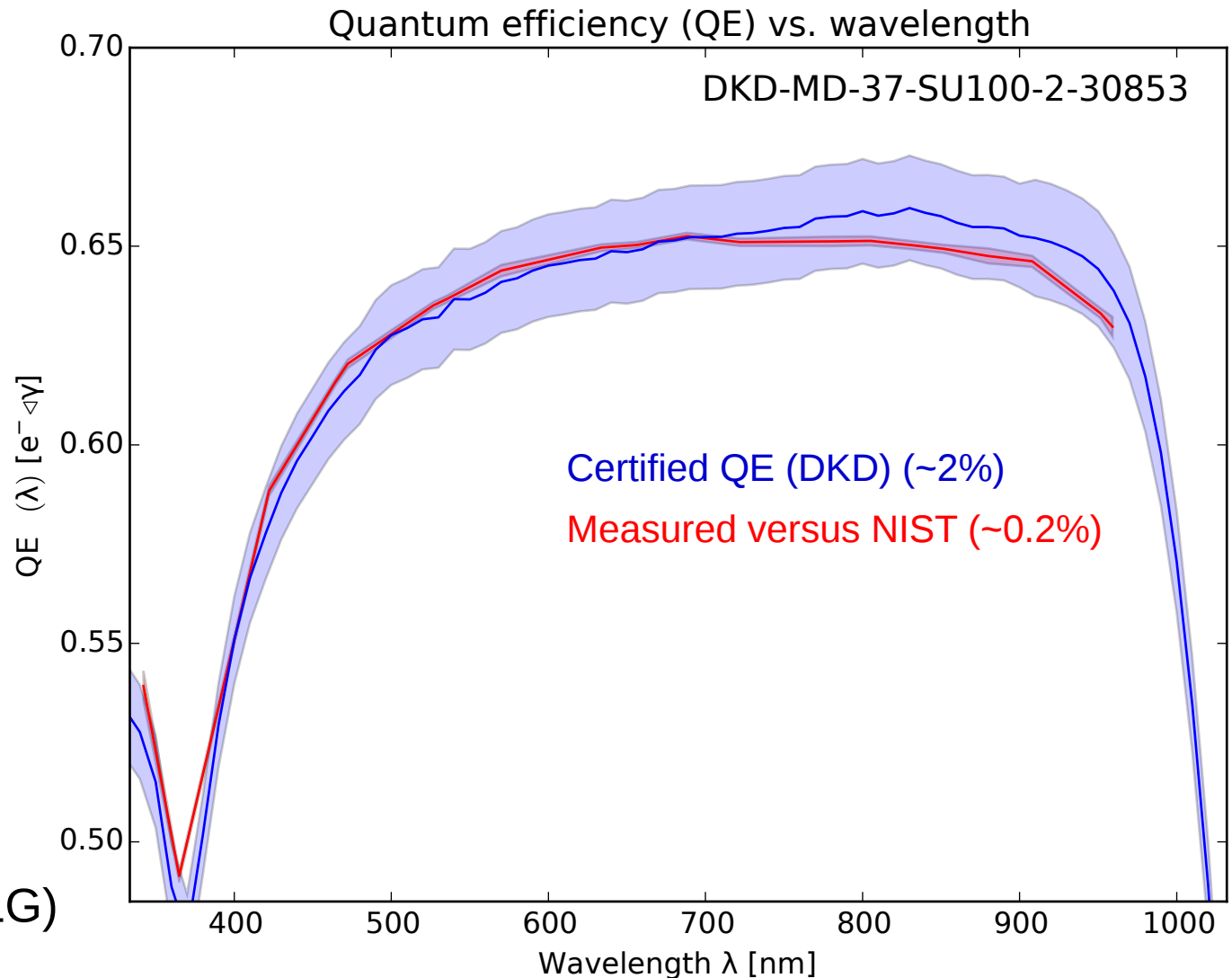
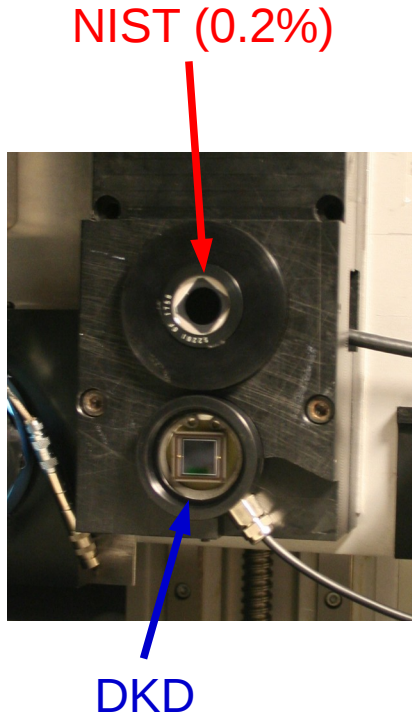

See DESI-2635 (LLG)



Dark Energy Spectroscopic Instrument

Laurent Le Guillou (UPMC/LPNHE)  
LPNHE, Réunion du Vendredi, Paris, 2017-09-08

34 / 91

# Integration on the AMU Testbench

- **Challenging mechanical interface** between the fiber slit and our device (collision with fiber ends should be avoided at all cost!!)
- **Integration within the AMU testbench software** and the ICS (Xavier Regal, AMU)

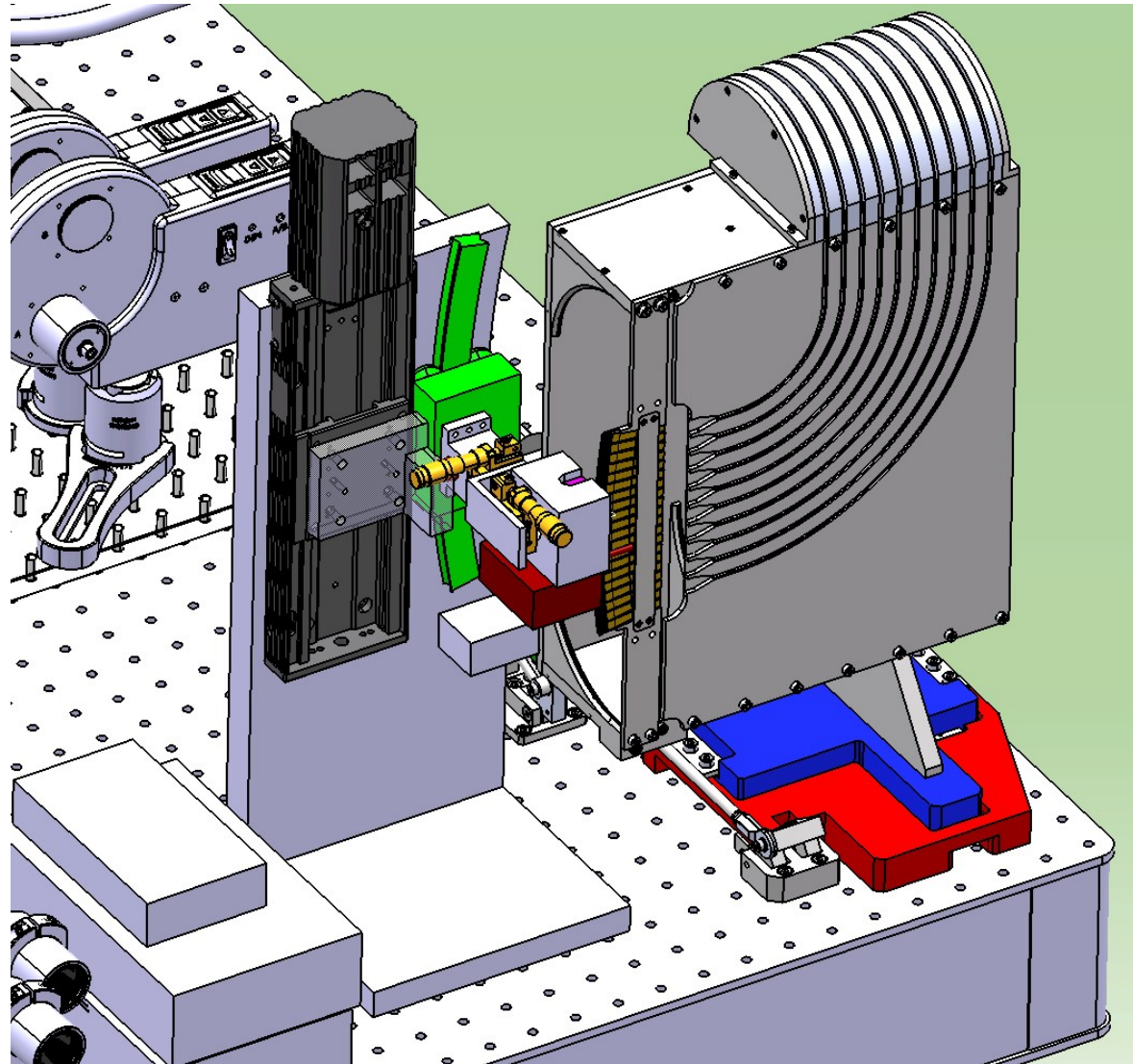



# Integration on the AMU Testbench (dark box)

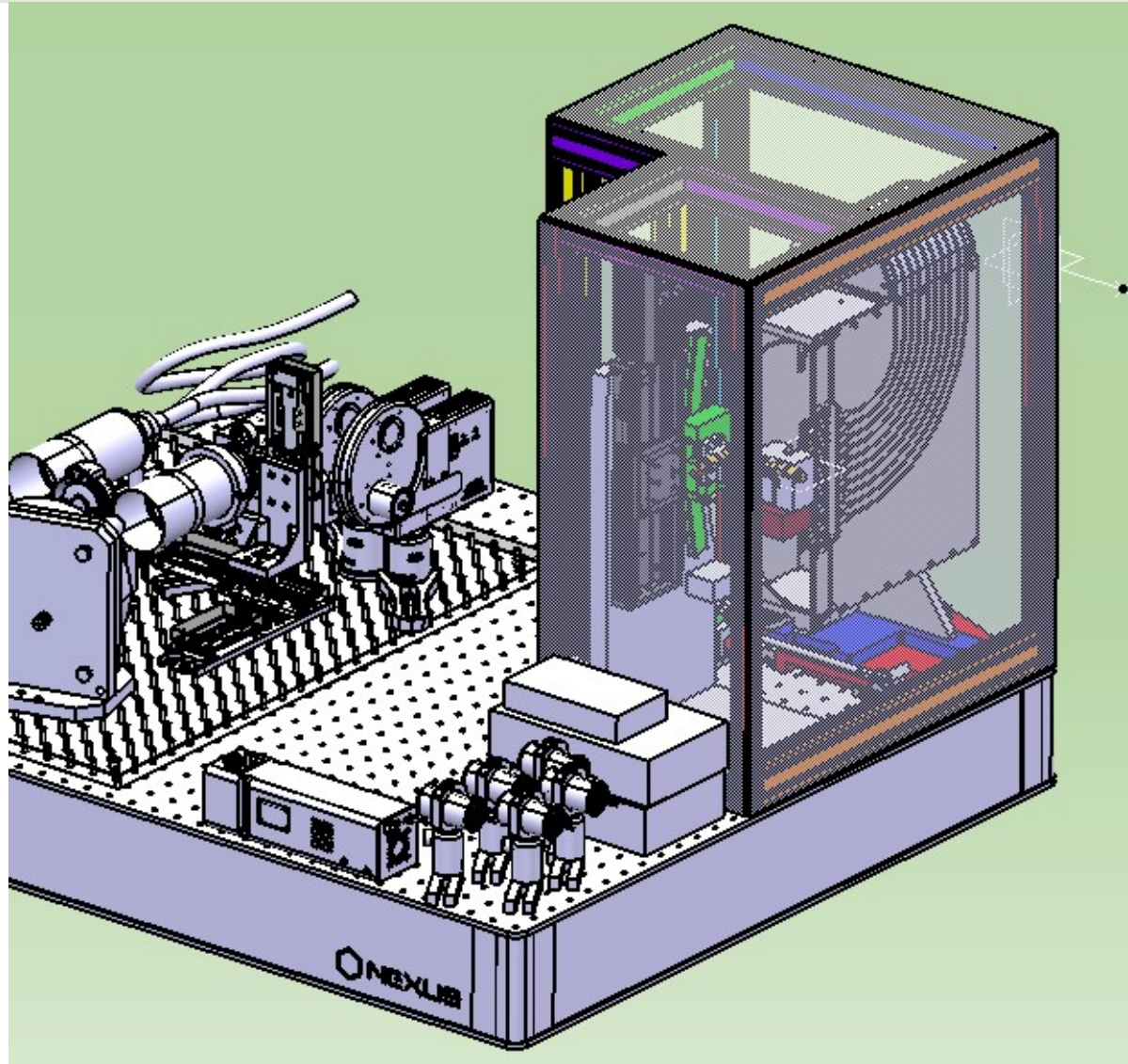



# Installation at Winlight (sept. 2016)

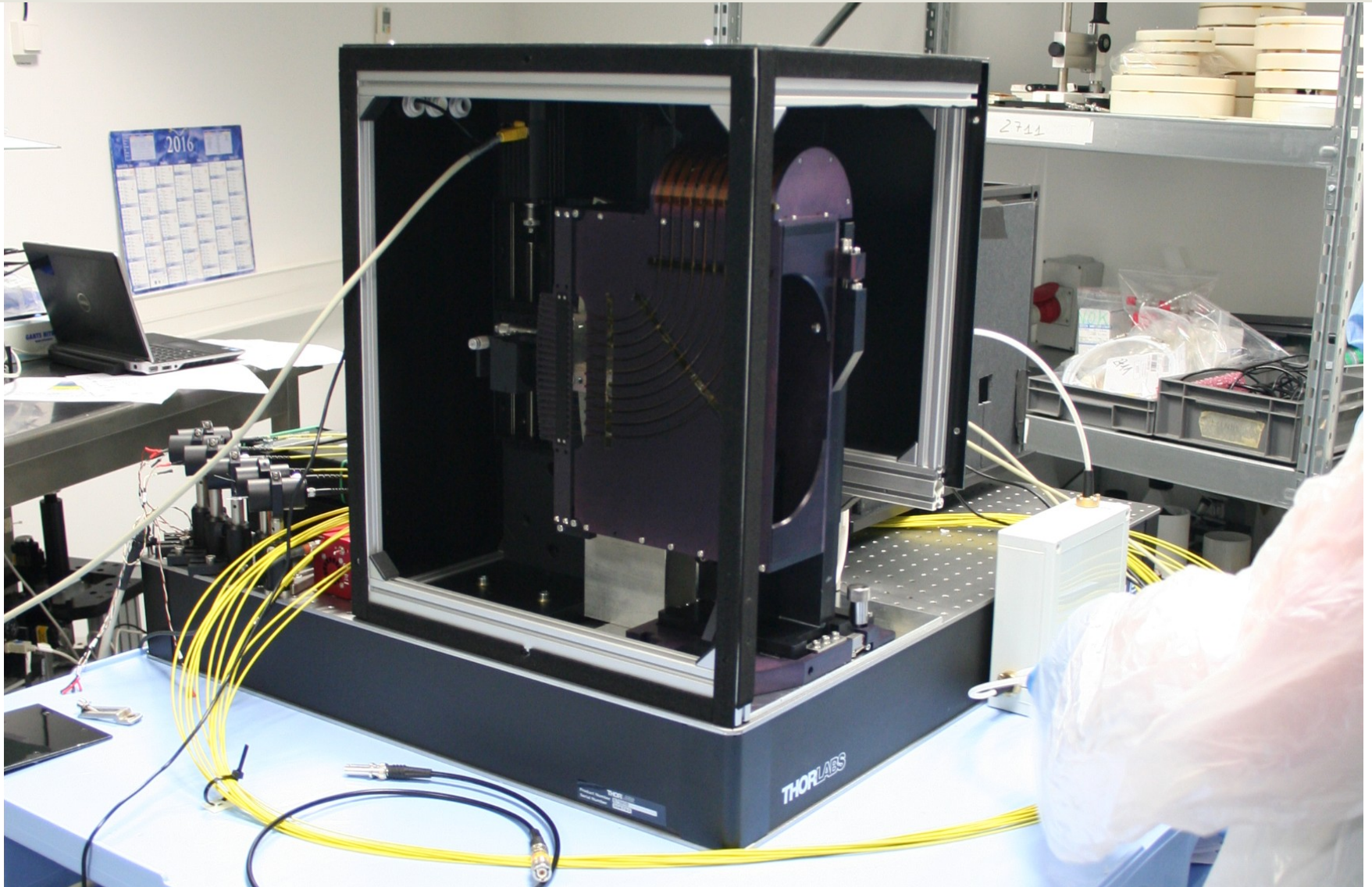

**Dark Energy Spectroscopic Instrument**

Laurent Le Guillou (UPMC/LPNHE)  
LPNHE, Réunion du Vendredi, Paris, 2017-09-08



# Installation at Winlight (sept. 2016)

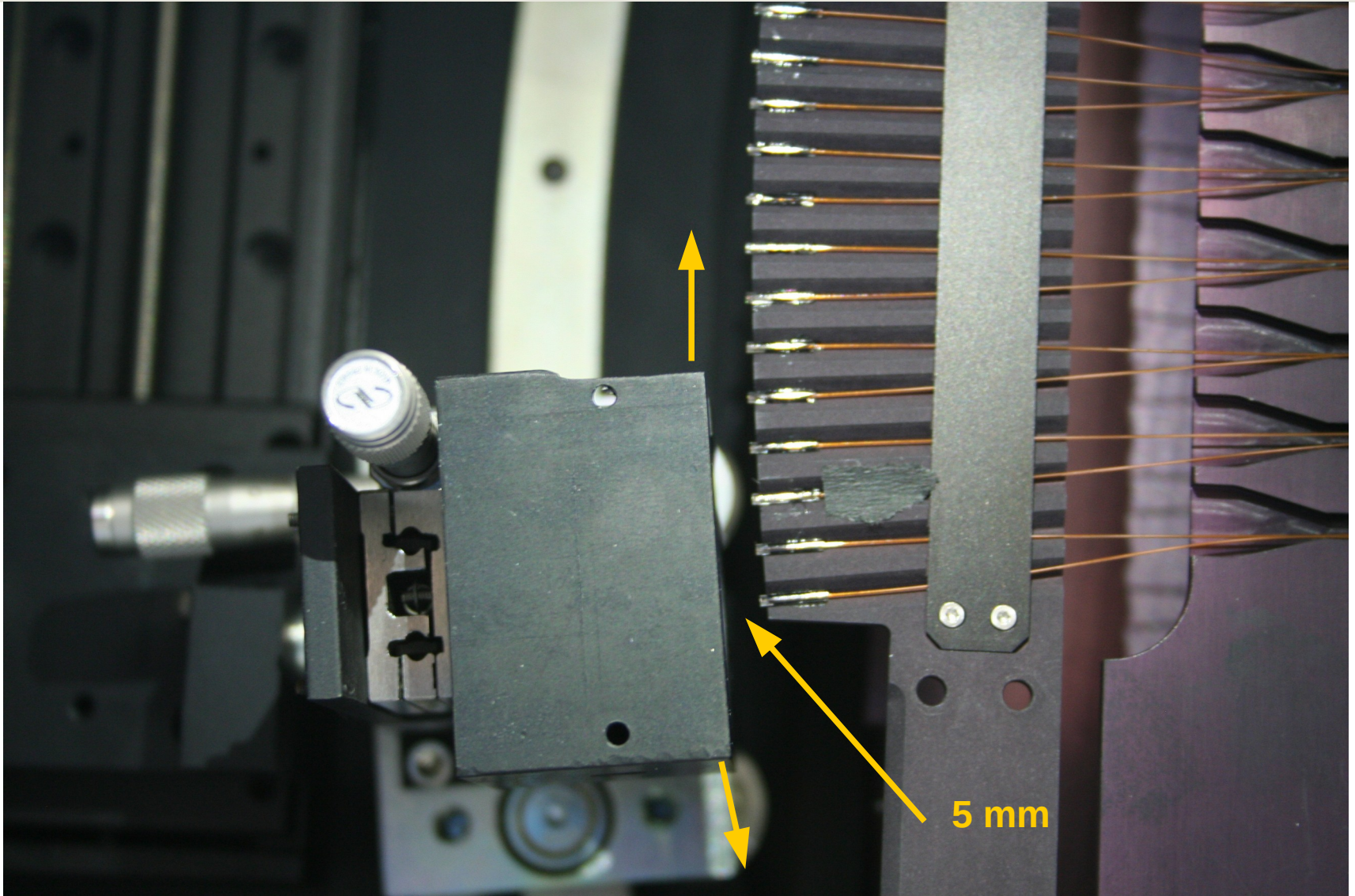



# Installation at Winlight (sept. 2016)

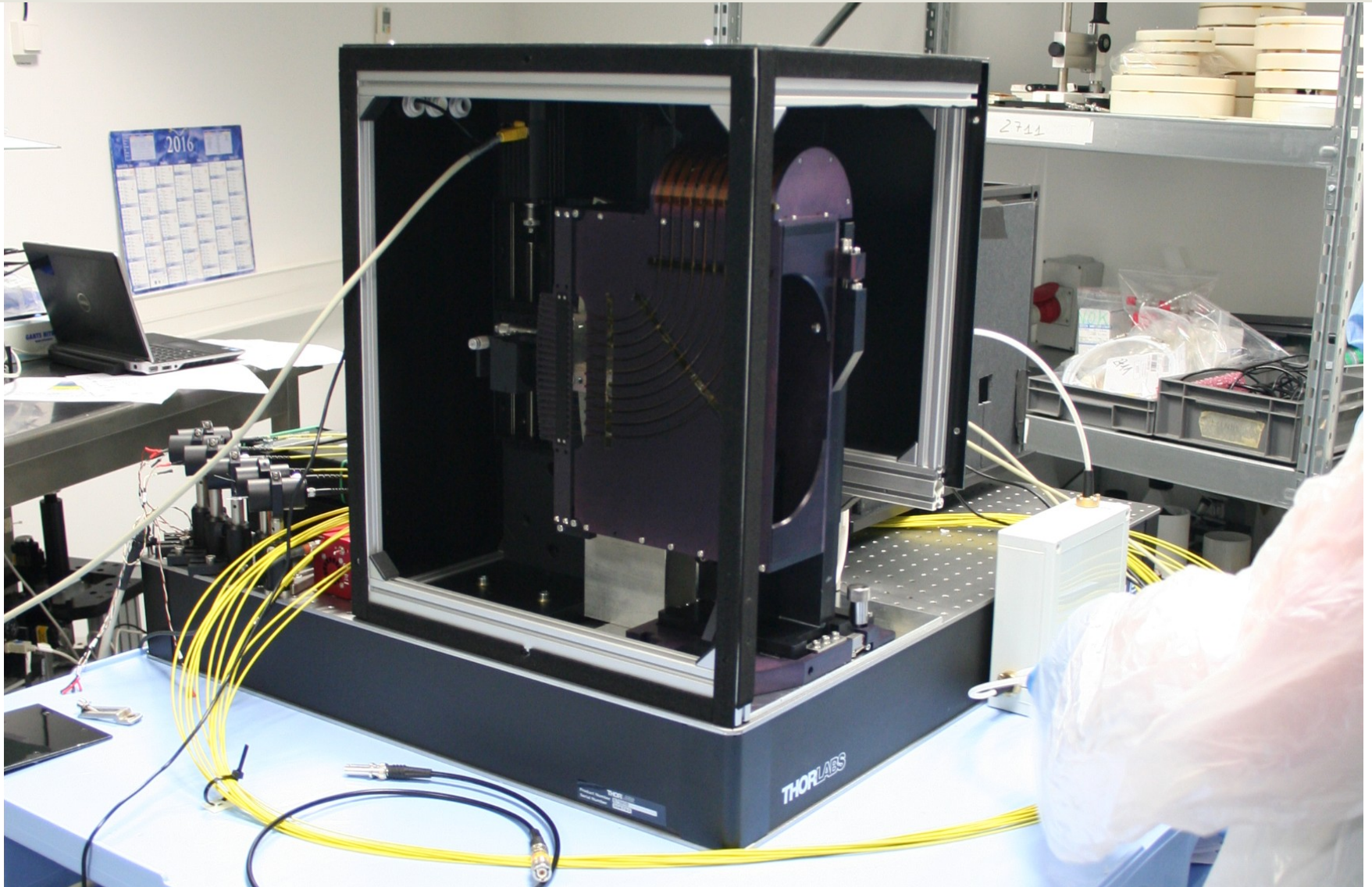

**Dark Energy Spectroscopic Instrument**

Laurent Le Guillou (UPMC/LPNHE)  
LPNHE, Réunion du Vendredi, Paris, 2017-09-08

# Scan of the fiber beam by moving the photodiode

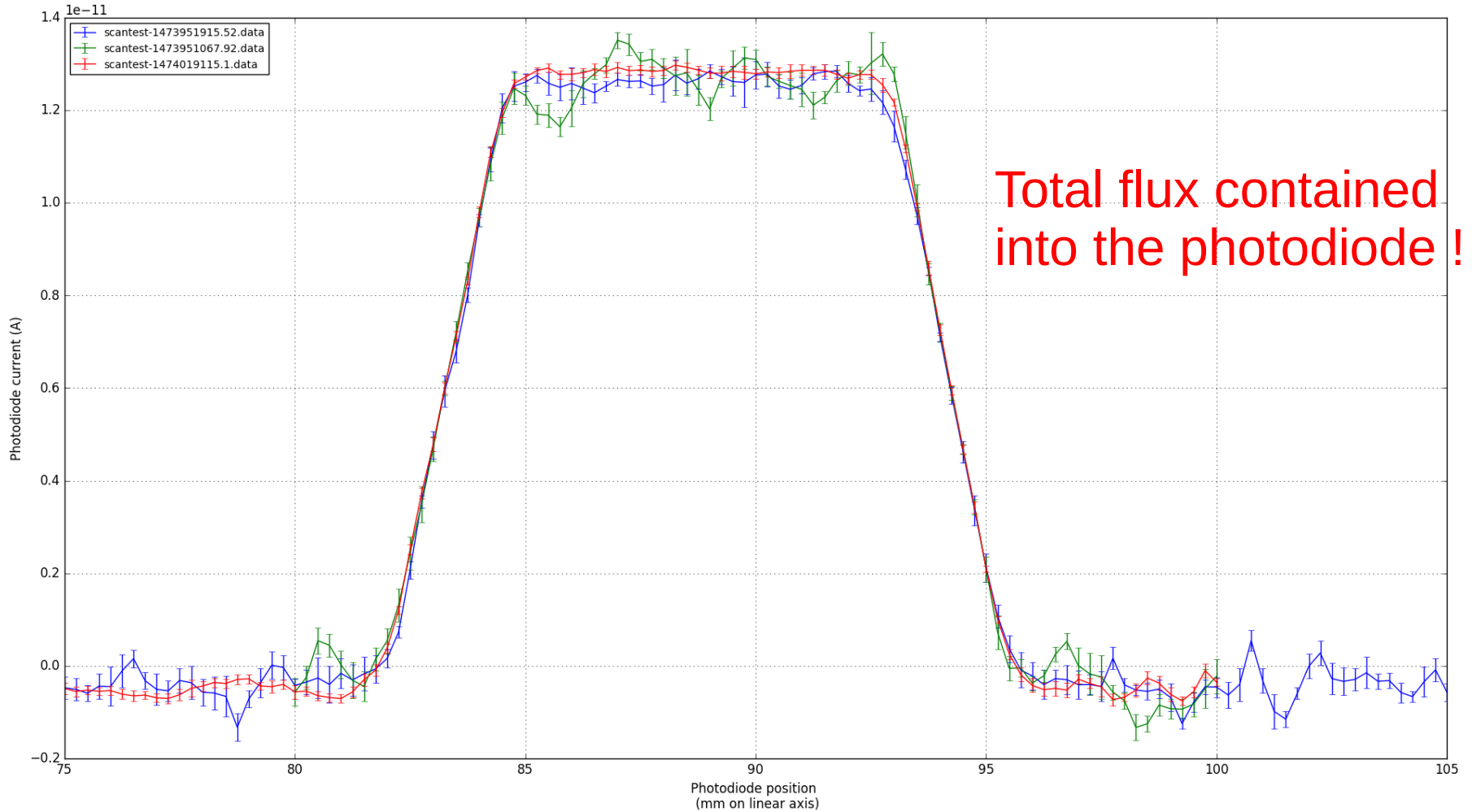

# Measurements campaigns (2017)

- **1<sup>st</sup> campaign: Jan 31 to Feb 2, 2017 (LLG, JG, PEB, SR)**
  - **Absolute flux measurements** (slit in the box)
  - **Separate spectra of all LEDs / individual fibers** (slit in spectro)
  - Scanning the fiber beam with the entire 10x10 photodiode
  - CCD frames to estimate **true shutter time** (W)
  - CCD frames to estimate **the amplifier gains** (W)





# Measurements campaigns (2017)

- **2<sup>nd</sup> campaign: March 14 – 17, 2017 (LLG, PEB, SR)**
  - **Absolute flux measurements** (slit in the box)
  - **Separate spectra of all LEDs / individual fibers** (slit in spectro)
  - Scanning the fiber output beam with the entire photodiode
  - **Scanning the fiber output beam with a 100  $\mu\text{m}$  slit** in front of the photodiode (to model the beam and estimate the FRD)
  - CCD frames to estimate **true shutter time** (W)
  - CCD frames to estimate **the amplifier gains** (W)
  - **Flat slit available: flats, for better ampli. gain measurements**
- **3<sup>rd</sup> campaign: July 3 – 5, 2017 (LLG, PEB)**  
(cancelled due to shutter problems)



# Throughput measurement method

- Measurement to be done during **slit removal/reinstall** repeatability test (limited overhead)
- **Calibration of the total flux** at the exit of each fiber of the sparse fiber slit
- **Proposed Procedure** : for the same illumination setups (LEDs)
  - **(1) Sparse Test Slit outside of the spectrograph, in front of our device** : flux (in the same illumination conditions) measured by our calibrated photodiode for each LED / fiber ;
  - **(2) Sparse Test Slit inside the spectrograph** : integrated flux measured on the CCD for the 3 arms of the spectrograph for each LED / fiber ;
  - **Ratio (2)/(1)** gives **throughput** (from fiber exit to the CCD included)



# Scan of all the sparse slit fibers (centering)

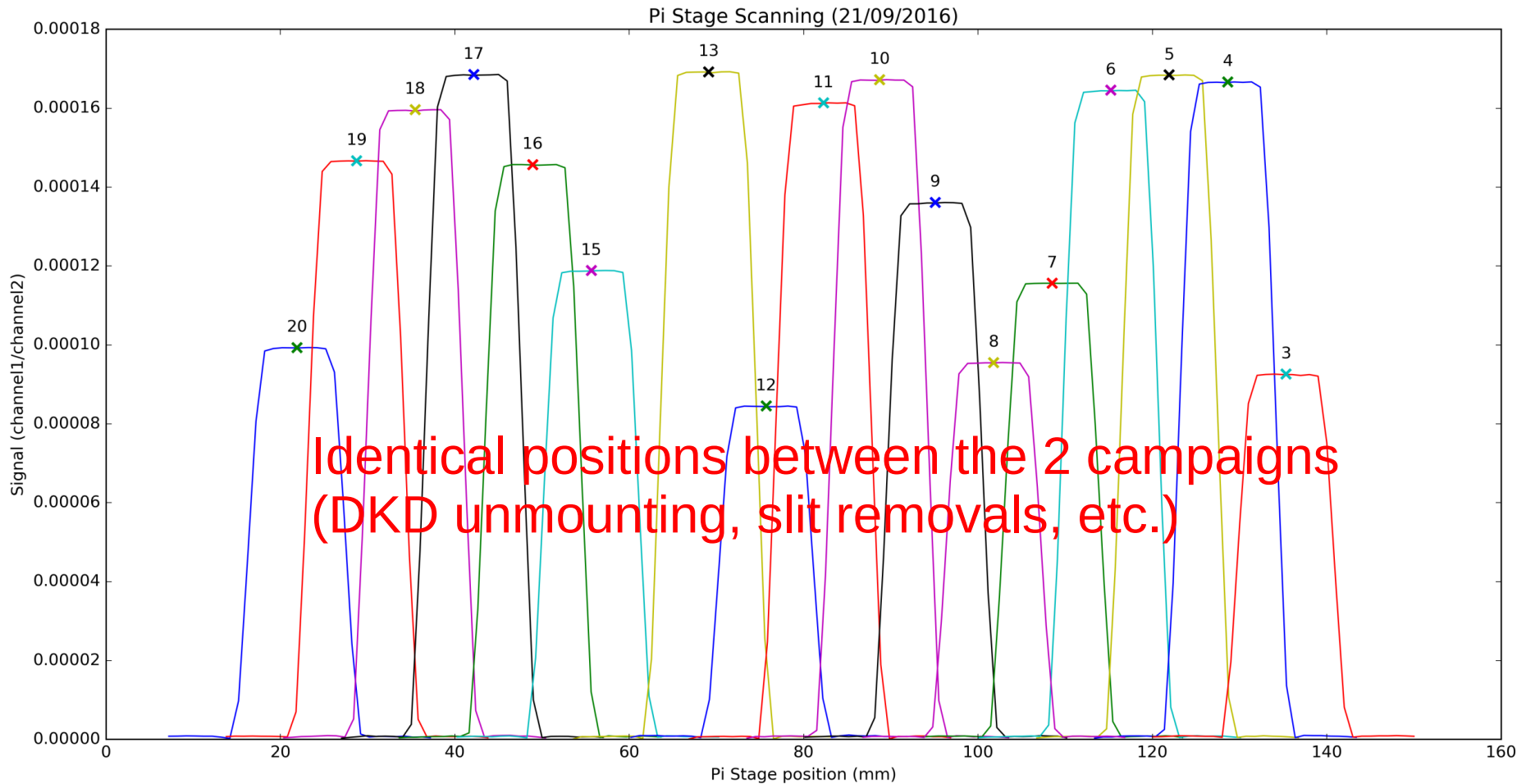

1 broken fiber; last one unreachable (mechanical limit)





# Absolute flux measurements (DKD photocurrent)

- **For each fiber, for each LED :**
  - centering the DK photodiode to catch the whole beam
  - measuring the photocurrent
- **Cycling over OPEN, DARK, and other neutral densities filters**
- **Subtracting dark current**
- **Photocurrents RMS < 0.01 pA**

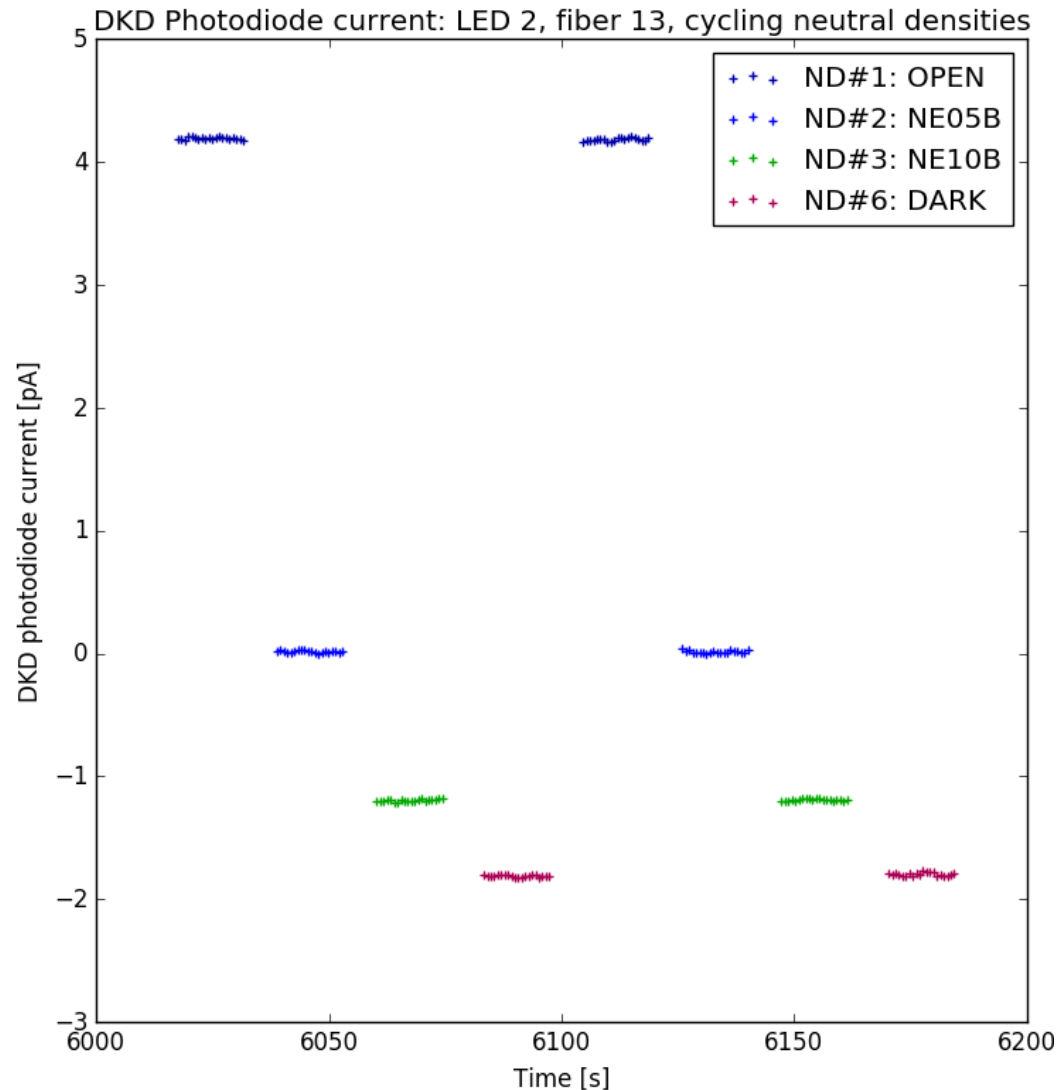
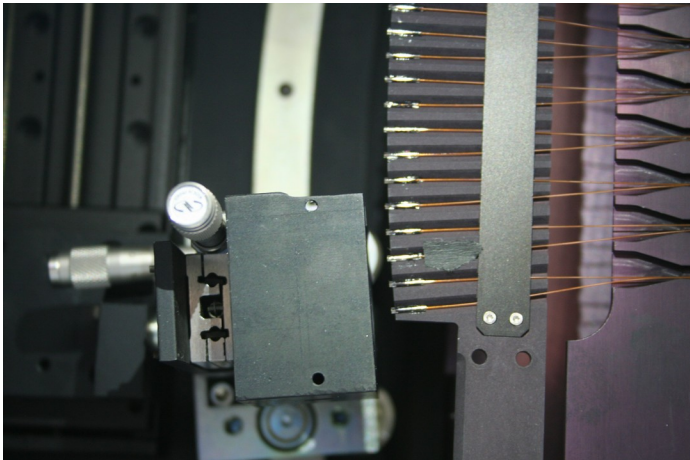

# DKD photocurrents analysis

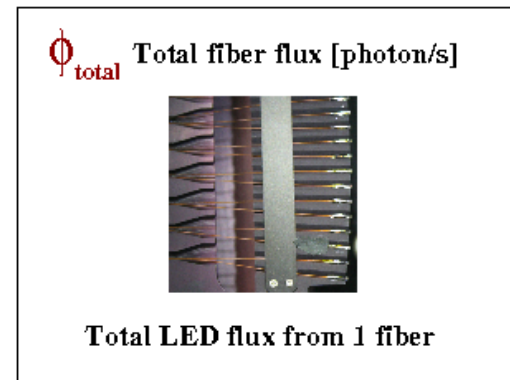
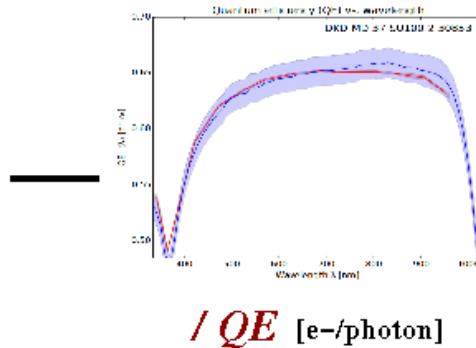
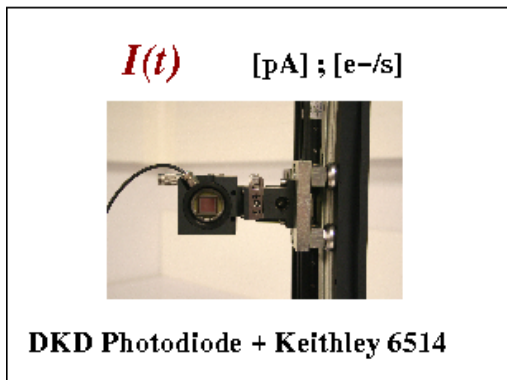

$$\phi_{injected} = \frac{I - I_{dark}}{QE_{DKD, LED}} \times FRD_{fiber}$$

$$QE_{DKD, LED} = \frac{\int \phi_{LED}(\lambda) QE_{DKD}(\lambda) d\lambda}{\int \phi_{LED}(\lambda) d\lambda}$$

FRD correction

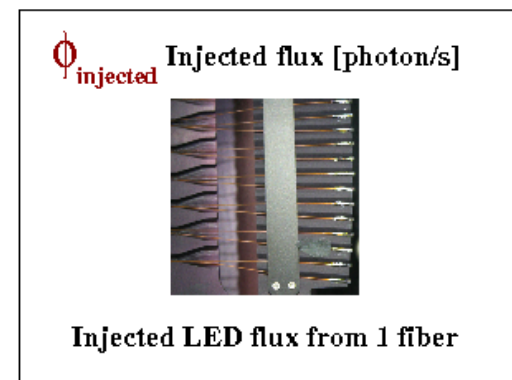

# Throughput measurement method

- Measurement to be done during **slit removal/reinstall** repeatability test (limited overhead)
- **Calibration of the total flux** at the exit of each fiber of the sparse fiber slit
- **Proposed Procedure** : for the same illumination setups (LEDs)
  - **(1) Sparse Test Slit outside of the spectrograph, in front of our device** : flux (in the same illumination conditions) measured by our calibrated photodiode for each LED / fiber ;
  - **(2) Sparse Test Slit inside the spectrograph** : integrated flux measured on the CCD for the 3 arms of the spectrograph for each LED / fiber ;
  - **Ratio (2)/(1)** gives **throughput** (from fiber exit to the CCD included)





# Le spectrographe DESI

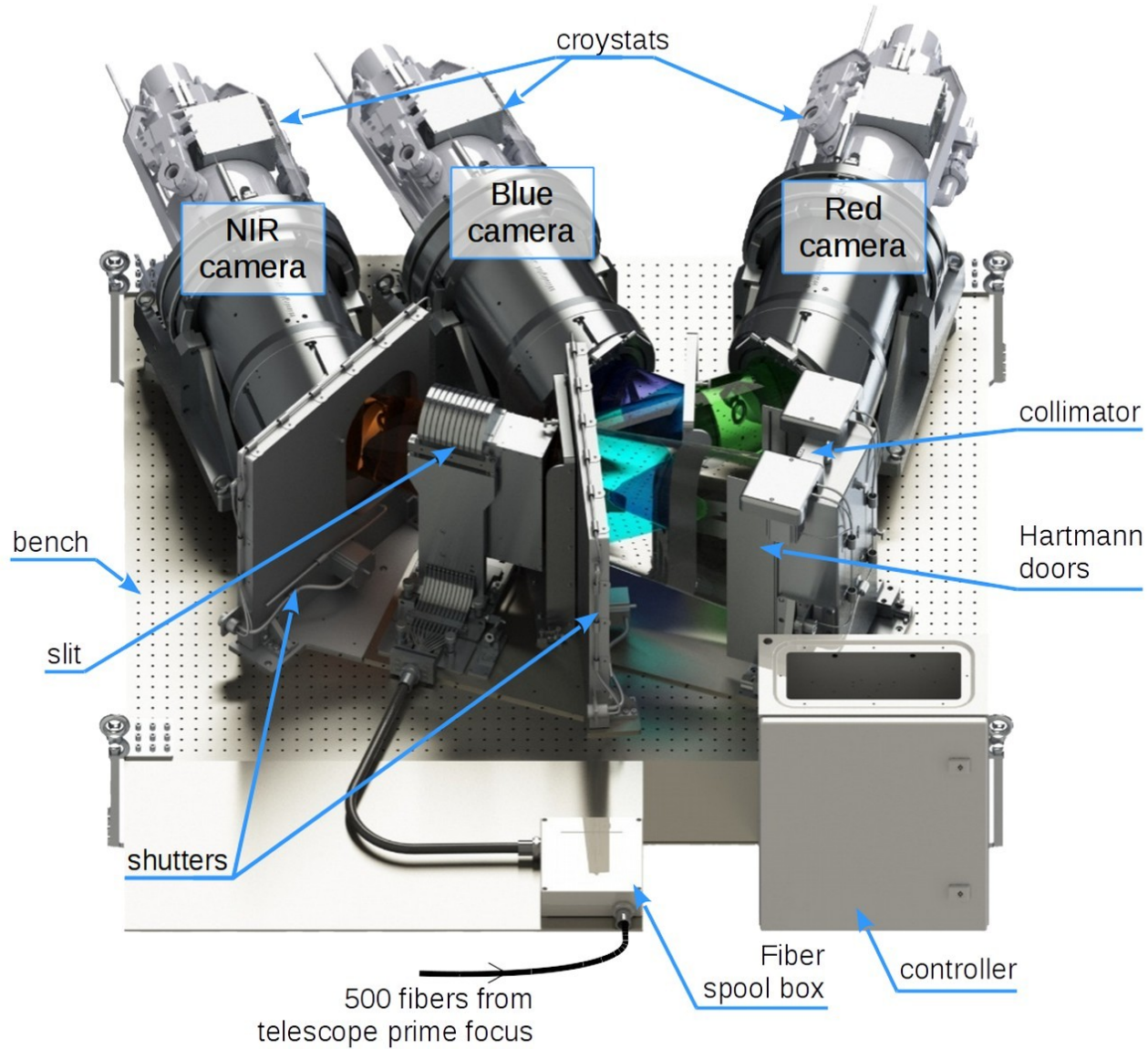

# Le spectrographe DESI

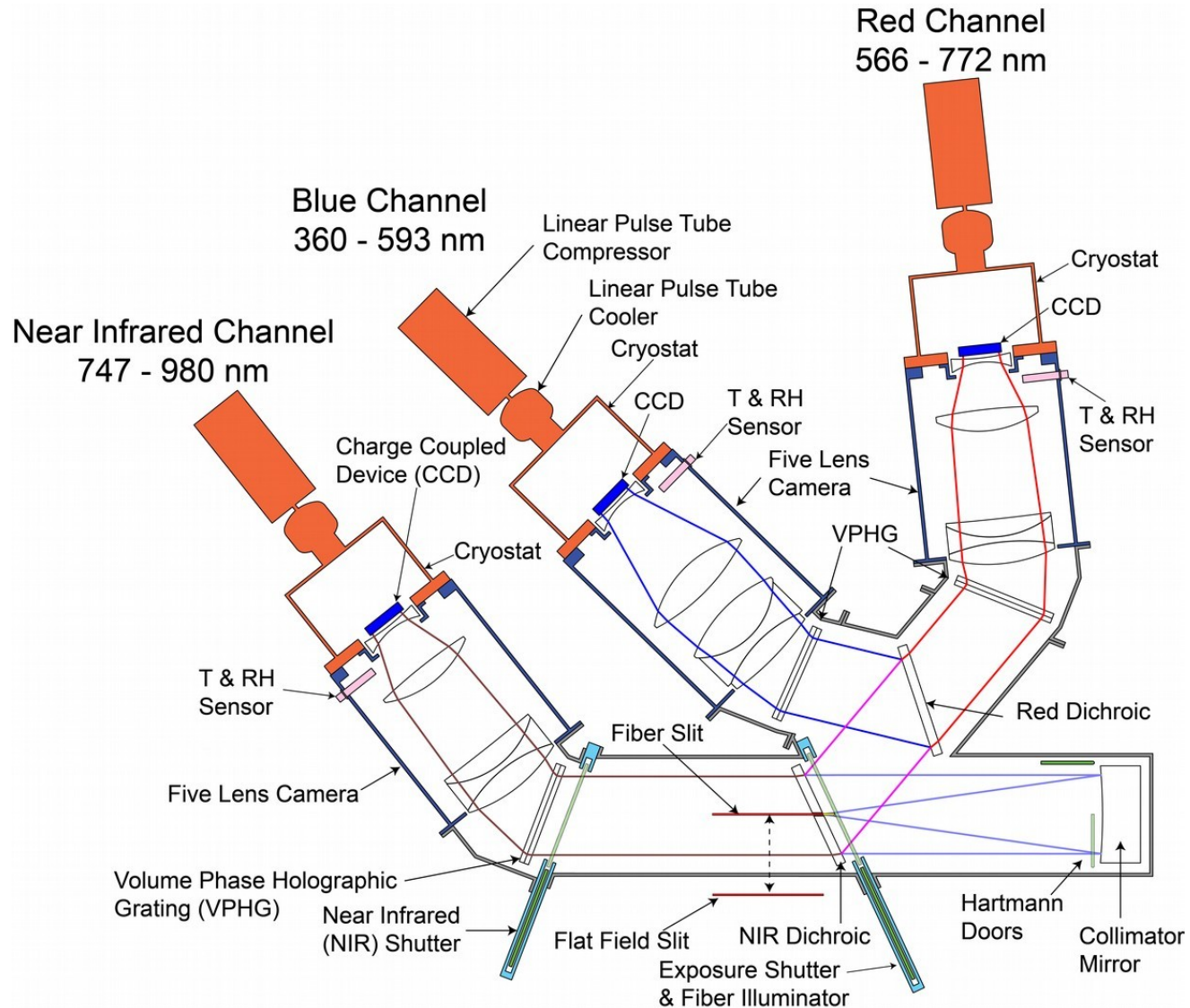

# Integrated LED flux [e-/s] on the 3 CCDs

- For **each LED**, for **each fiber 11 – 20**, a **separate exposure**
- Frames are reduced (DESI pipeline), spectrum region is integrated
- CCD amplifier gains [ADU → e-] are applied
- Resulting CCD flux [e-] is then **divided by the effective exposure time**
- The resulting spectrum is **integrated on the whole arm wavelength range**

$$\phi_{[e-/s]}^{\text{CCD}} = \frac{\text{gain}_{[e-/ADU]}^{\text{ampli}} \times \sum_{\text{ill. pixels}}^{\text{spectrum}} \phi_{[ADU]}^{\text{CCD}} (\text{pixel})}{\Delta t_{[s]}^{\text{exposure}}}$$

- **We need to calibrate the exposure time and the CCDs amplifiers gains**





# LED spectra

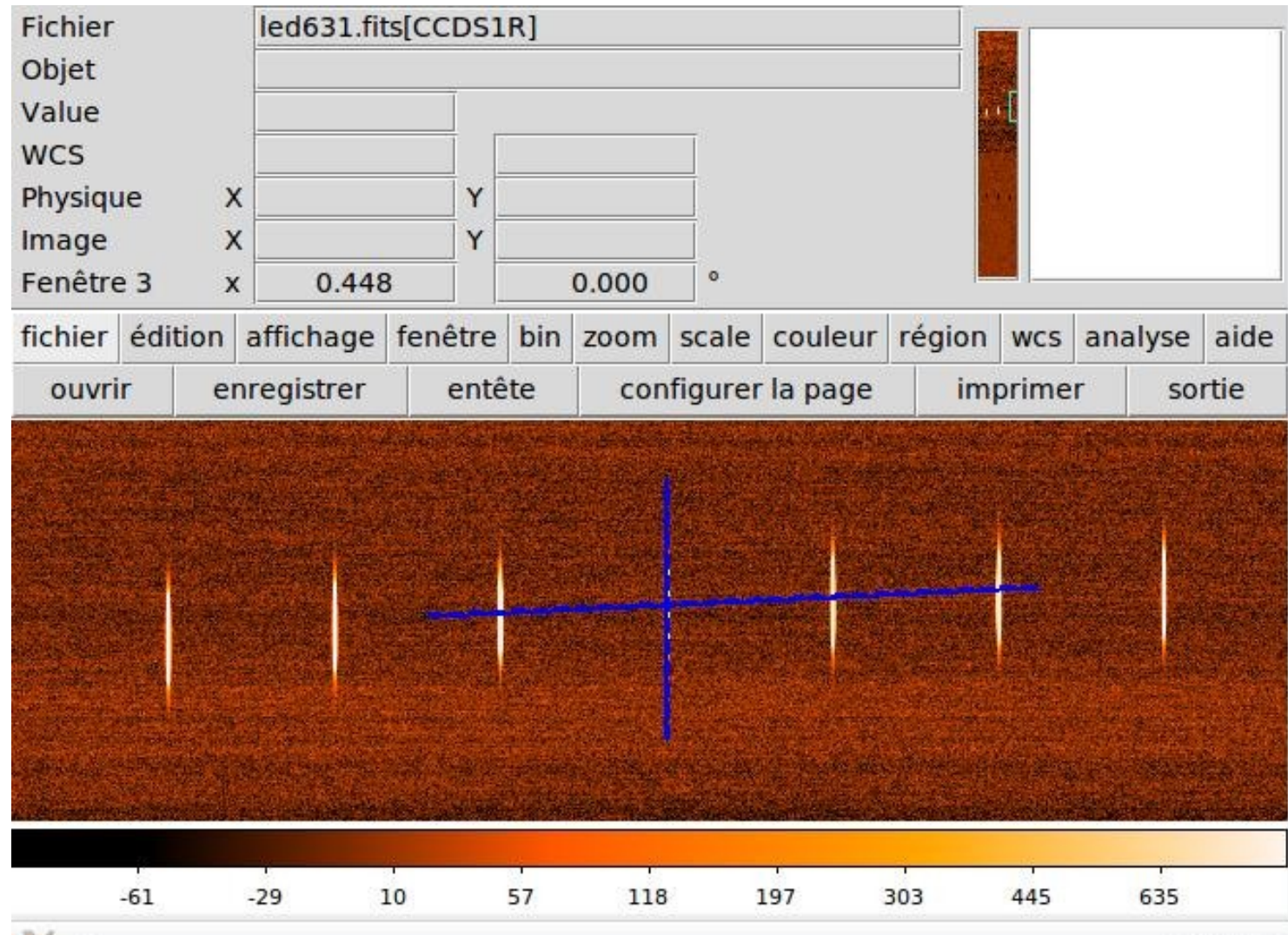

# LED spectrum extraction (pipeline JG)

- **Removing Bias / Dark current** (dark model)
- **Automatic extraction of all fiber spectra**
- **« Boxcar » : sum on 9 CCD pixel wide**
- Wavelength calibration from lamps and PSF model
  - Wavelength calibration better than 0.1 nm  
(no temperature correction)
- We verify that the **background is consistent with zero**
- We assume gain = 1 and the **gain correction is applied later**



# Spectrum in DESI arm B1: LED#1: 370 nm

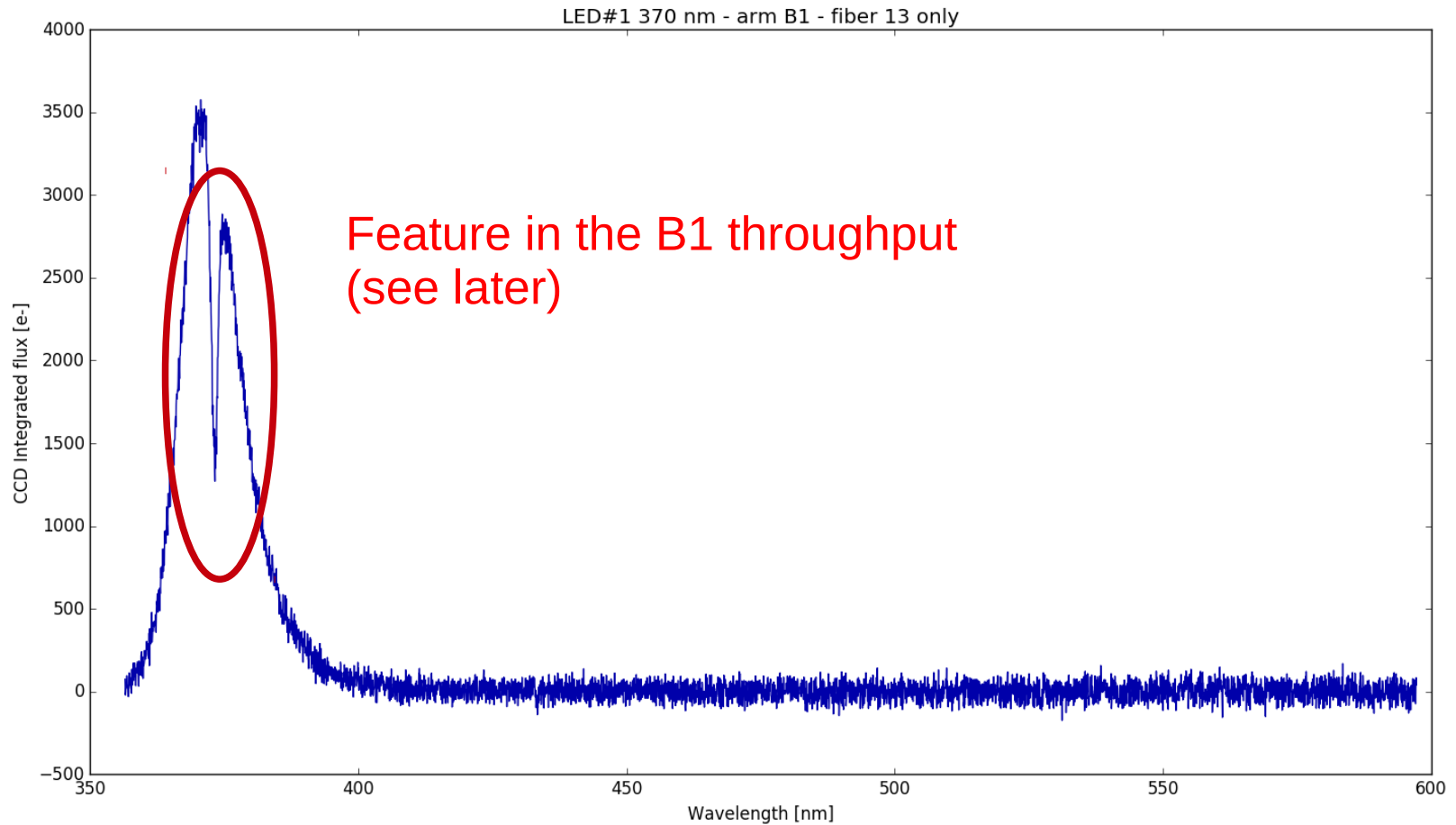



# Spectrum in DESI arm B1: LED#2: 465 nm

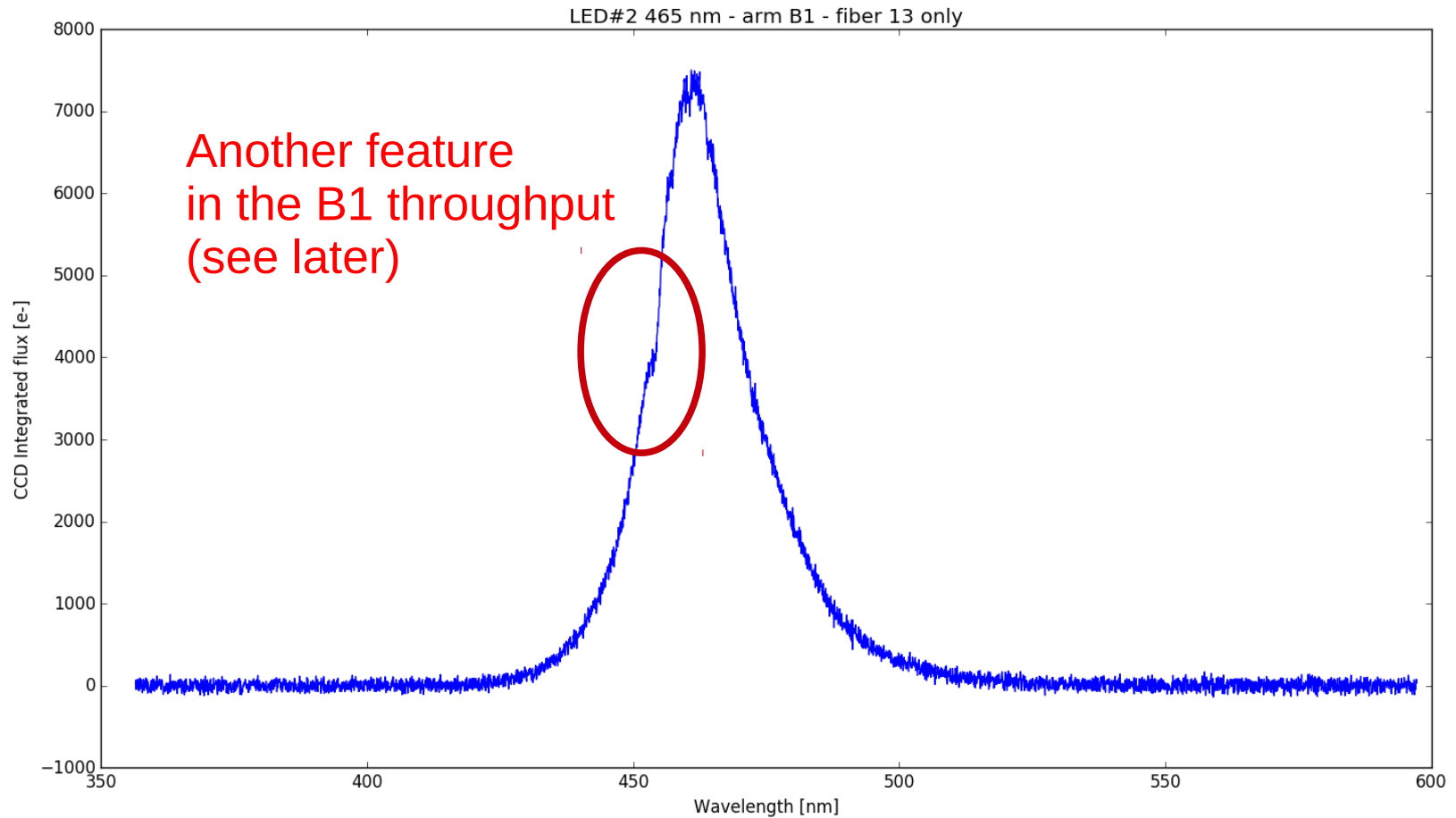

# Spectrum in DESI arm R1: LED#3: 591 nm

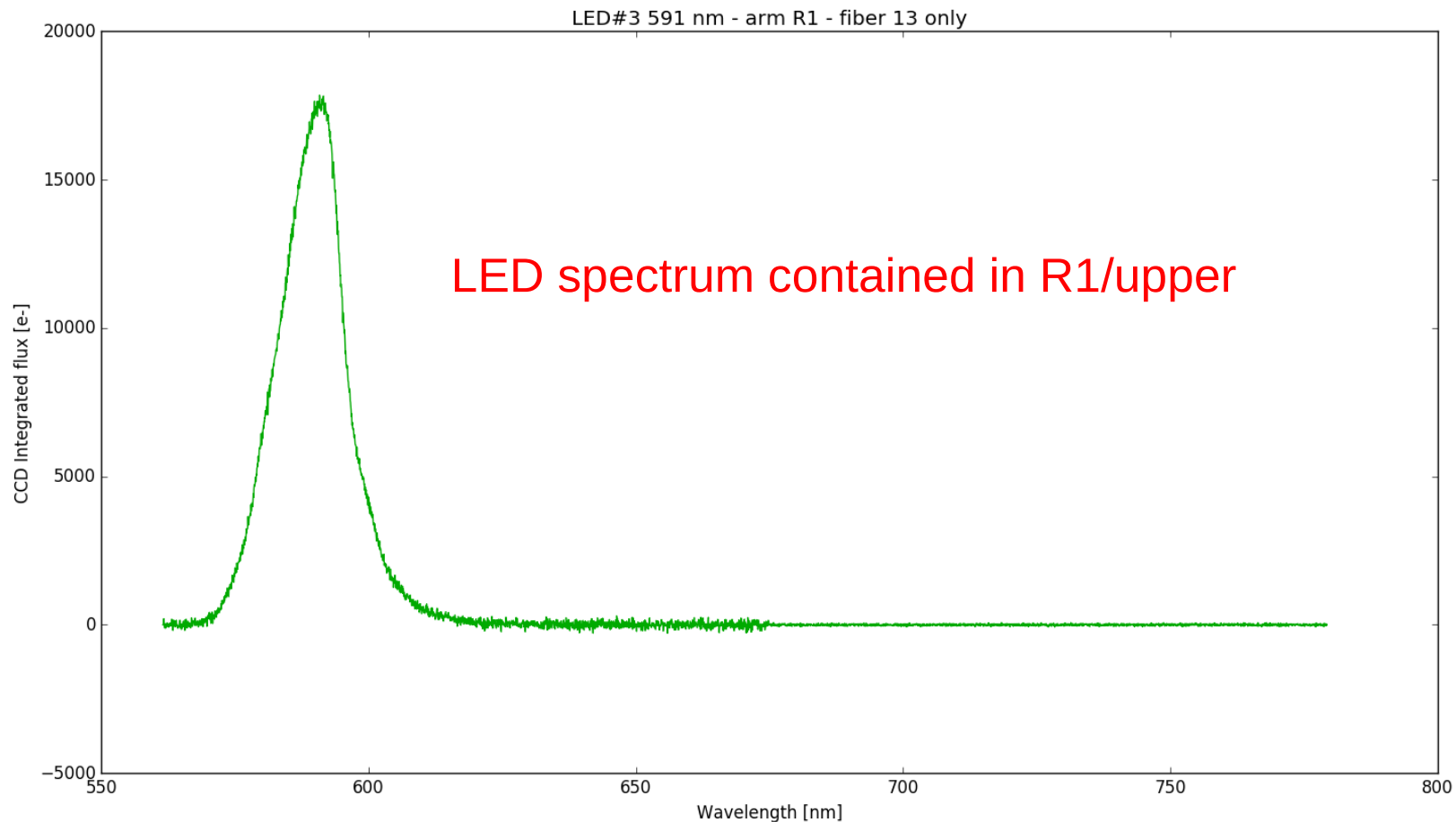

# Spectrum in DESI arm R1: LED#4: 631 nm

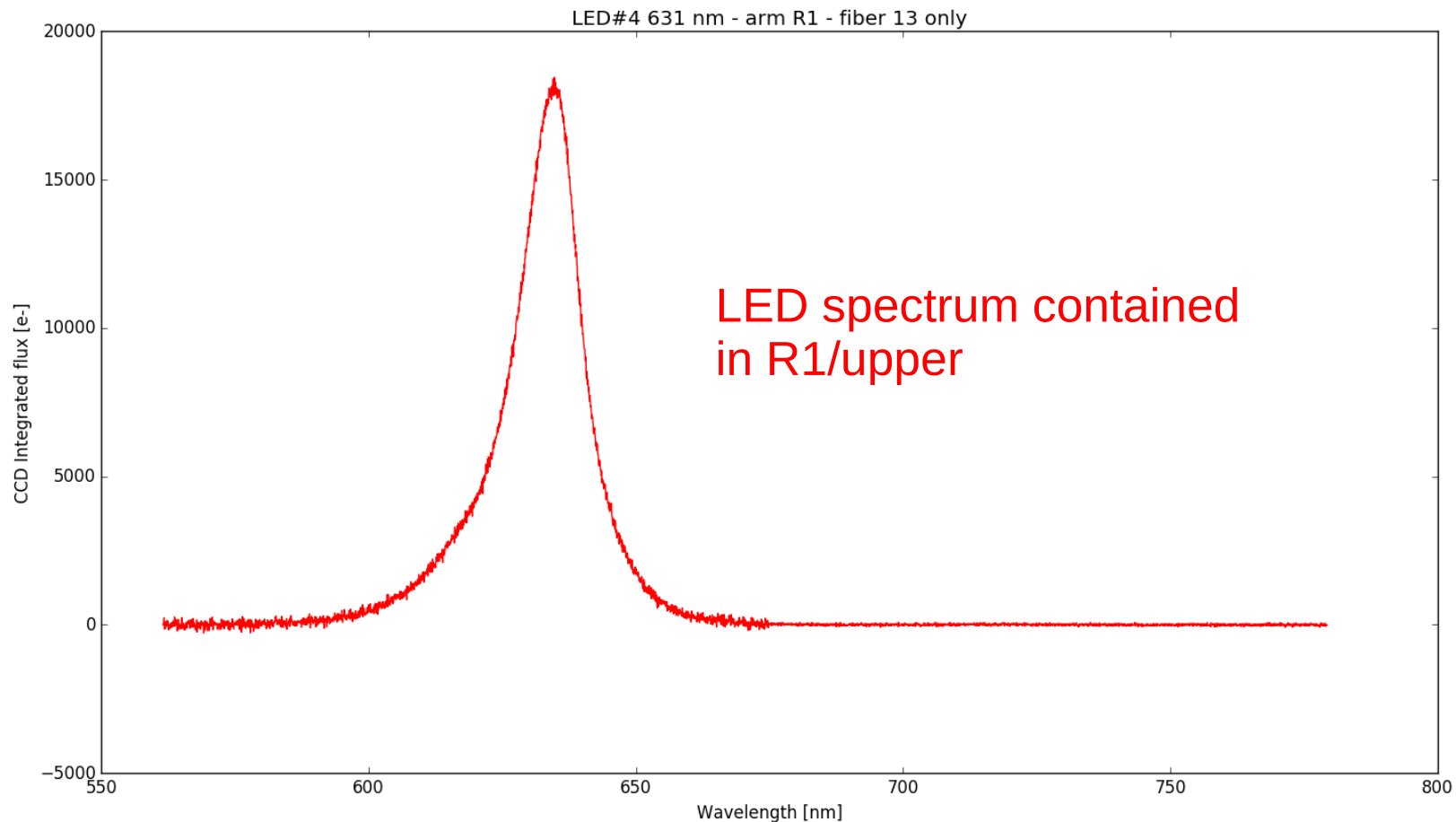



# Spectrum in DESI arm Z1: LED#5: 870 nm

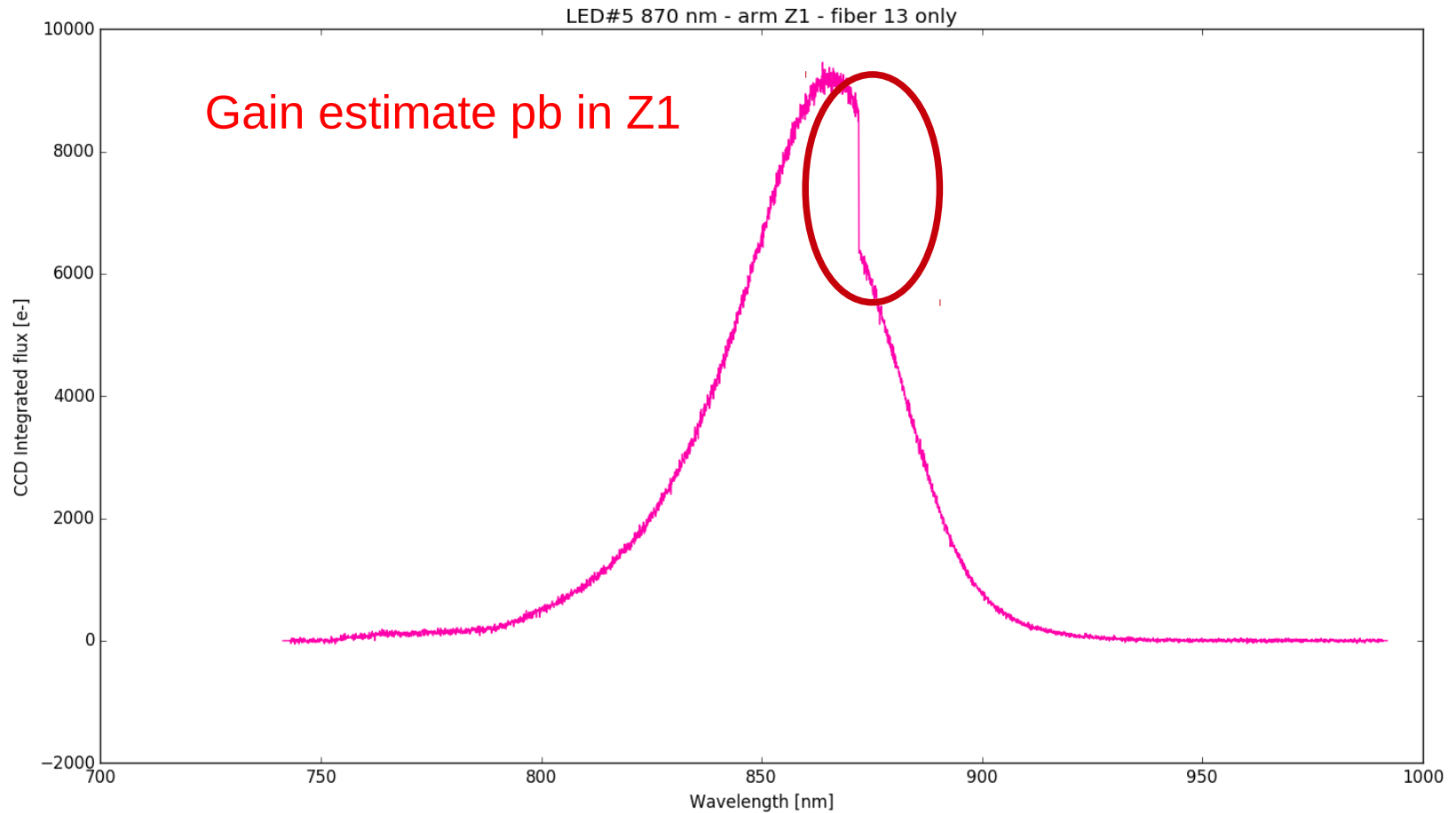

# Spectrum in DESI arm Z1: LED#6: 940 nm

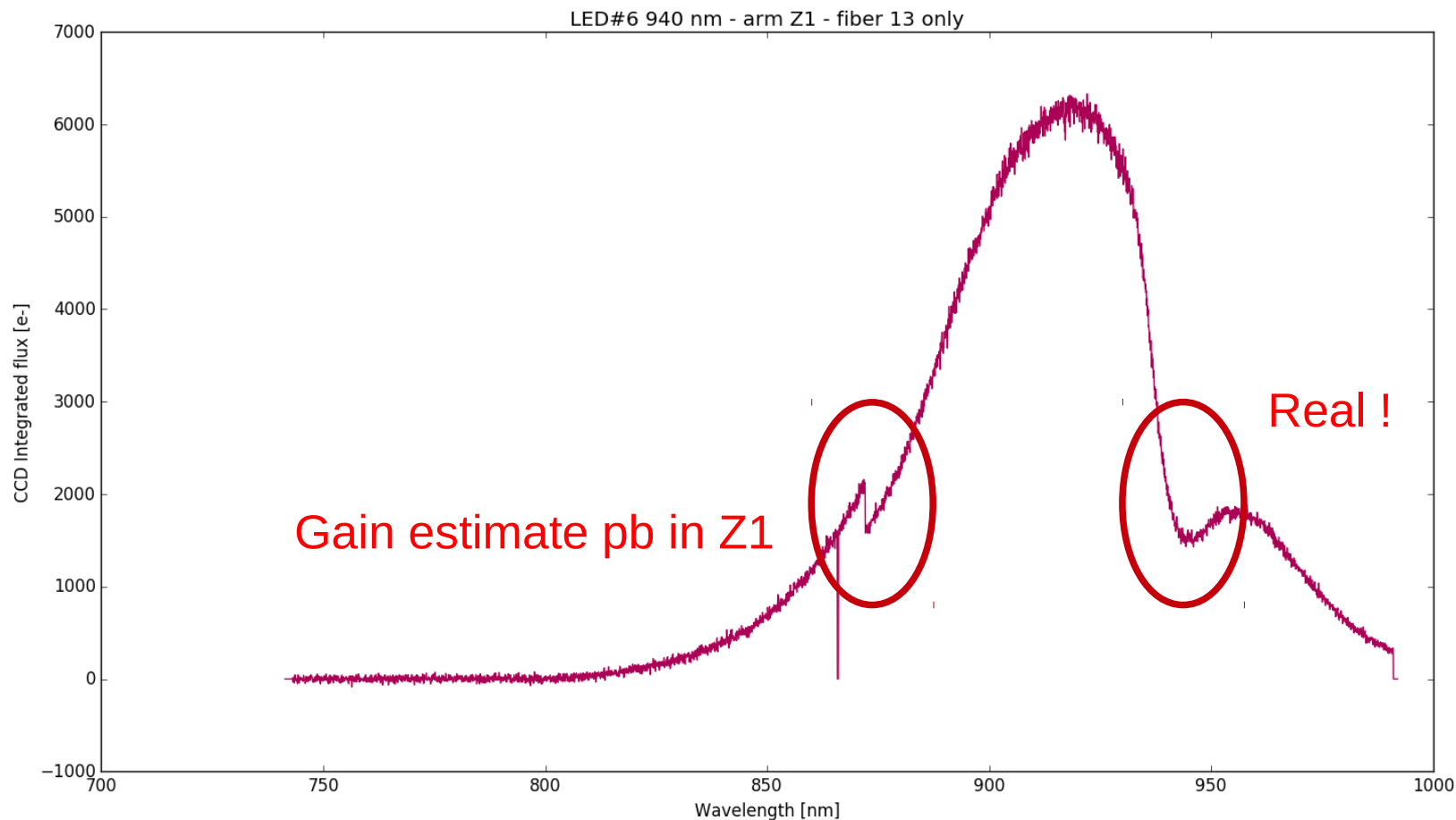

# Exposure time : shutter time correction

- Series of exposures with **increasing exposure time** and **different neutral densities** filters have been taken (first and second campaigns).
- Non-linearity corrections were needed.
- Assuming at least linearity for low fluxes, we were able to estimate an effective exposure time correction (same result on the 3 arms) :

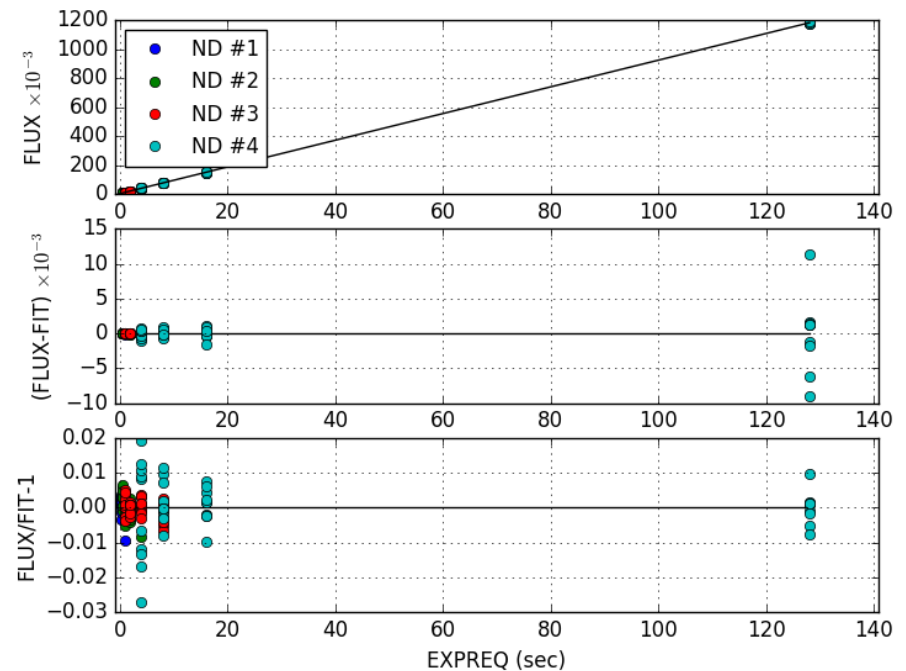

$$\Delta t_{\text{effective}} = [\text{EXPREQ}] + 0.36 \text{ s} \pm 0.01 \text{ s}$$

- **Q : What is EXPTIME (in FITS headers) ?**

(Vidéo shutter)





# Amplifier gain determination (DESI-2657)

- We measured the amplifier gains **with a PTC (Pixel Transfer Curve)** (variance versus mean flux curve)
- Amplifier gains were estimated in two ways :
  - **Tungsten lamp spectra** (DESI-2657),
    - ramp of exposure time, exposure pairs
  - **Flat with flat slit, tungsten**, (2017-03-29),
    - ramp of exposure time, exposure pairs



# Amplifier gain determination : PTC (arm B)

- **Building PTC** (photon transfer curve) for each **CCD amplifier**
- **b amplifiers** are reasonably **linear**
- **Using tungsten spectra**

Amplifier	gain
B1-A	0.587
B1-B	0.614
B1-C	0.630
B1-D	0.615

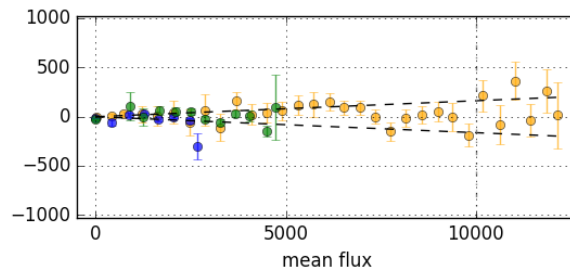
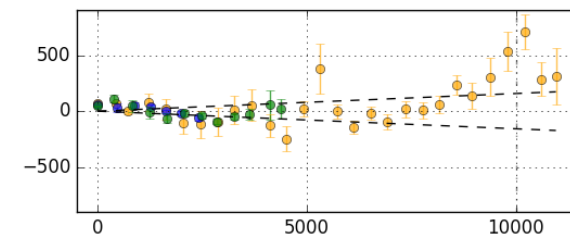
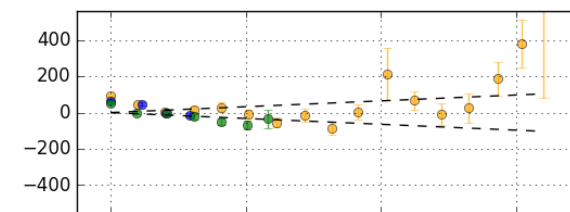
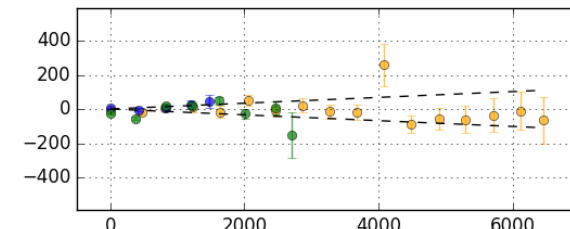
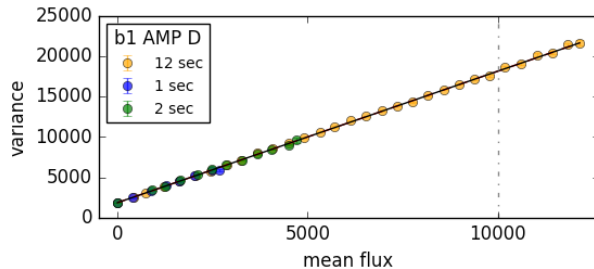
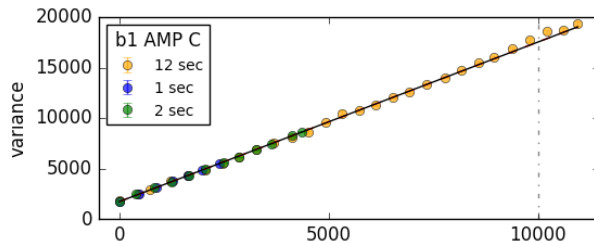
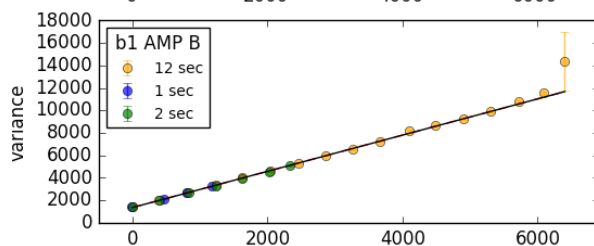
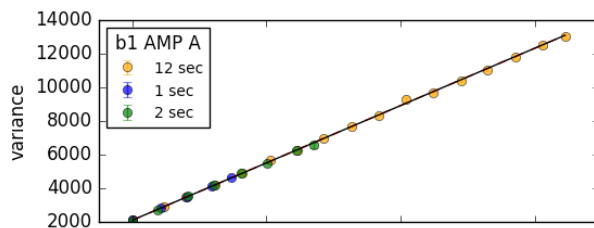

- **See DESI-2657 (JG)**



# Amplifier gain determination : PTC (arm R)

- Amplifier r1-A **unusable**
- **Other r amplifiers are reasonably linear**
- **Using tungsten spectra**

Amplifier	gain
R1-A	unusable
R1-B	1.658
R1-C	1.726
R1-D	1.723

- **See DESI-2657 (JG)**

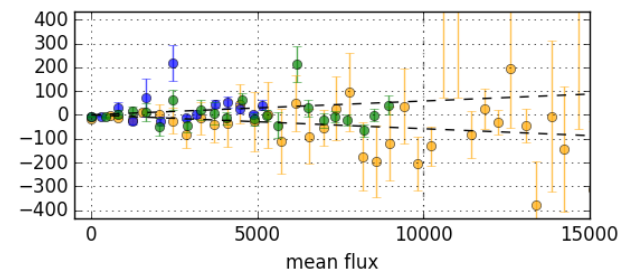
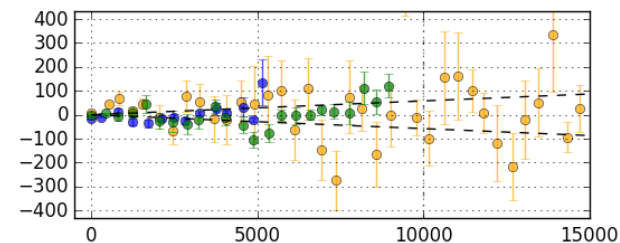
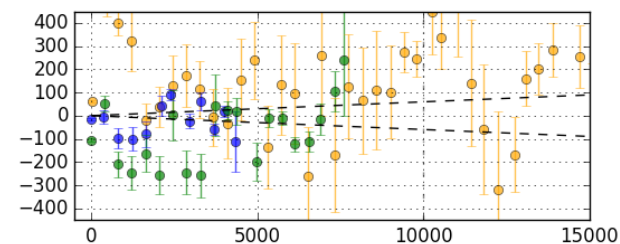
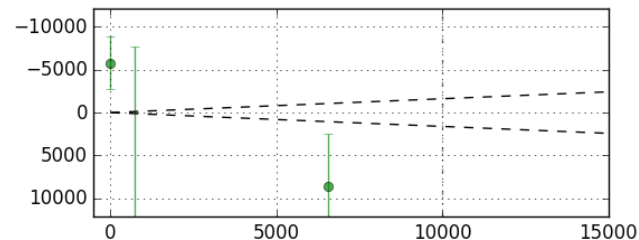
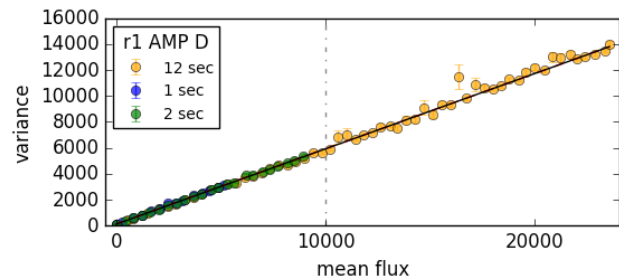
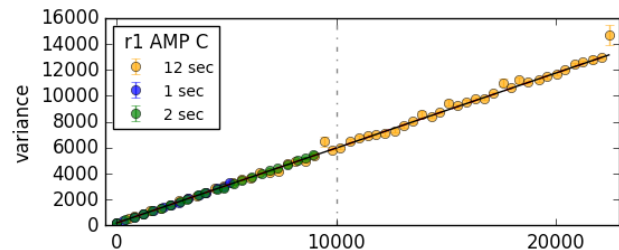
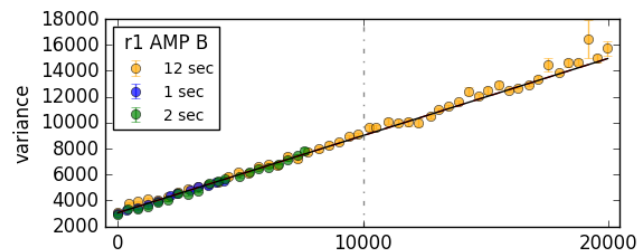
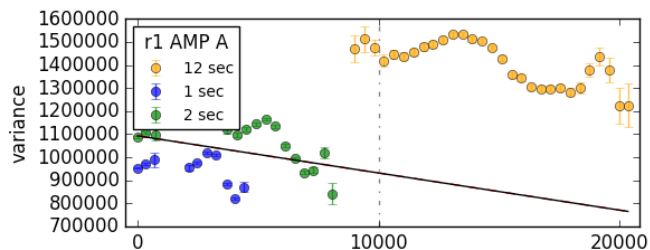

# Amplifier gain determination : PTC (arm Z)

- Highly non-linear amplis
- Z1-C unusable
- Using tungsten spectra

Amplifier	Gain (< 5000)
Z1-A	1.072
Z1-B	1.135
Z1-C	Unusable
Z1-D	0.774

- See DESI-2657 (JG)

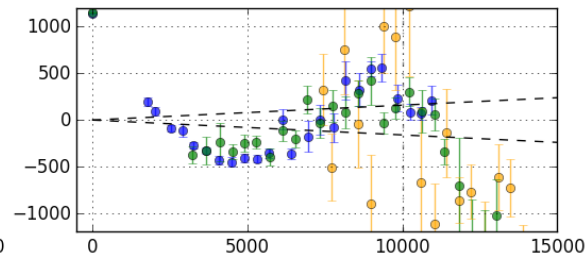
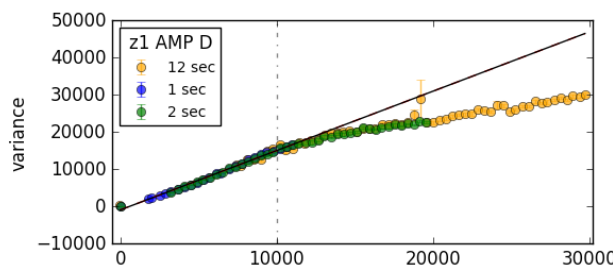
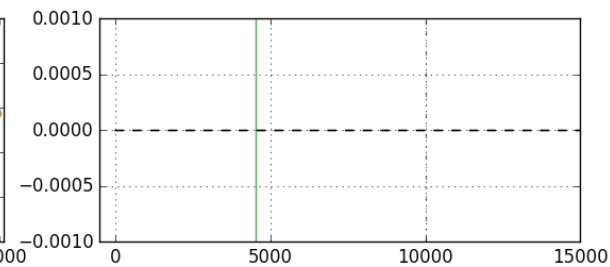
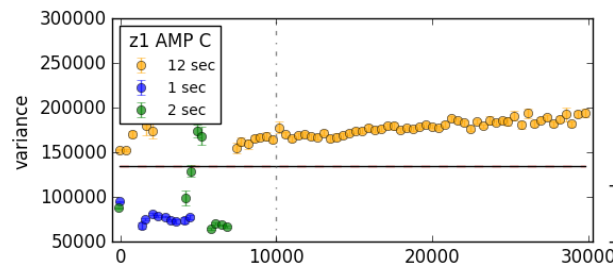
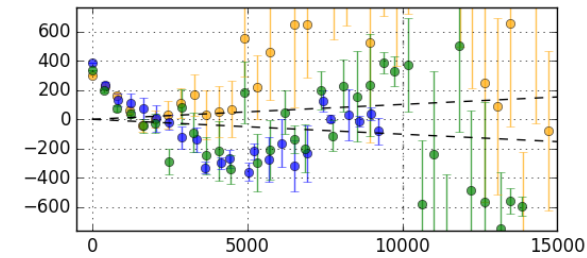
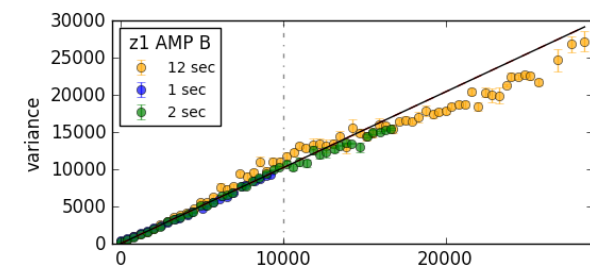
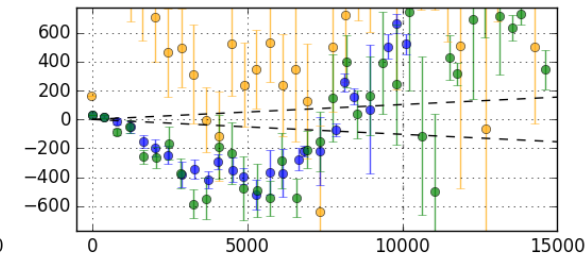
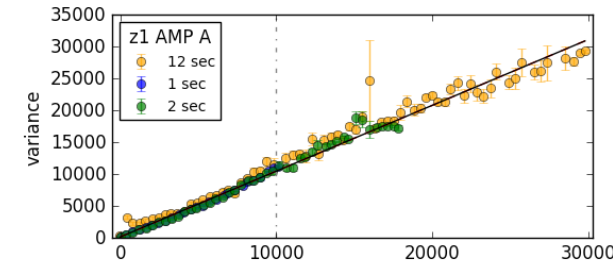



# Amplifier gain (flat slit, tungsten): b1-D

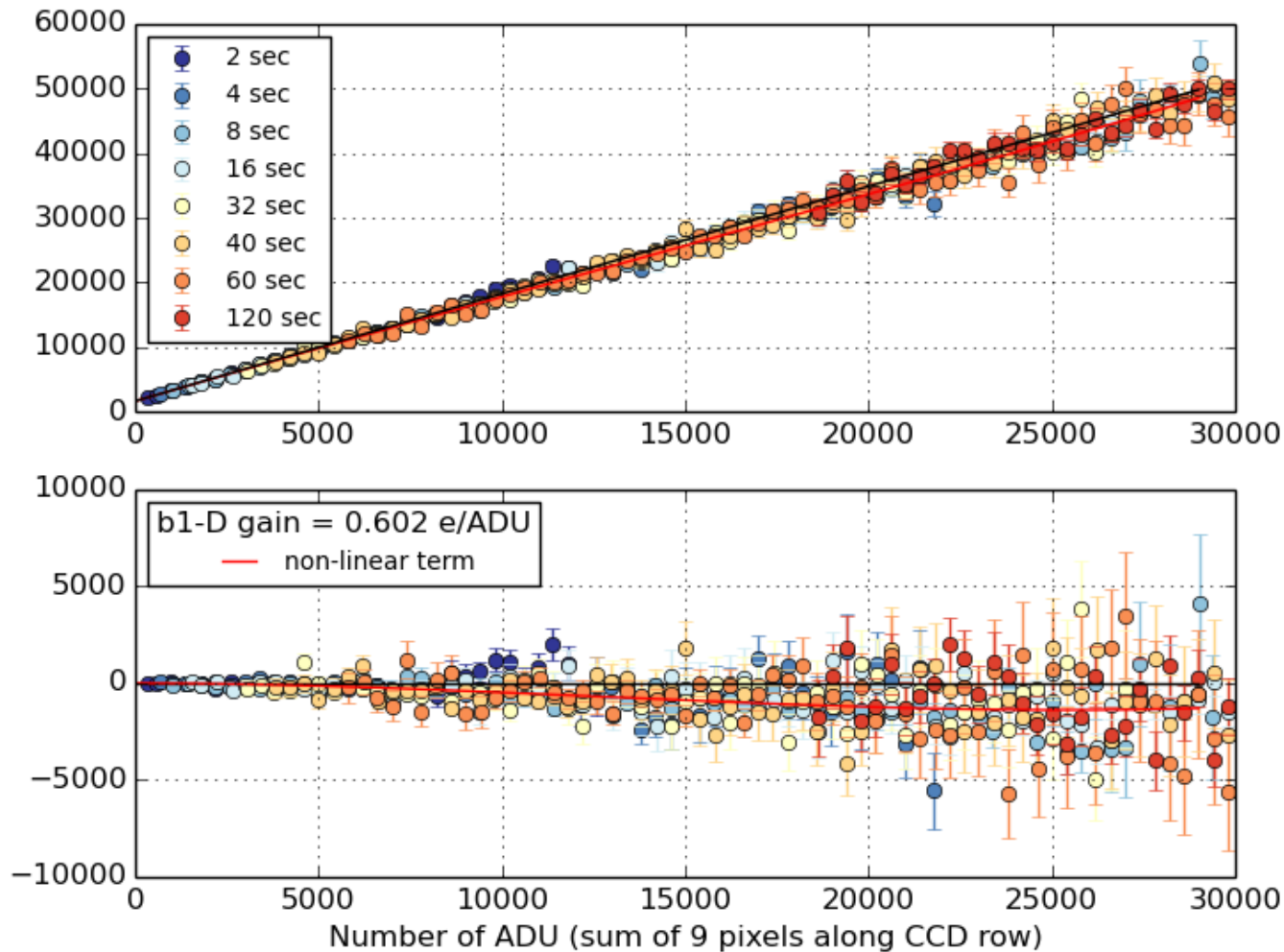

# Amplifier gain (flat slit, tungsten): r1-B

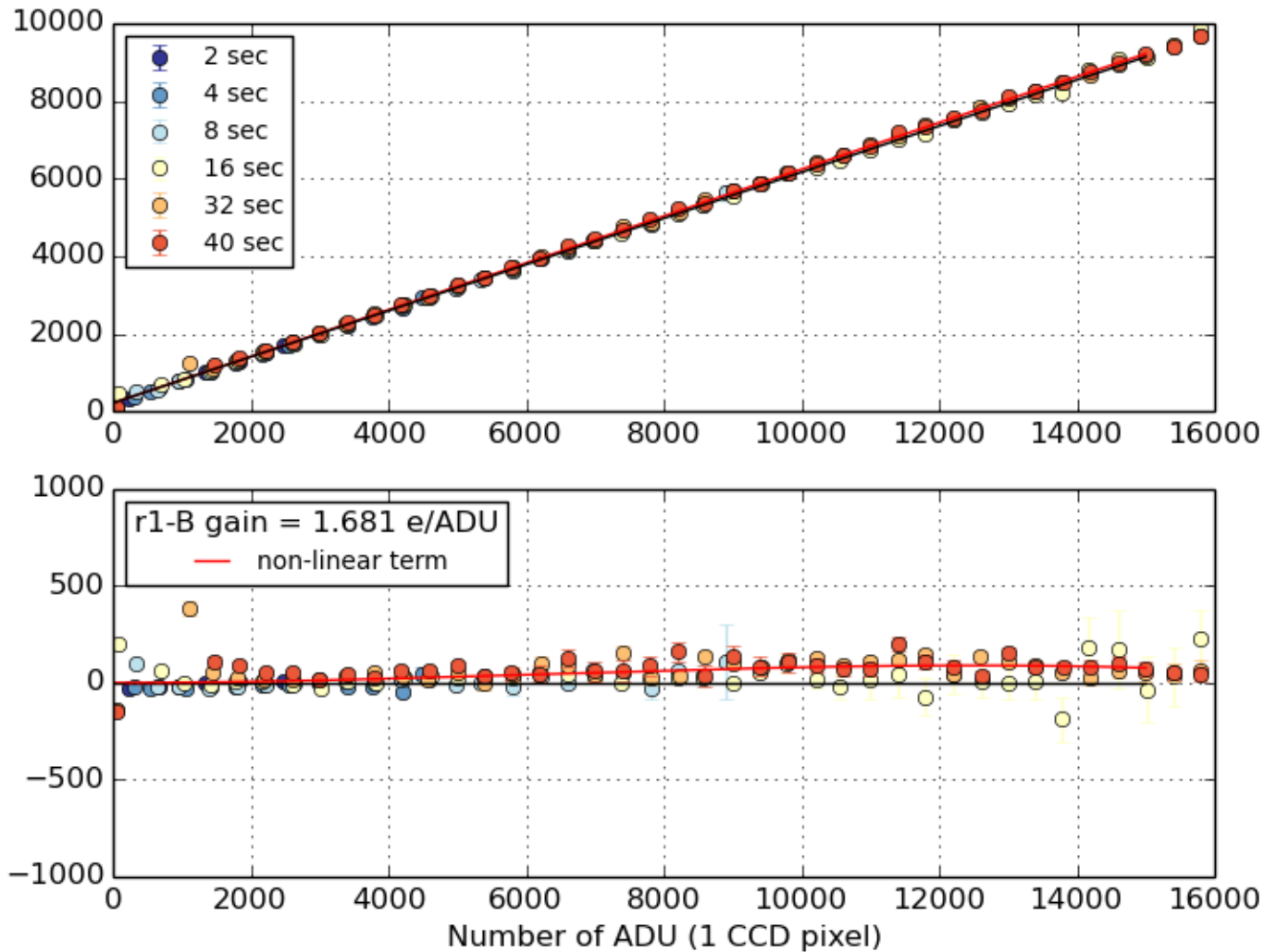

# Amplifier gain (flat slit, tungsten): z1-B

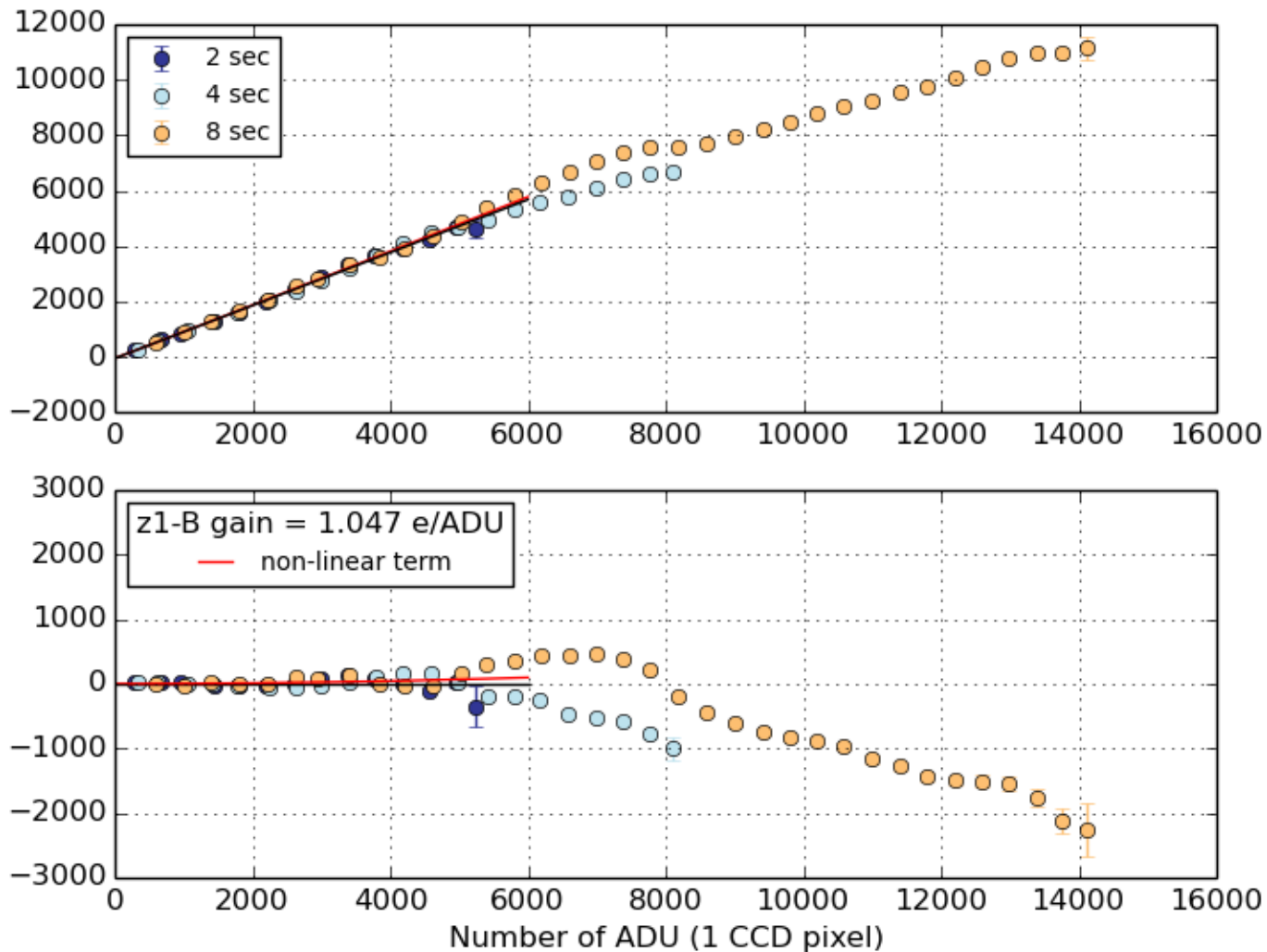

# Amplifier gain determination (flat slit, tungsten)

- Gains obtained with a PTC with **flat slit exposure, tungsten lamp** :

Amplifier	gain
B1-A	0.546
B1-B	0.619
B1-C	0.624
B1-D	0.602

Amplifier	gain
R1-A	unusable
R1-B	1.681
R1-C	1.666
R1-D	1.677

Amplifier	Gain (< 5000)
Z1-A	–
Z1-B	1.047
Z1-C	???
Z1-D	0.687

- For this analysis, we used the gains **obtained from the flat slit exposures** (seem more reliable)
- For **b1 & r1**, gain systematics around 3 %
- For **z1**, huge uncertainties due to the important non-linearity





# Measurement strategy: using fibers 11 – 20

- r1-A unusable
- z1-C unusable
- We choose to take LED spectra only with amplifiers B and D  
→ fibers 11 to 20
- Limiting the flux in all spectra (< 5000 ADU in all pixels) to avoid amplifiers non-linearity

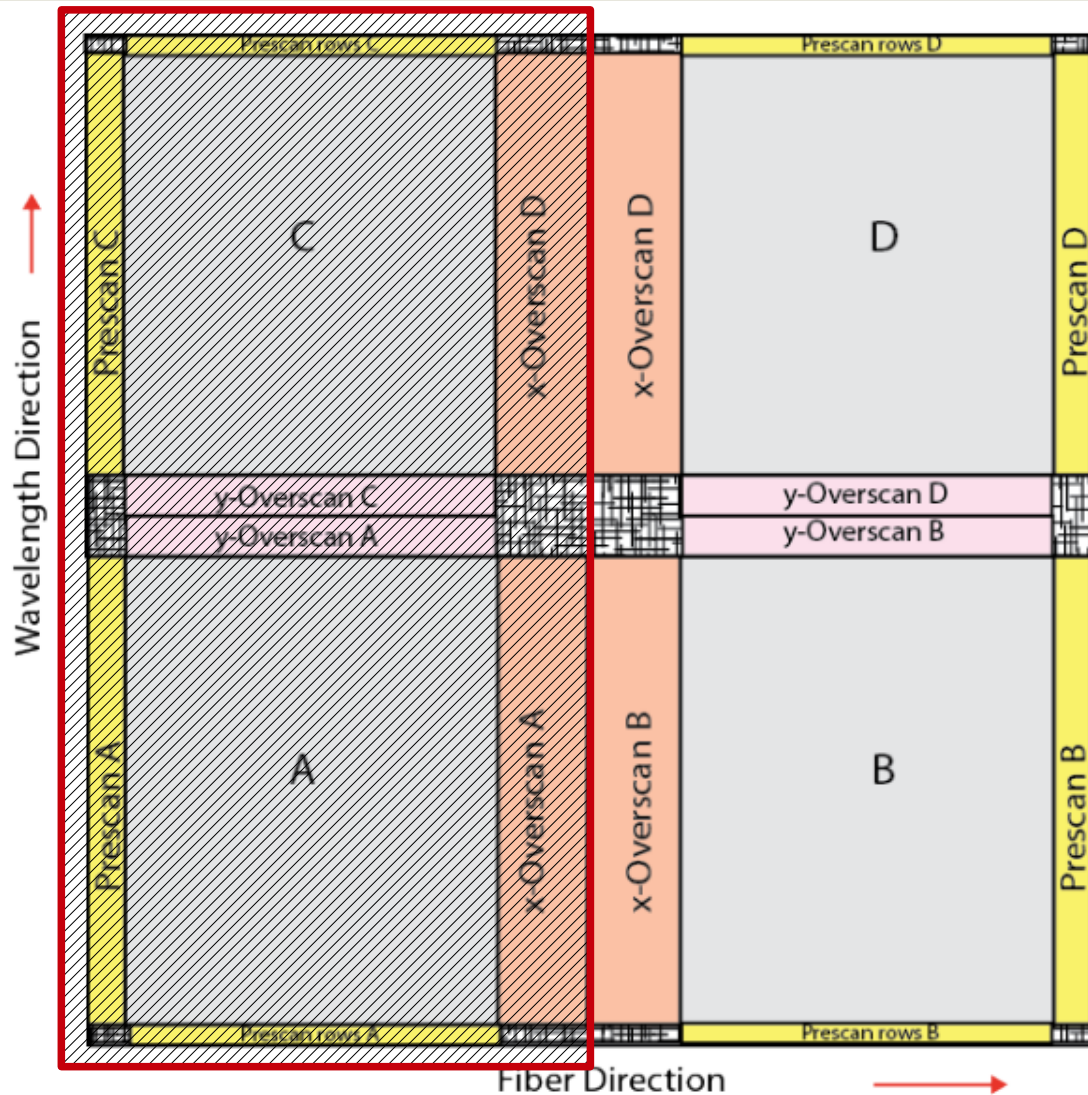

# Throughput measurement method

- Measurement to be done during **slit removal/reinstall** repeatability test (limited overhead)
- **Calibration of the total flux** at the exit of each fiber of the sparse fiber slit
- **Proposed Procedure** : for the same illumination setups (LEDs)
  - **(1) Sparse Test Slit outside of the spectrograph, in front of our device** : flux (in the same illumination conditions) measured by our calibrated photodiode for each LED / fiber ;
  - **(2) Sparse Test Slit inside the spectrograph** : integrated flux measured on the CCD for the 3 arms of the spectrograph for each LED / fiber ;
  - **Ratio (2)/(1) gives throughput (from fiber exit to the CCD included)**



# Direct throughput estimate (without a model)

- We first estimate the spectrograph throughput by **dividing the integrated flux in each CCD** (for each LED and each fiber 11-20) by the **injected flux (DKD)** :

$$\eta_{[e^-/\gamma]}(\lambda_{\text{LED}}) = (QE_{\text{CCD}} \times T_{\text{optics}}(\lambda_{\text{LED}})) = \frac{\phi_{[e^-/s]}^{\text{CCD}}(\text{LED})}{\phi_{[\gamma/s]}^{\text{injected}}(\text{LED})}$$

- For the moment, no FRD correction (see below).
- What we got that way is an **estimate of the spectrograph throughput** at the LED wavelength (weighted by the LED spectrum)
- Comparison with the **DESI optical model (without fibers)**



# Direct throughput estimate (without a model)

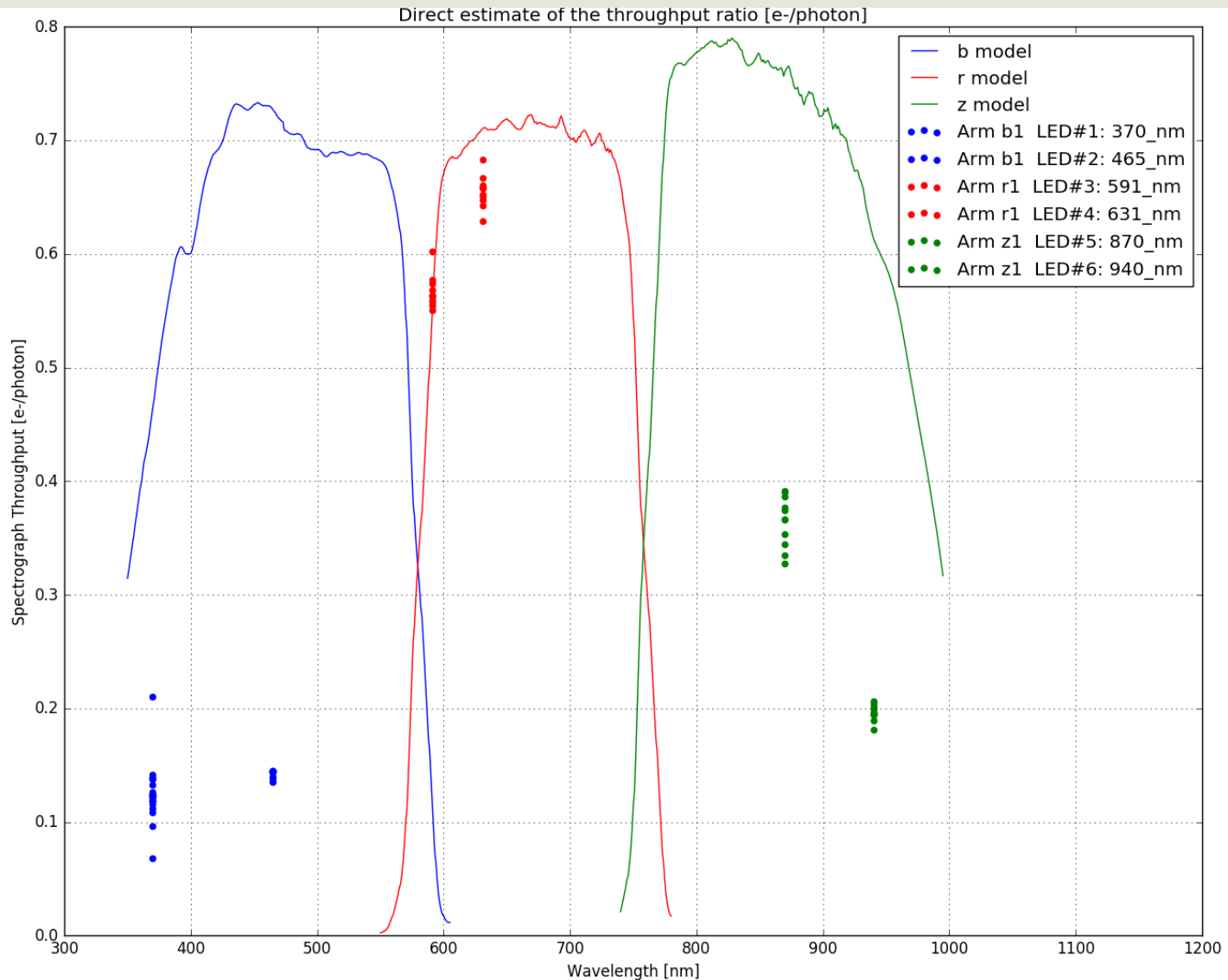



Direct estimate of the throughput ratio [e-/photon]

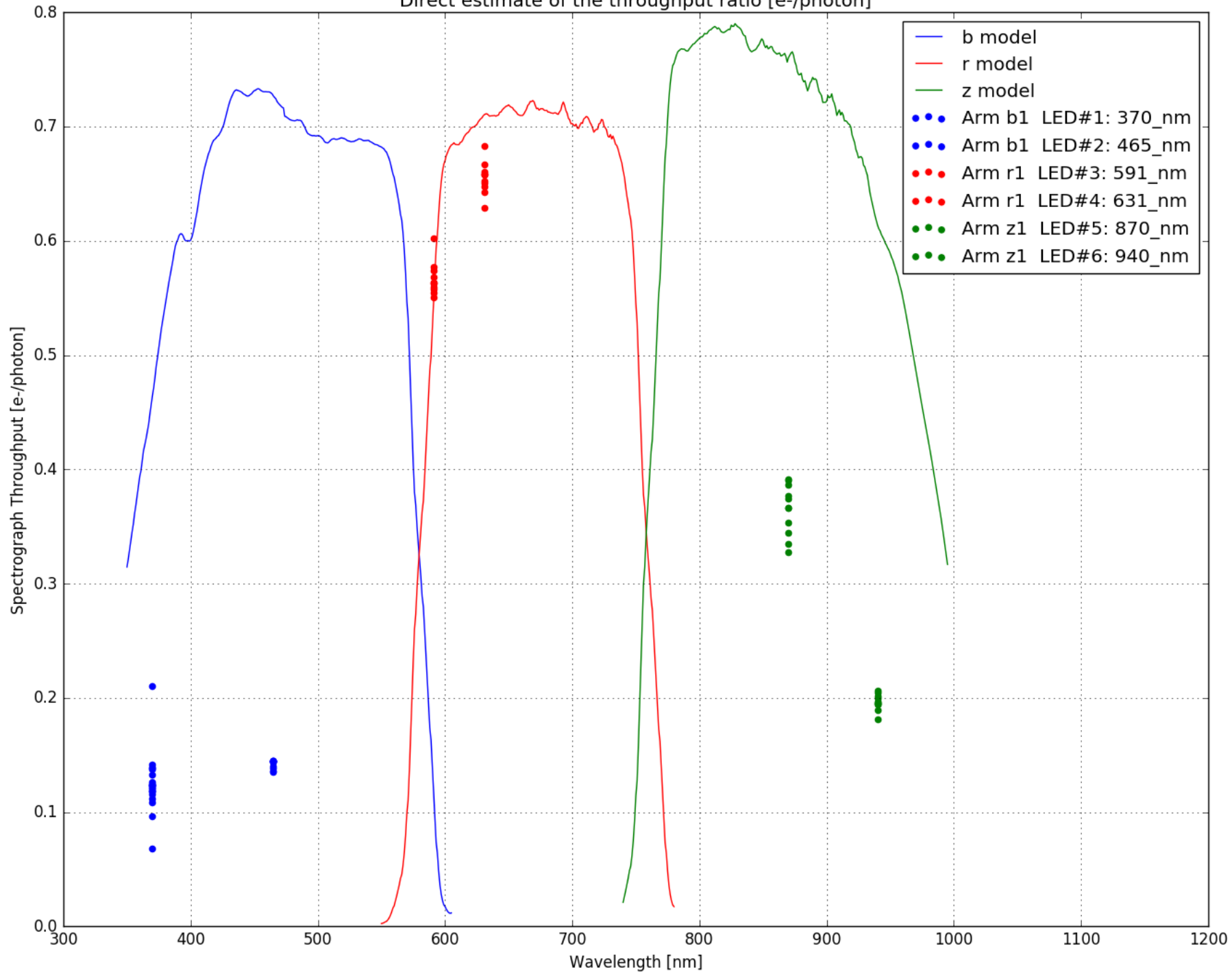

Direct estimate of the throughput ratio [e-/photon]

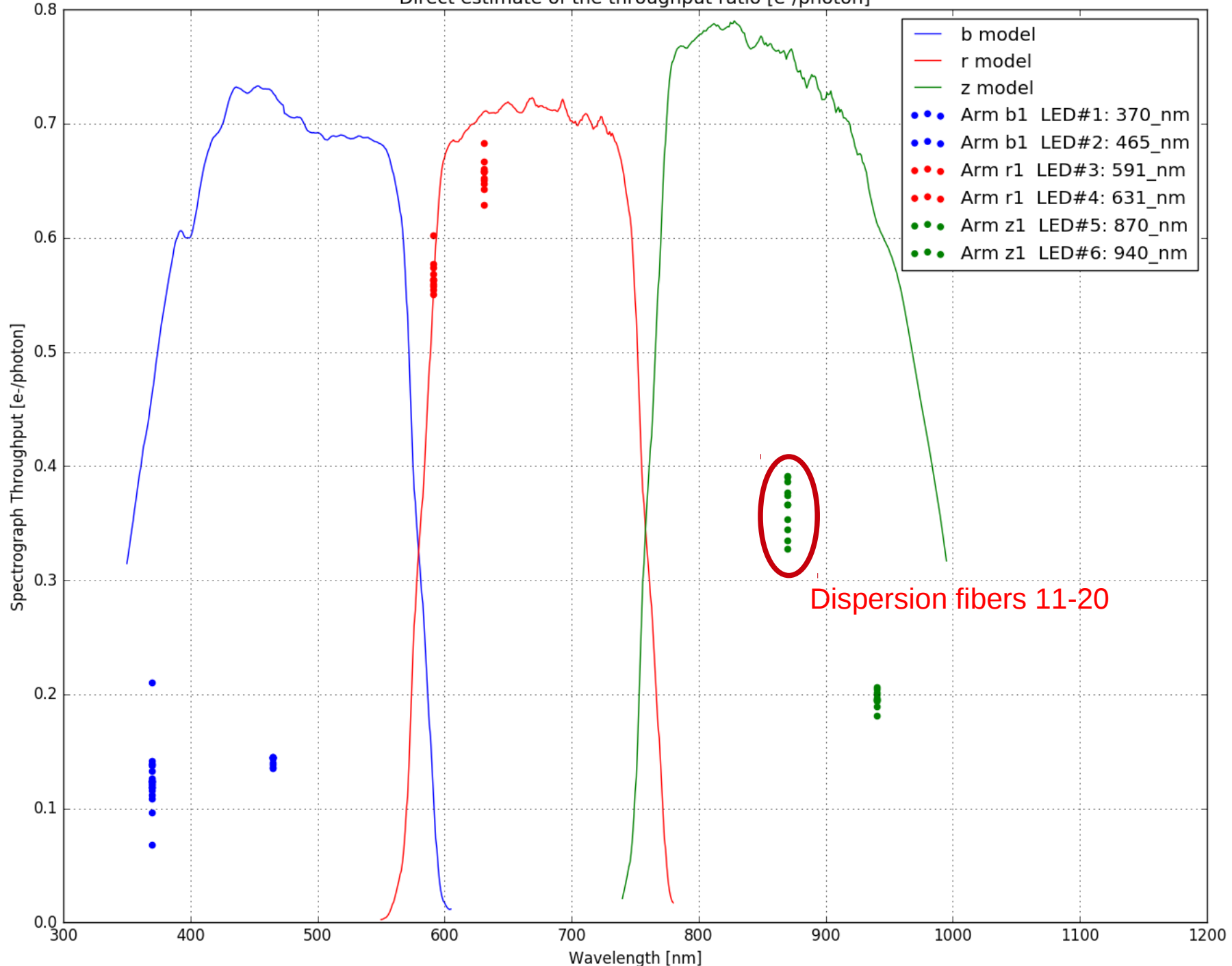

- b model
- r model
- z model
- Arm b1 LED#1: 370\_nm
- Arm b1 LED#2: 465\_nm
- Arm r1 LED#3: 591\_nm
- Arm r1 LED#4: 631\_nm
- Arm z1 LED#5: 870\_nm
- Arm z1 LED#6: 940\_nm

Dispersion fibers 11-20

# Throughput shape from Tungsten lamp exposures

- Derived from Tungsten lamp exposures
- Hypotheses on Tungsten spectrum (blackbody, Thorlabs specs)
- Normalisation to be determined ! Gives the shape of the throughput function
- « Absorption » features : some are real and also seen in LED spectra (see below)

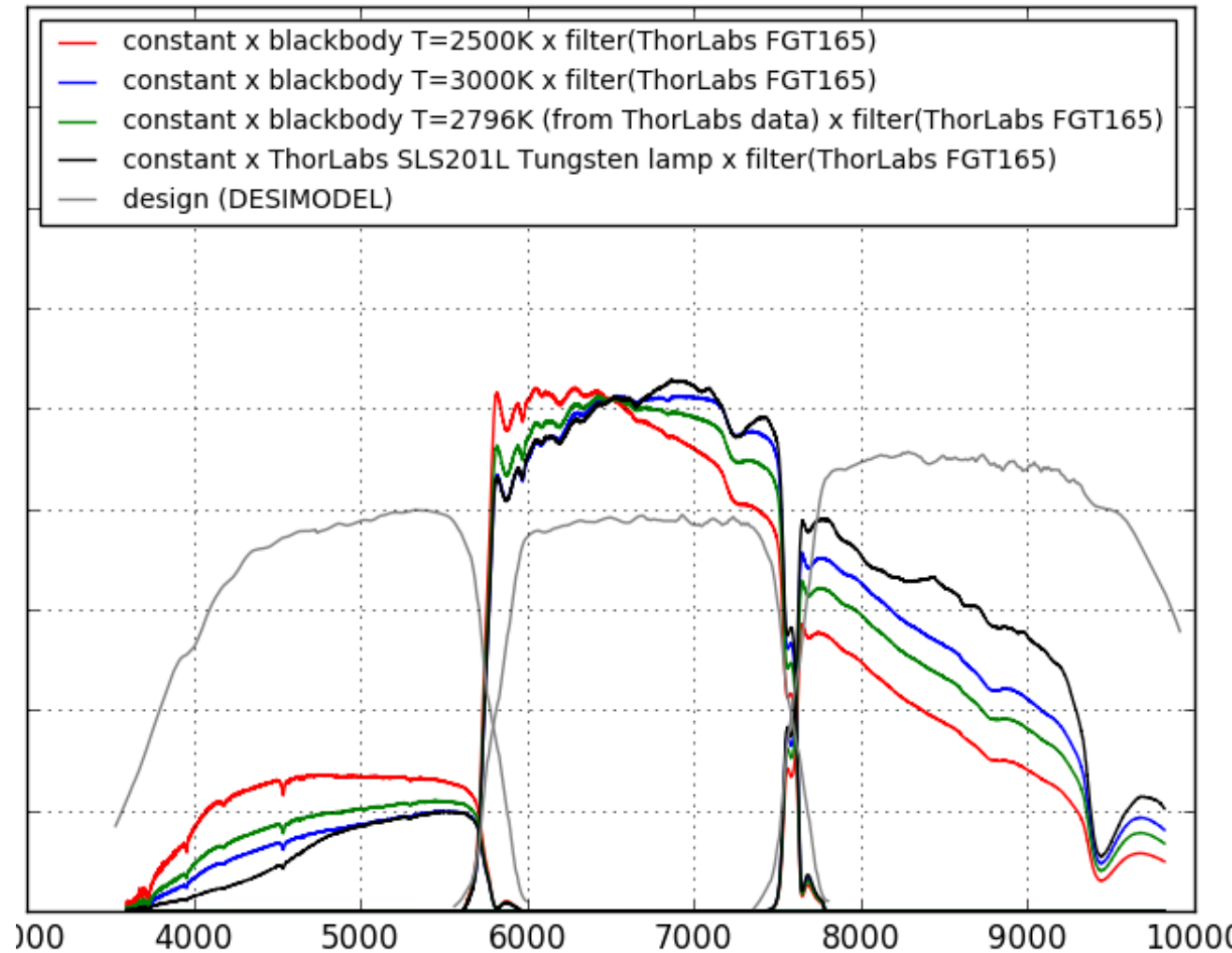

# Spectrum in DESI arm B1: LED#1: 370 nm

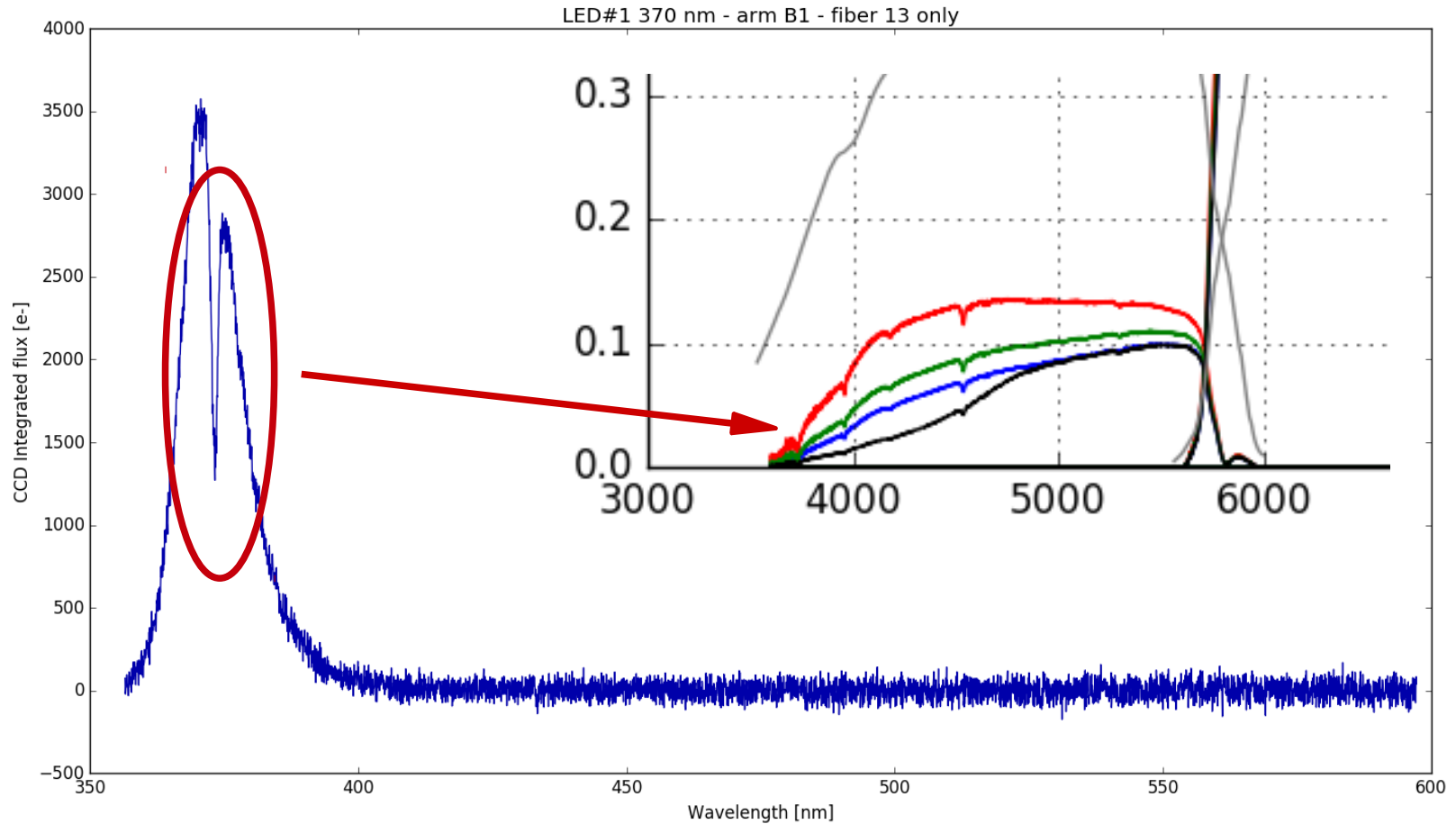



# Spectrum in DESI arm B1: LED#2: 465 nm

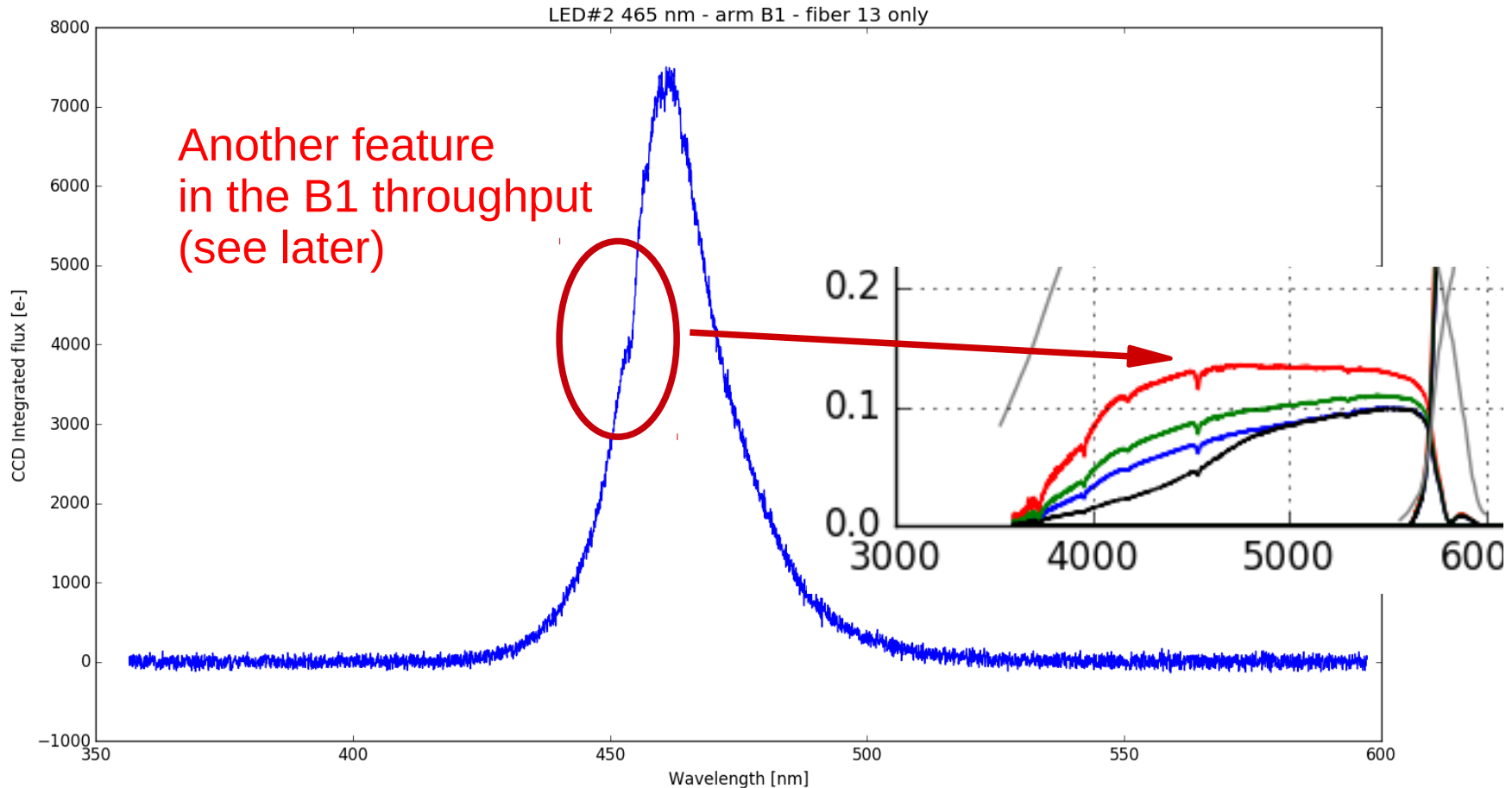

# Spectrum in DESI arm R1: LED#3: 591 nm

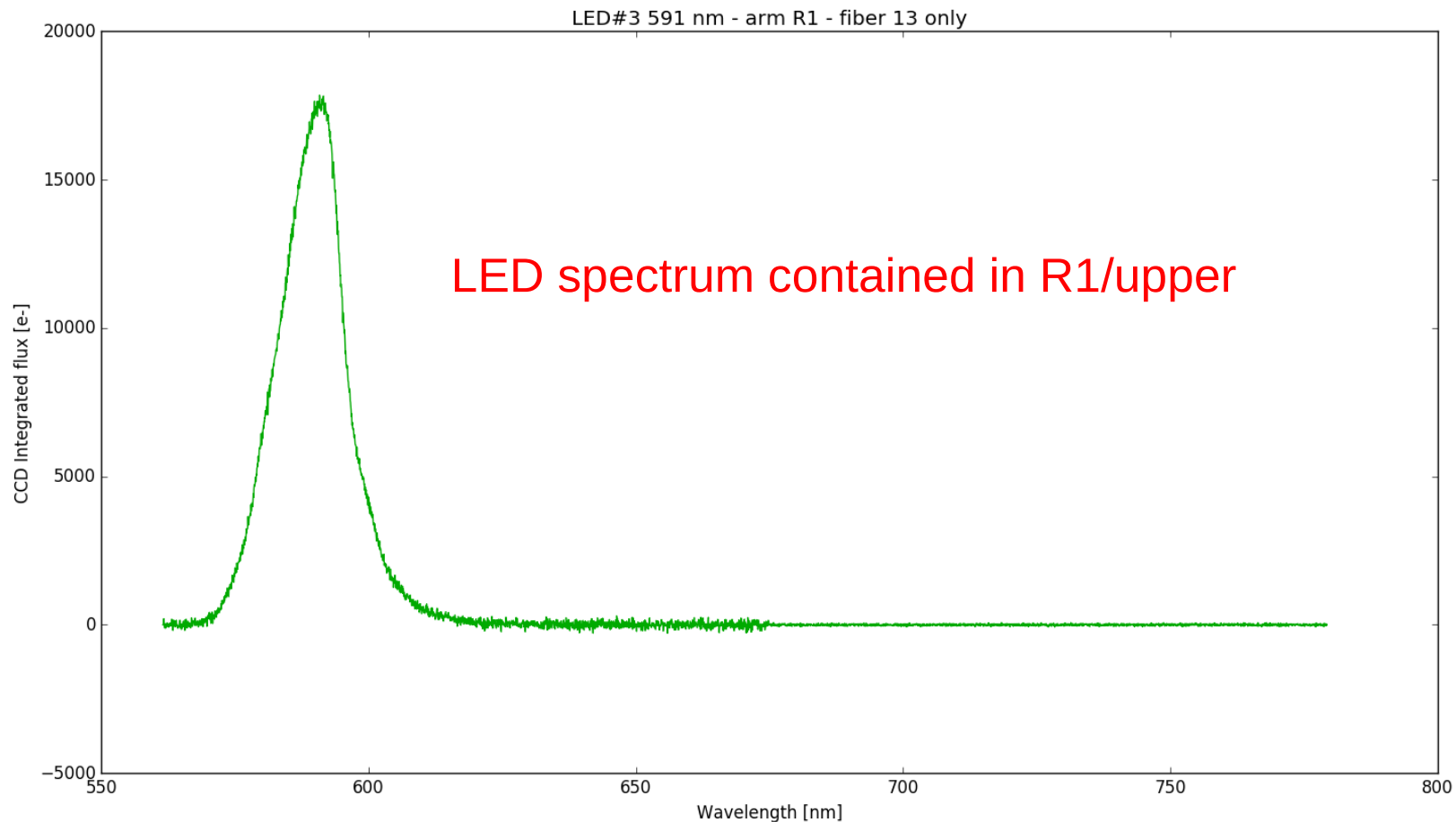

# Spectrum in DESI arm R1: LED#4: 631 nm

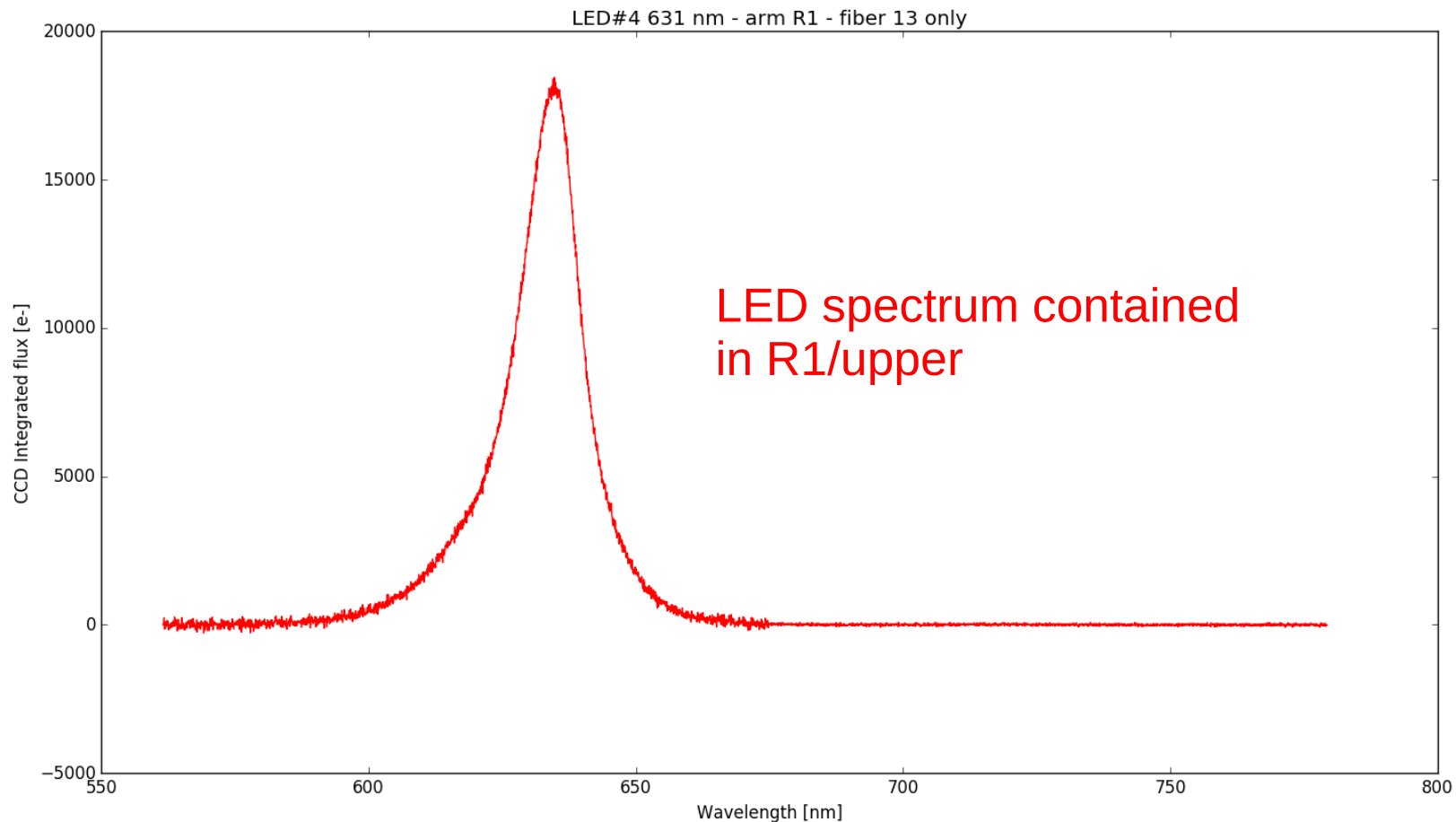

# Spectrum in DESI arm Z1: LED#5: 870 nm

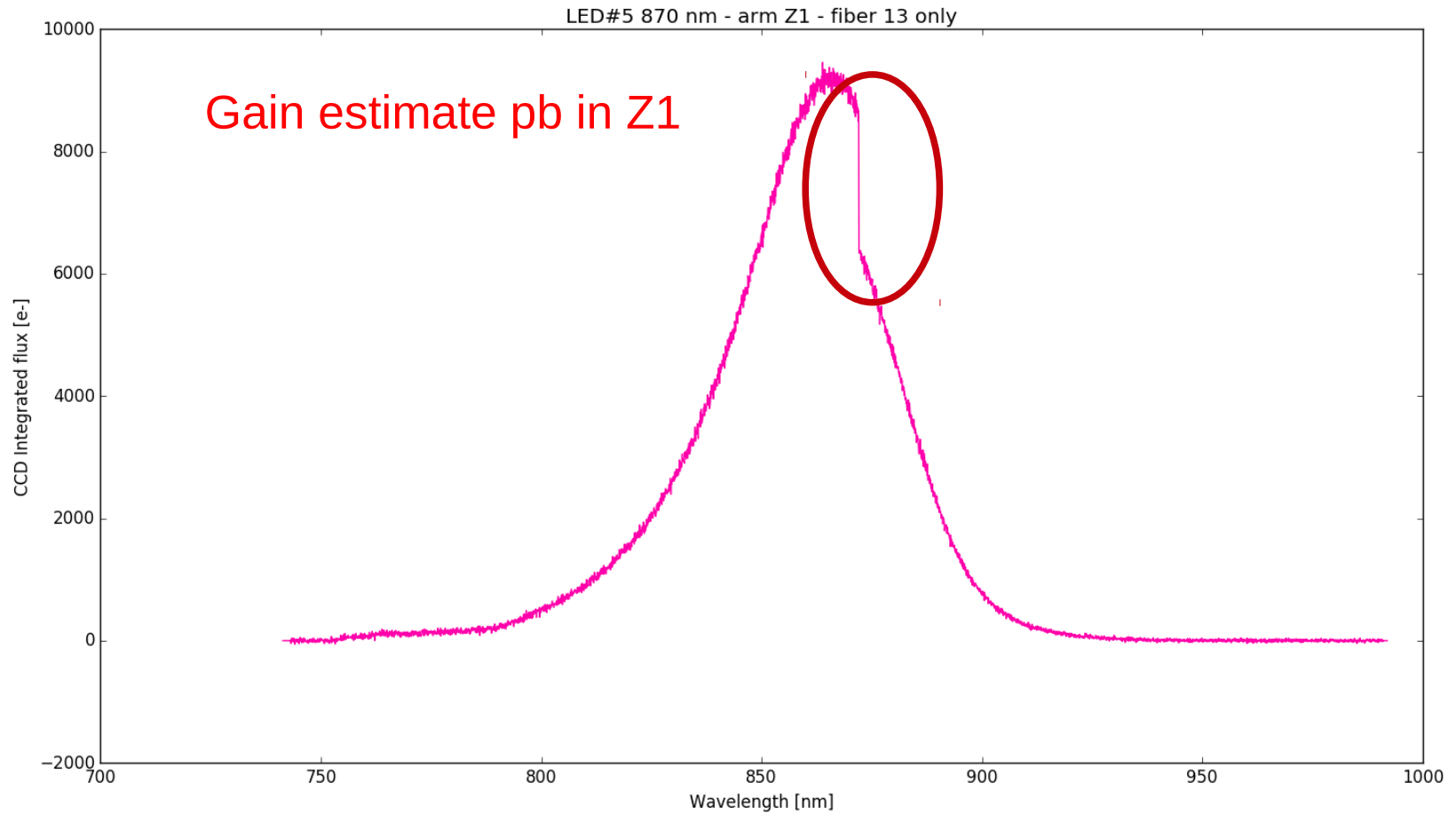



# Spectrum in DESI arm Z1: LED#6: 940 nm

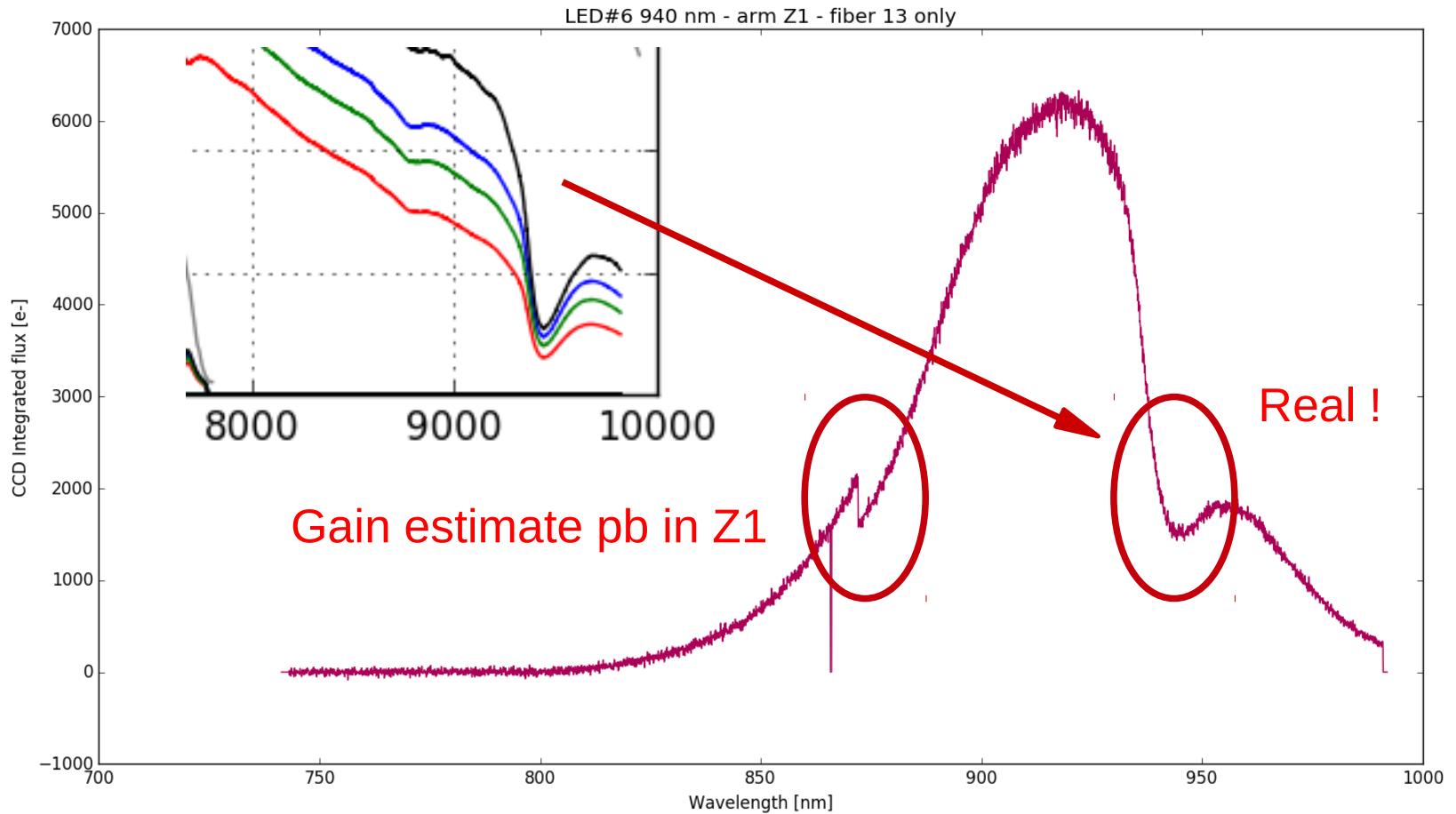

# Anchoring Tungsten to LED measurements

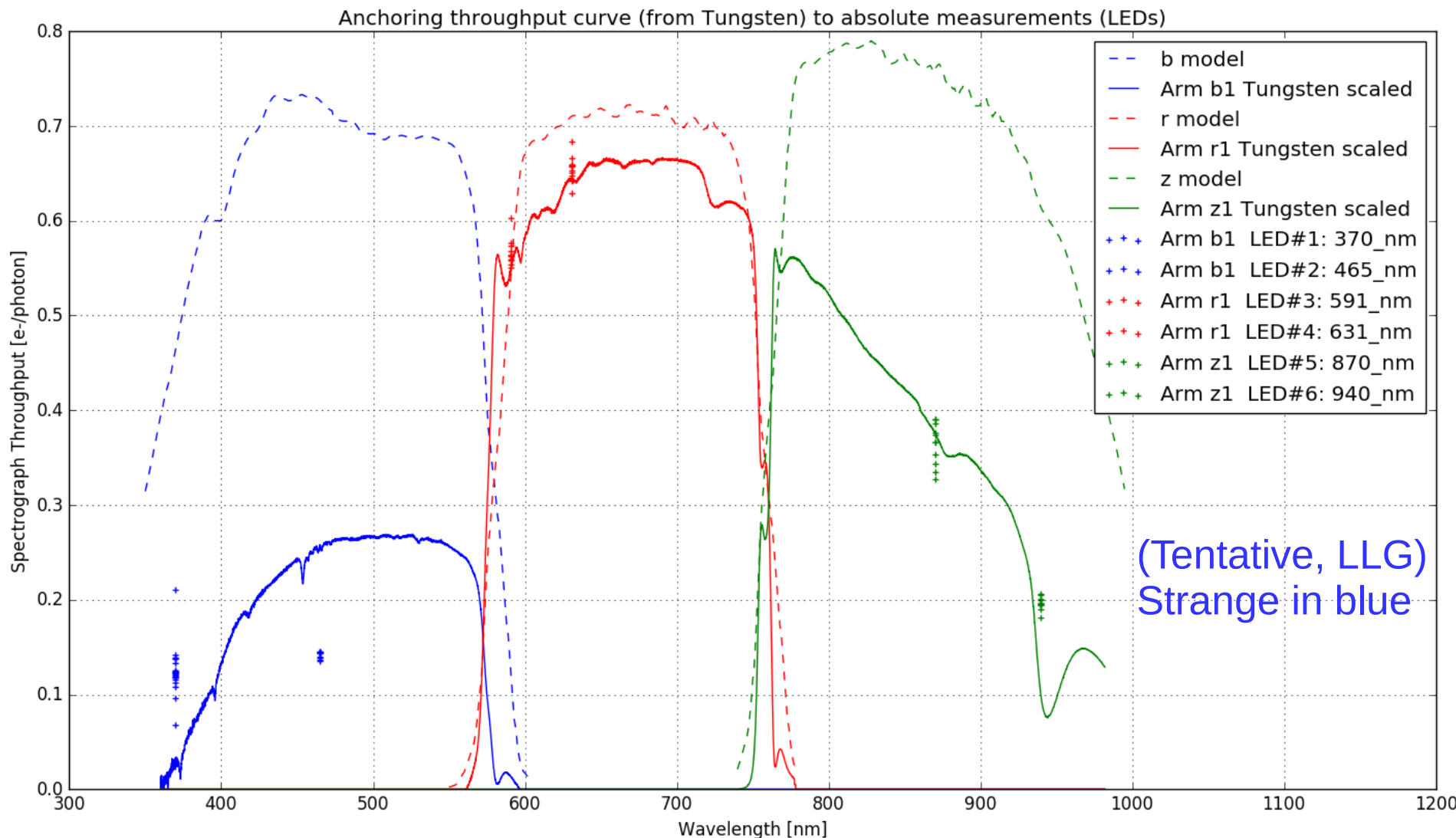

# With a model of the tungsten lamp spectrum

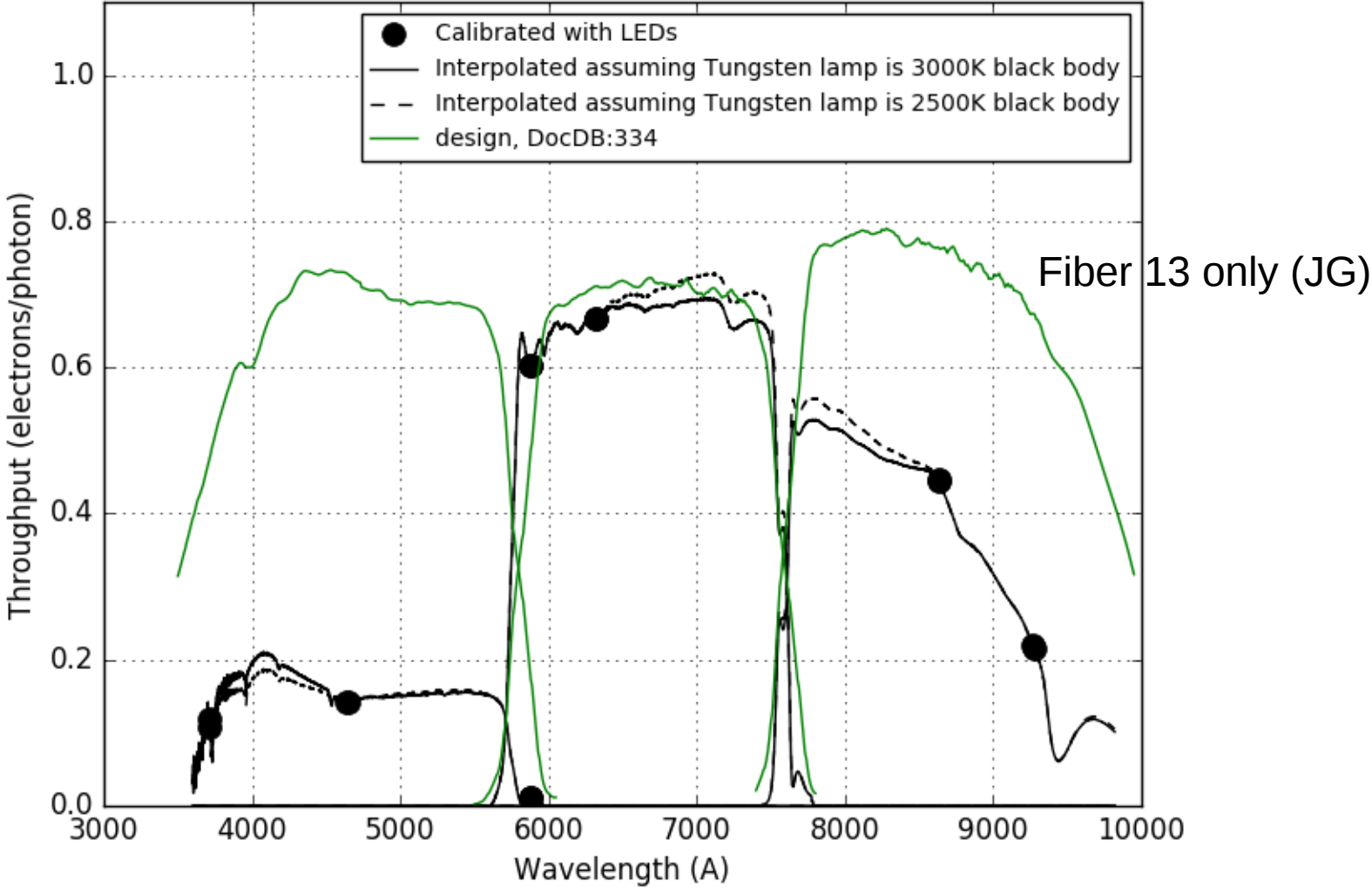

# Next: estimating the FRD from fiber beam scans

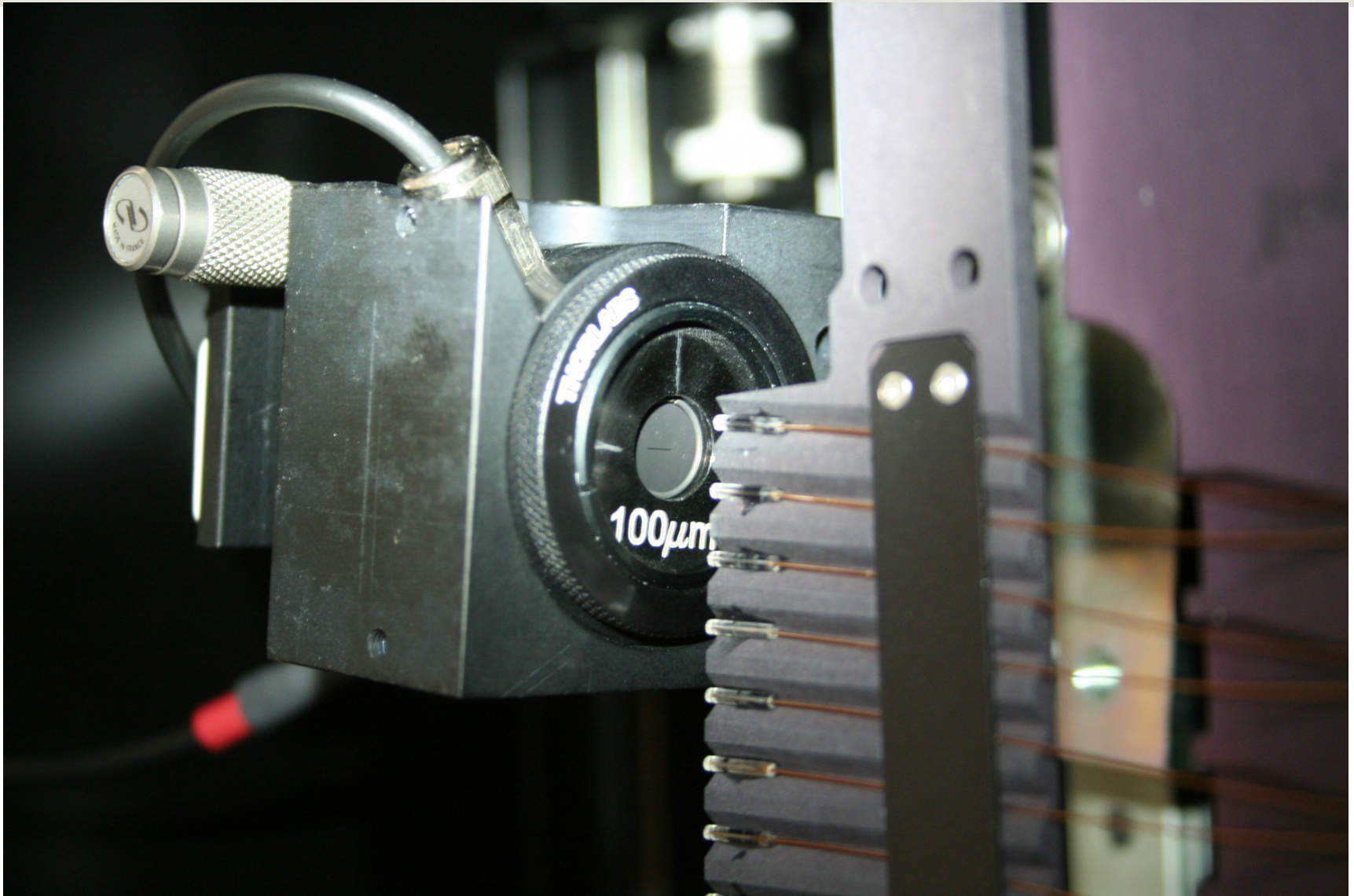



# Ongoing: estimating the FRD from fiber beam scans

**Beam central occultation (convolved by the 100 microns slit)**

- Using the 100 microns slit scans to model the fiber exit beam
- Estimating the Focal Ratio Degradation from this dataset
- Scan shapes vary from fiber to fiber
- (ongoing analysis LLG)

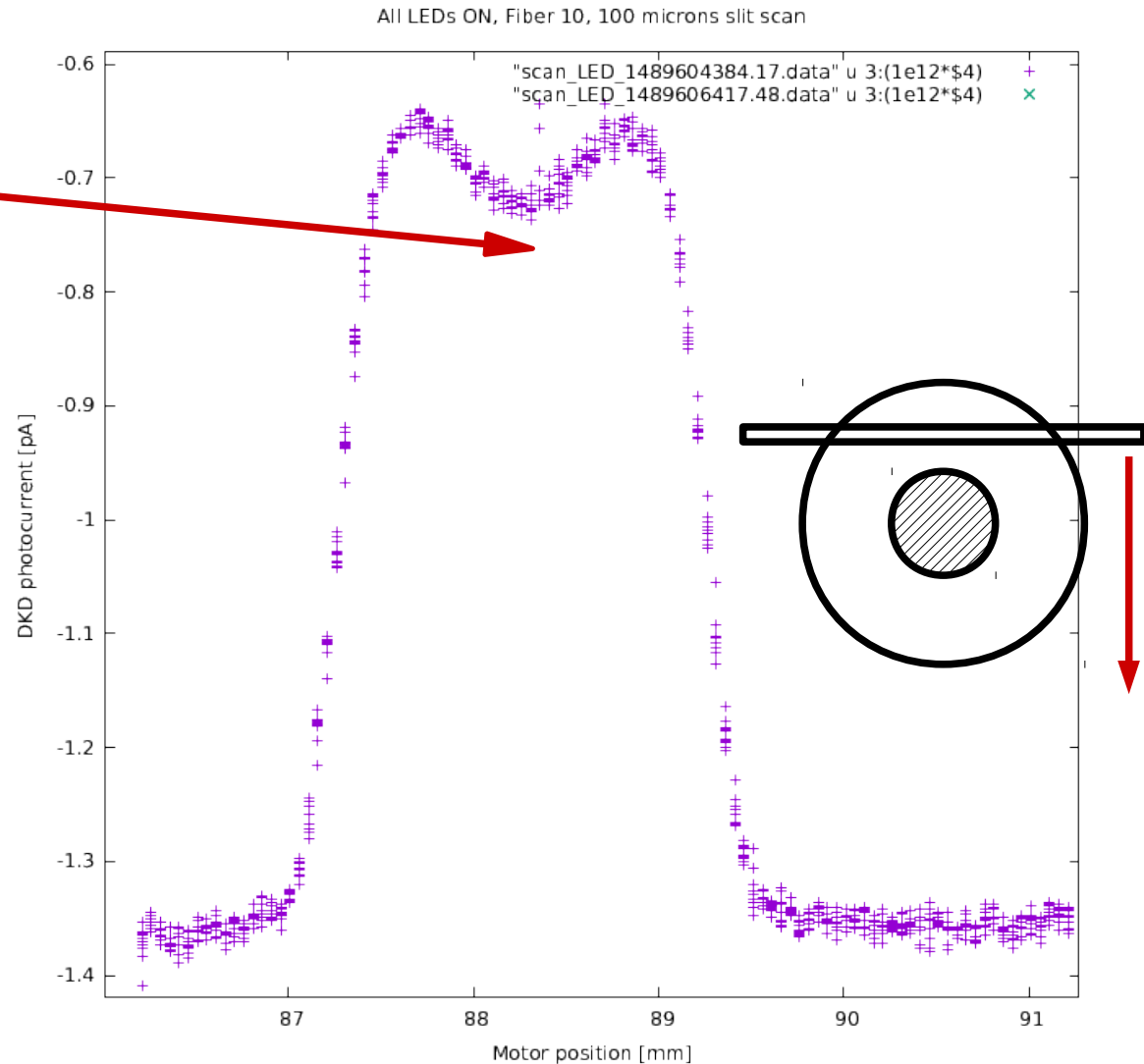

# Result: Very Low Throughput in B & Z(NIR) arms

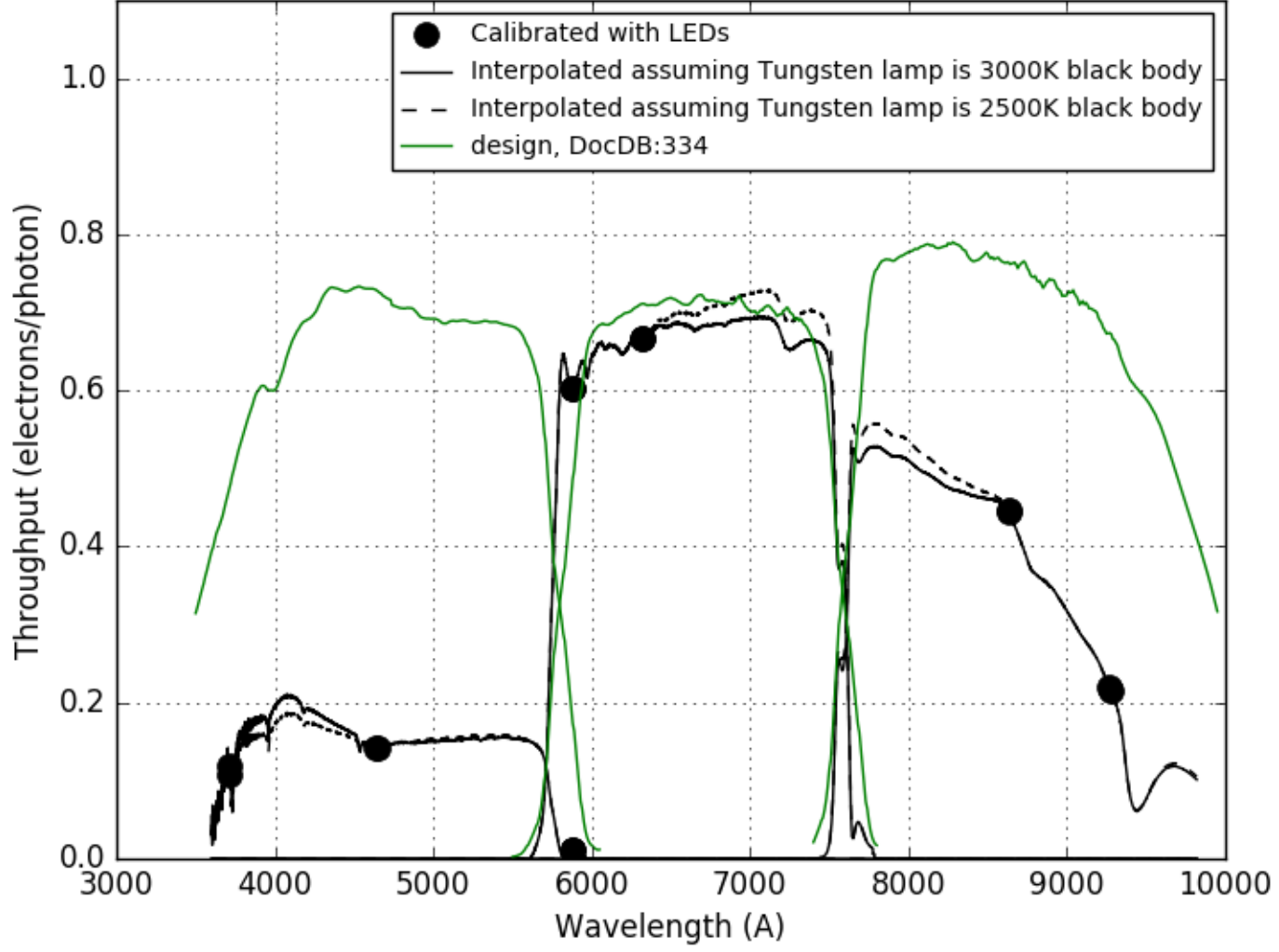

# Result: Very Low Throughput in B & Z(NIR) arms

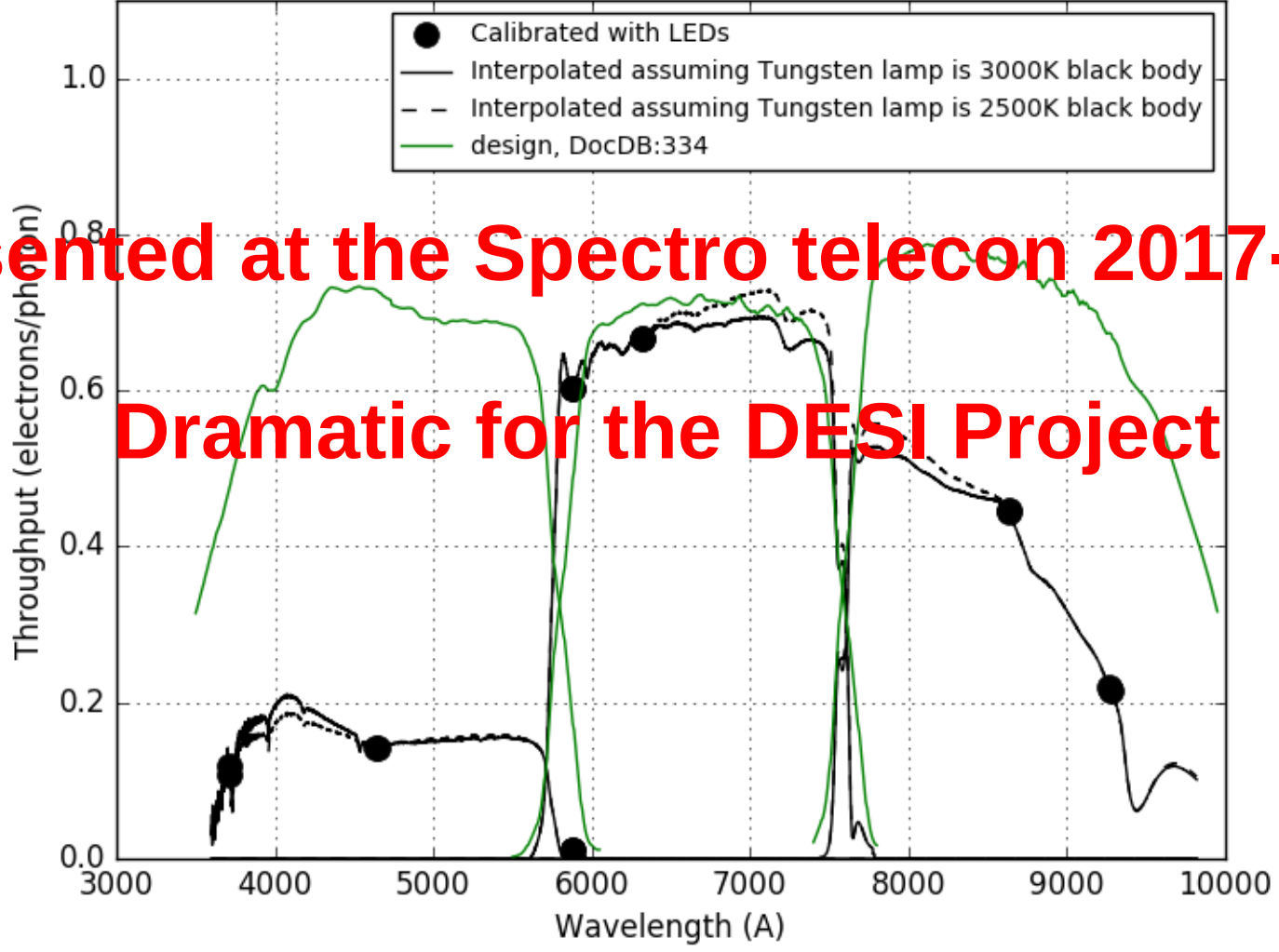

Presented at the Spectro telecon 2017-05-23  
Dramatic for the DESI Project



# Very Low Throughput in B and Z arms: why ?

- Possible culprit : the VPHG  
« Volume Phase Holographic gratings »
- Optimized to send most of the flux in order +1

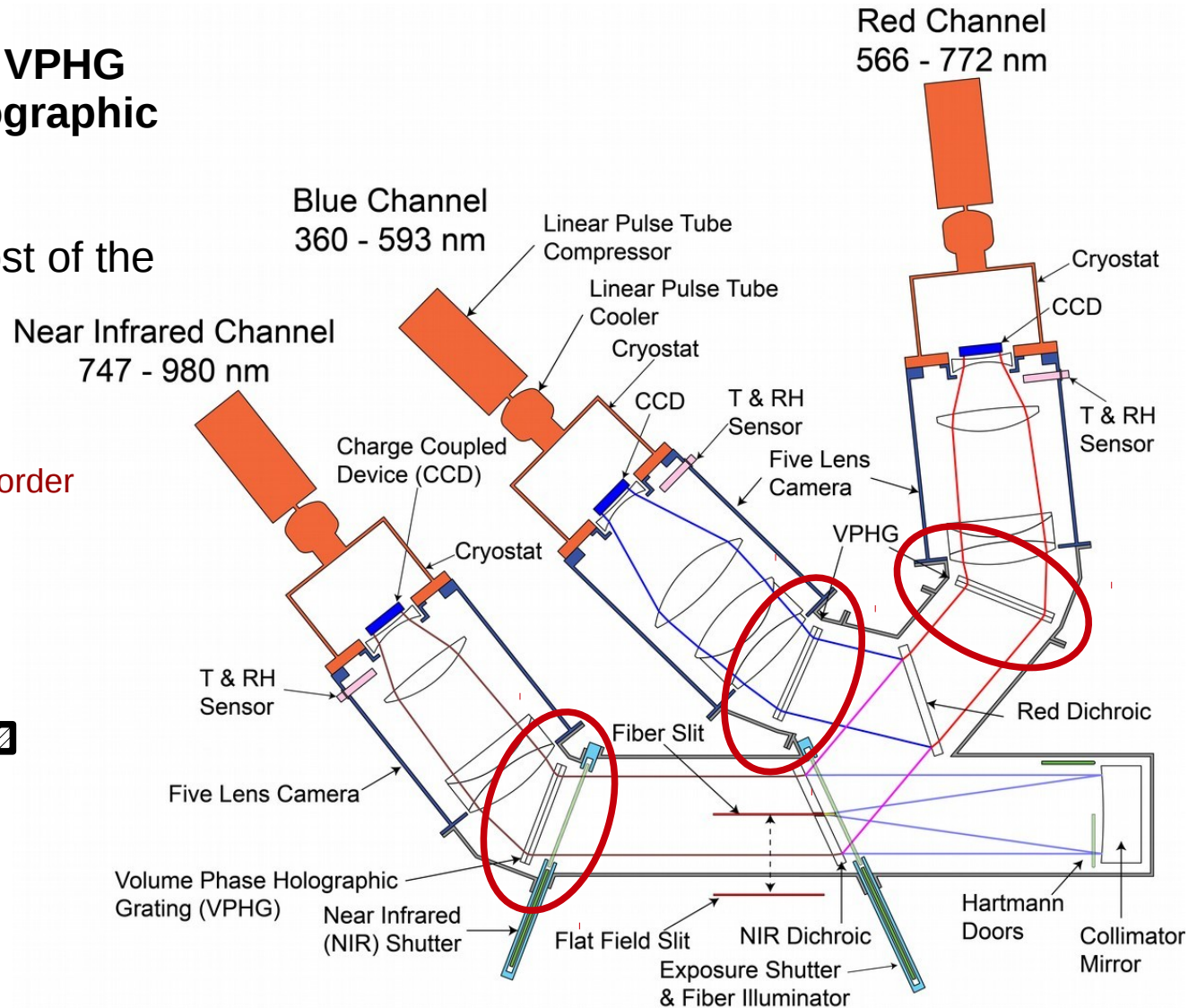
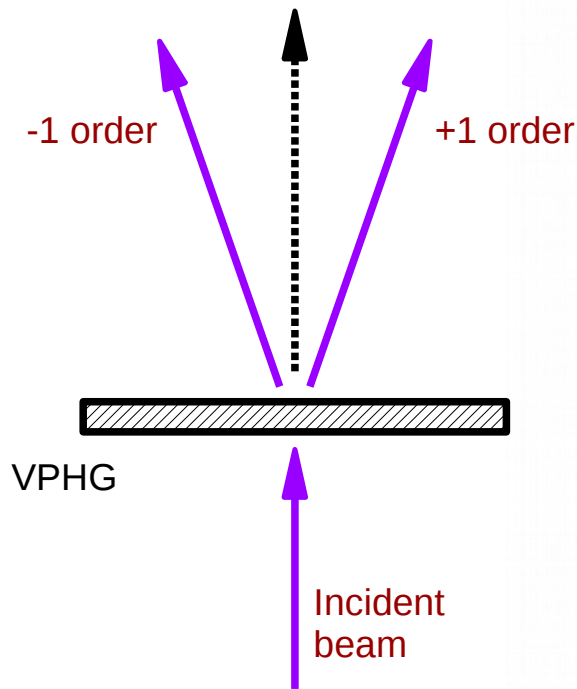



# Hypothesis: are some VPHG upside-down ?

- Possible culprit : the VPHG « Volume Phase Holographic gratings »
- Optimized to send most of the flux in order +1

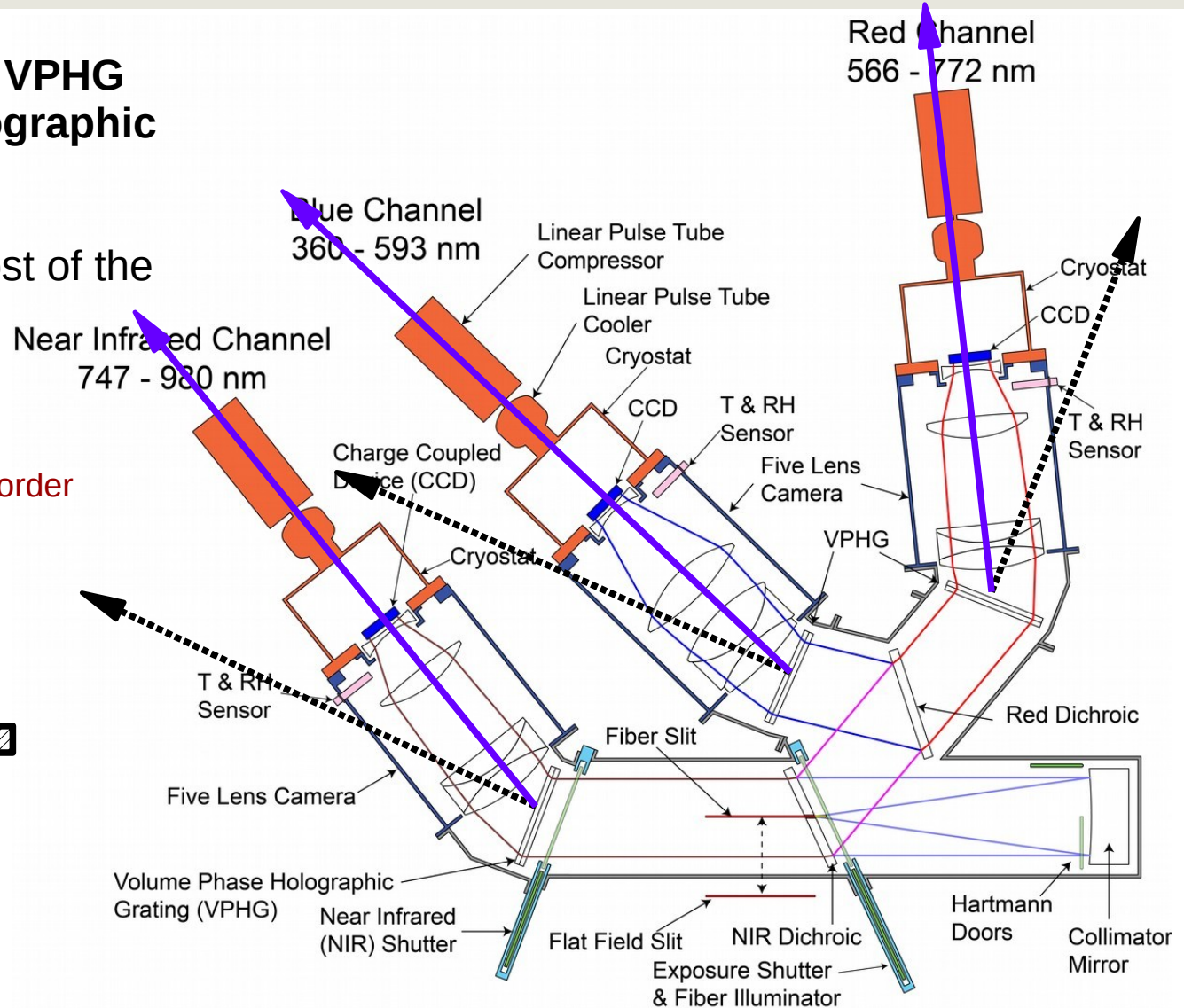
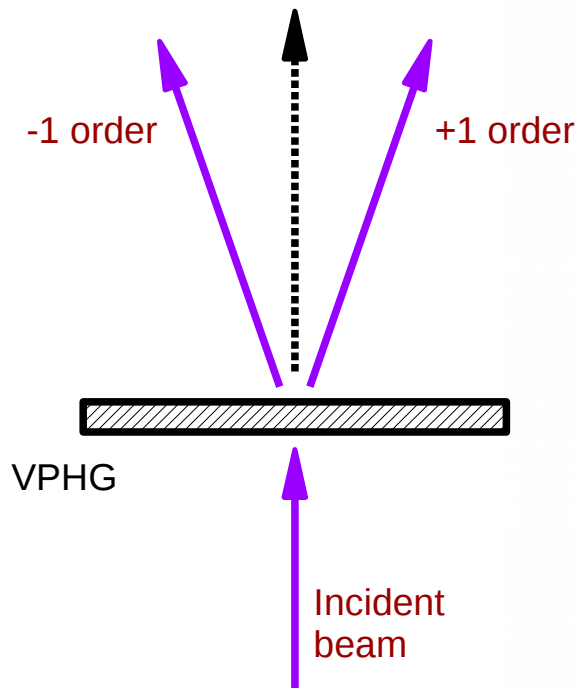

# VPHG were mounted upside-down in B & Z arms

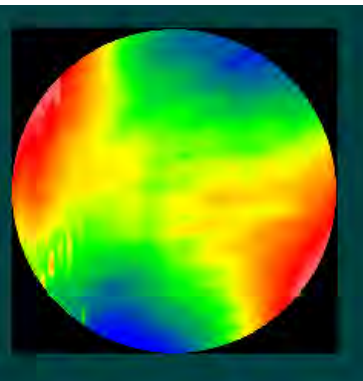

Blue arm VPHG  
(photos Eric T.)

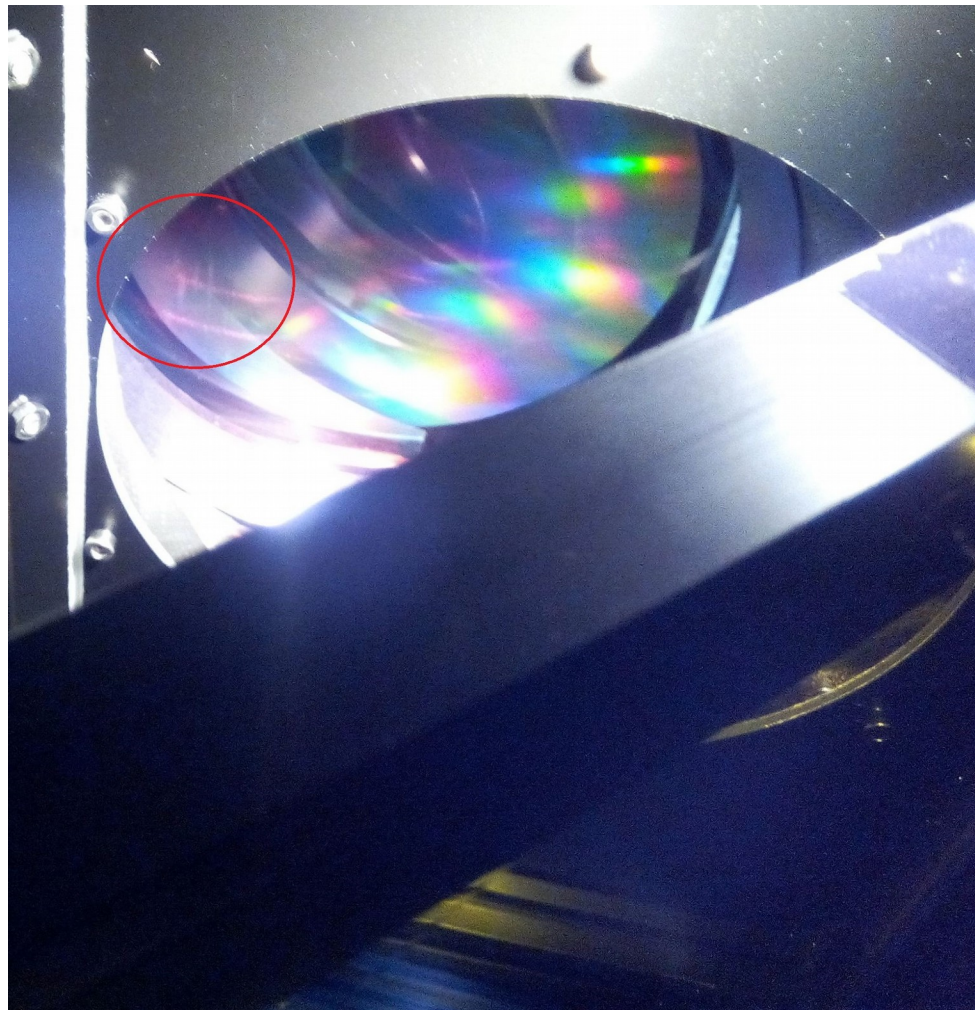
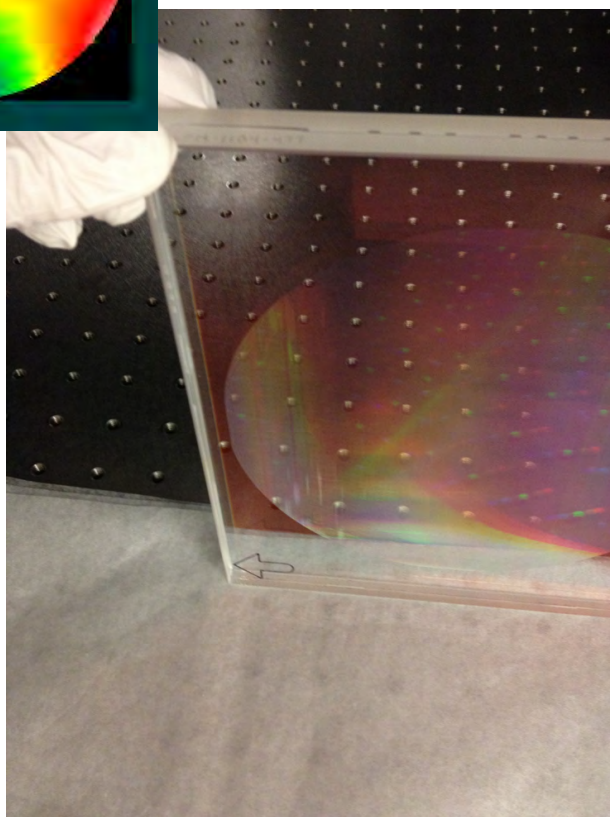



# VPHG were mounted upside-down in B & Z arms

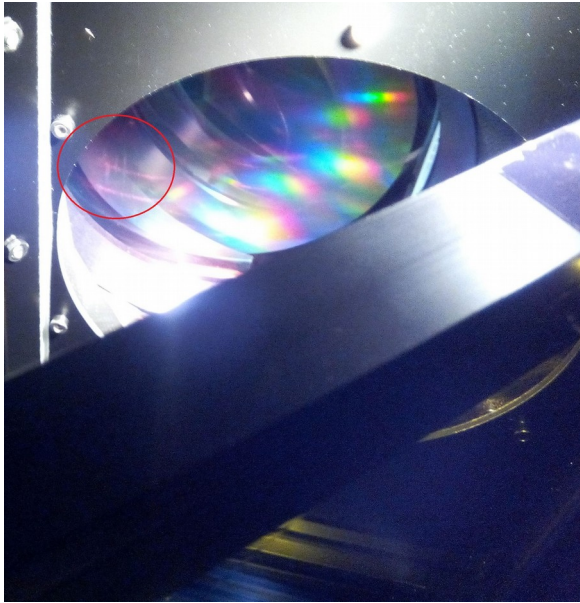

- **B & Z VPHG** were dismantled and **remounted in the right orientation** (June 2017).
- First checks with Tungsten lamp show that the throughput has been improved. July campaign cancelled (shutter problems)

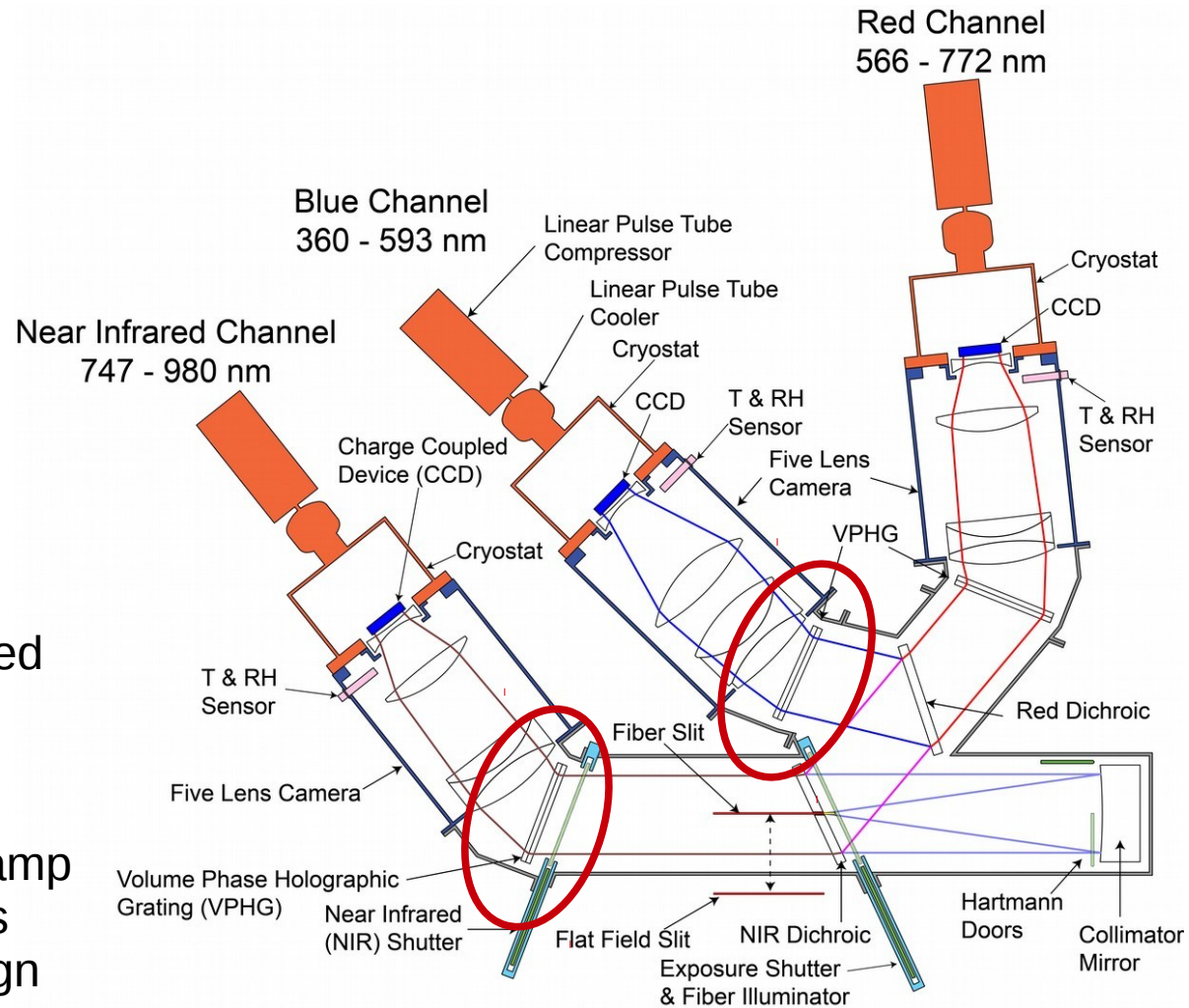

# Conclusions et perspectives

- ◆ Système de mesure de la transmission des spectrographes DESI **conçu, construit, testé au LPNHE, et installé sur le banc AMU** chez Winlight.
- ◆ Mesures effectuées sur le spectro EM#1 : **transmission trop faible en B et en Z.**
- ◆ A permis de corriger une **grave erreur de montage de l'optique pour ce spectrographe et pour les 9 suivants.** Validation de l'importance de cette mesure sur tous les spectrographes.
- ◆ Prochaine campagne de mesure en novembre-décembre sur le spectrographe SM#1 (EM#1 *refurbished*).
- ◆ Notes techniques DESI, et éventuelle publication sur la méthode.

