

# Throughput Measurement Status

Laurent Le Guillou (UPMC/LPNHE)  
Julien Guy (IN2P3/LPNHE)

*Spectrograph Telecon*  
2017-05-23

LPNHE : Julien Coridian, Patrick Ghislain, Julien Guy, Sonia Karkar, Laurent Le Guillou, Yann Orain, Philippe Repain, Eduardo Sepulveda  
AMU : Pierre-Eric Blanc, Sandrine Perruchot, Xavier Regal, Samuel Ronayette



# Talk outline

- **Throughput Measurement: Principles**
- **Flux Calibration Device for the Test Fiber Slit**
- **Measurement Campaigns**
- **Data analysis (Preliminary)**
  - Flux measurements with the calibrated photodiode (DKD)
  - LED spectra with DESI spectrograph: reduction, extraction
  - Exposure time: shutter time correction
  - Gain correction: Gain of the CCD amplifiers
  - First direct throughput estimate (without a throughput model)
  - Combining with a model derived from Tungstene lamp exposures
- **Next steps : Focal Ratio Degradation (FRD) estimate**



# The DESI spectrograph

- 10 identical spectrographs
- 10 x 500 fibers
- 3 arms :  
NIR, Red, Blue

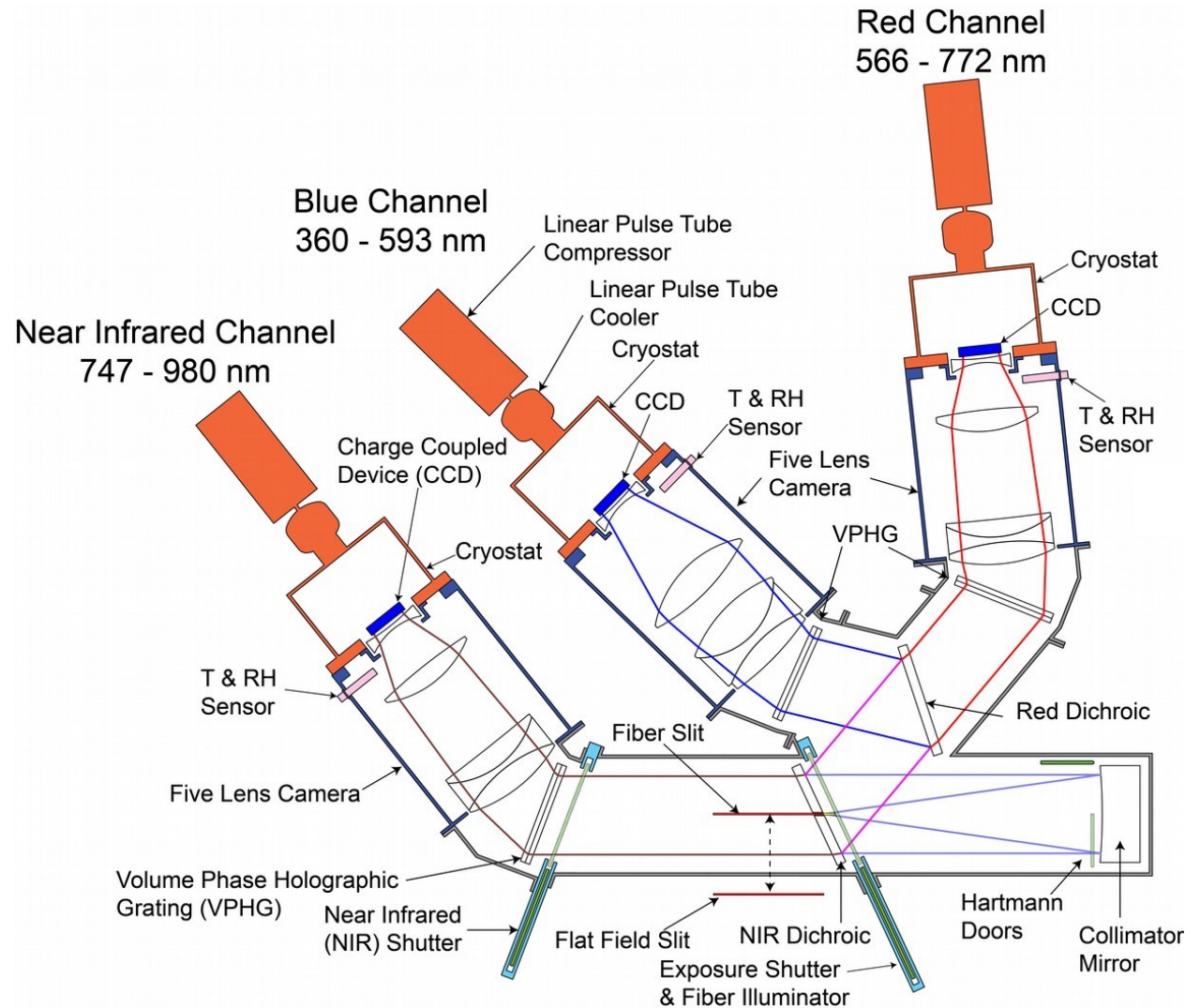

# The DESI spectrograph

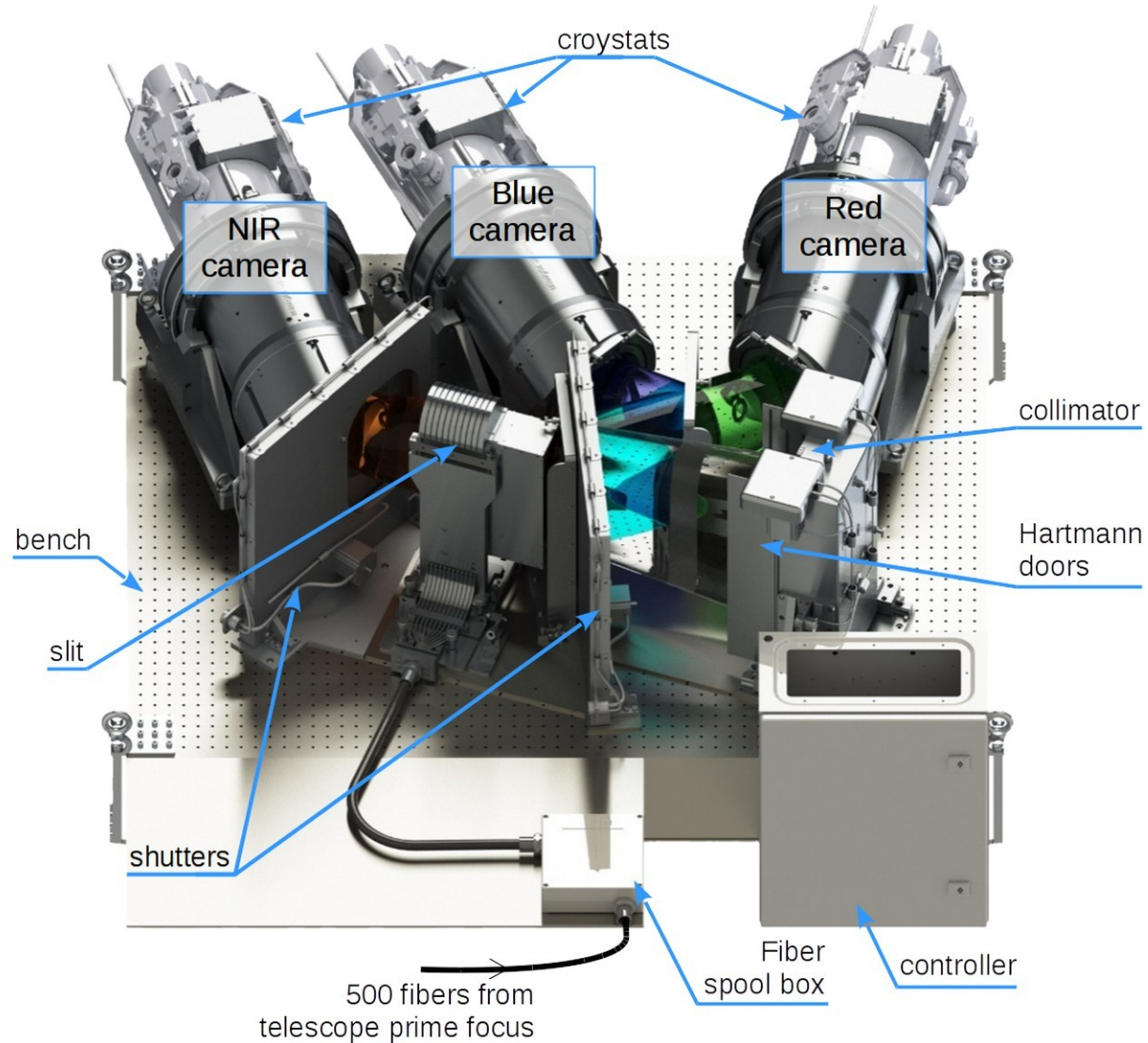

# Illumination Testbench (AMU@Winlight)

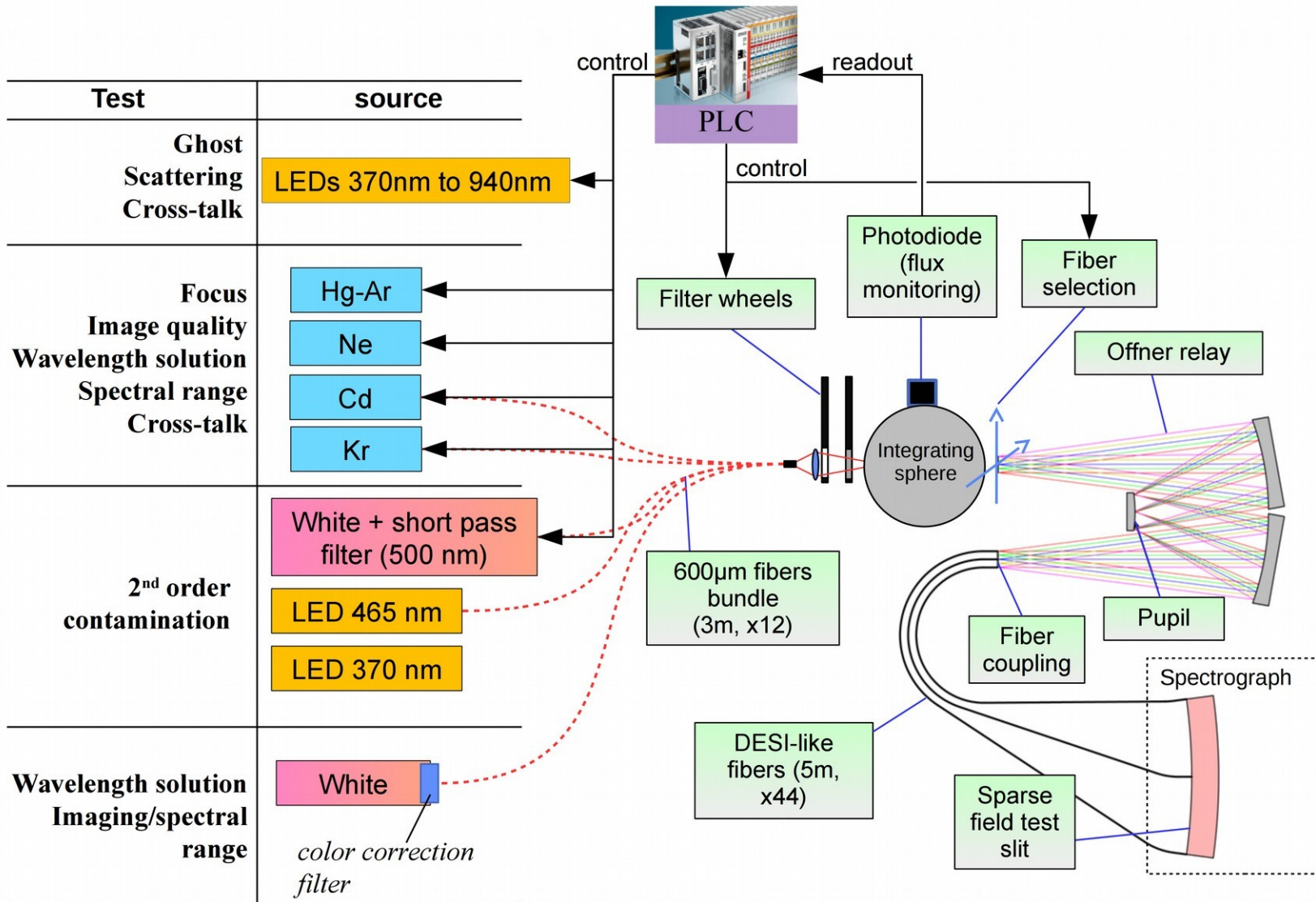

# Sparse fiber slit(s): allows single fiber illumination

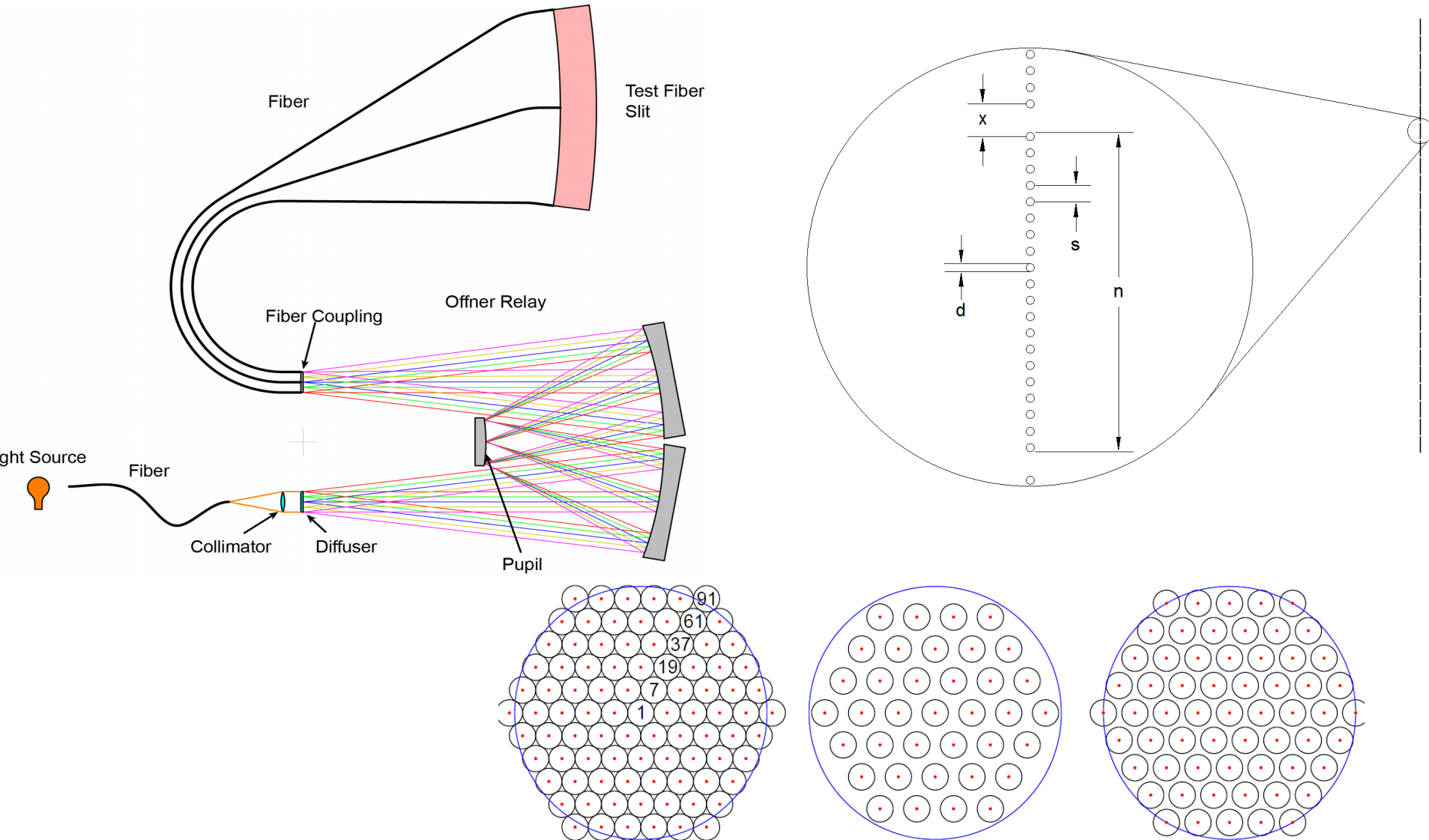

# Fiber slit(s): “sparse fiber slit”

- 21 well separated fibers
- May be illuminated individually (AMU bench)

Fiber :  $f/3.57$   
Angle  $\theta \sim 8^\circ$

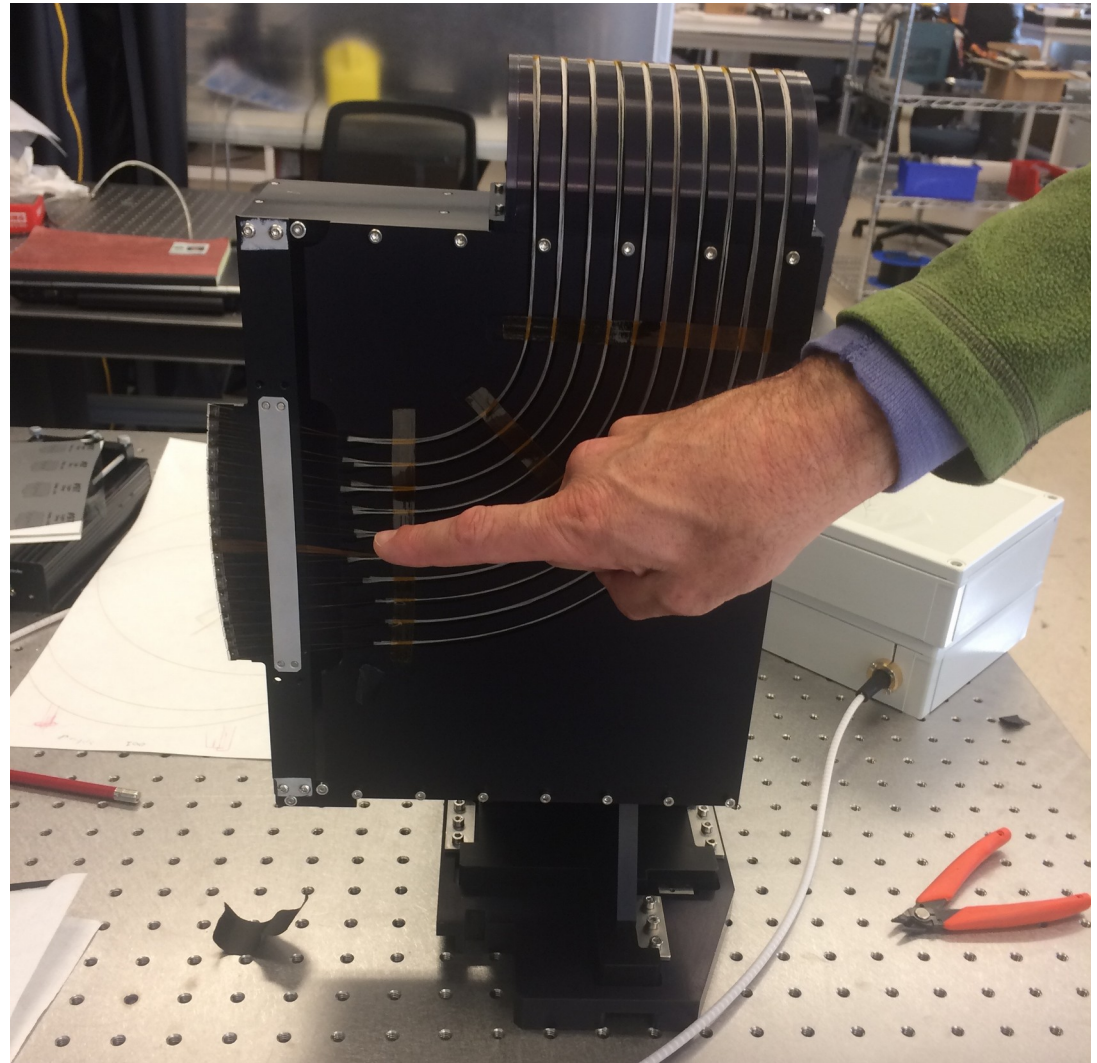

# Throughput measurement principles

- Measurement to be done during **slit removal/reinstall** repeatability test (limited overhead)
- **Calibration of the total flux** at the exit of each fiber of the sparse fiber slit
- **Proposed Procedure** : for the same illumination setups (LEDs)
  - **(1) Sparse Test Slit outside of the spectrograph, in front of our device** : flux (in the same illumination conditions) measured by our calibrated photodiode, for each LED / fiber ;
  - **(2) Sparse Test Slit inside the spectrograph** : integrated flux measured on the CCD for the 3 arms of the spectrograph for each LED / fiber ;
  - **Ratio (1)/(2)** gives **throughput** (from fiber exit to the CCD included)





# Mechanical design

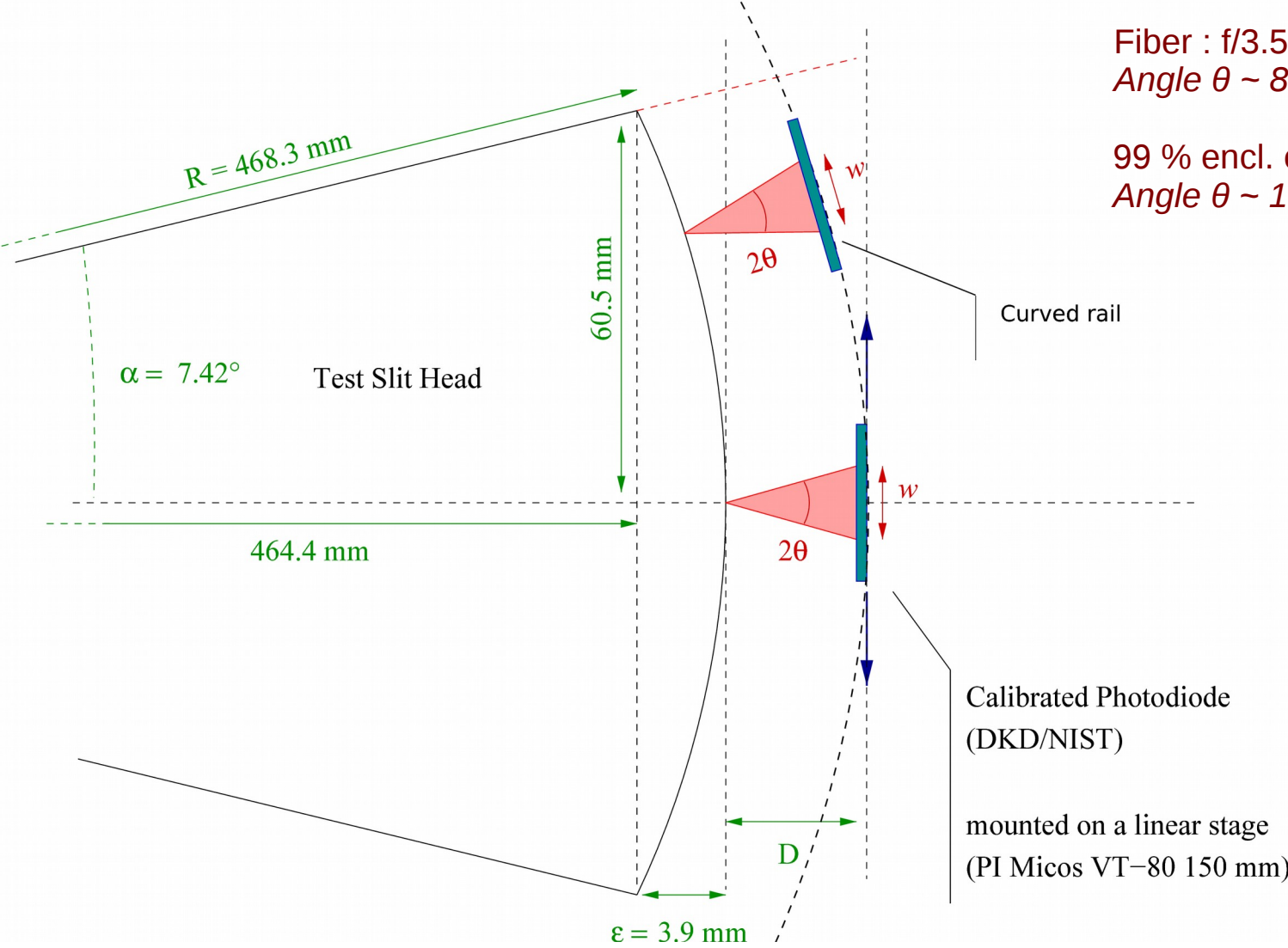

Fiber : f/3.57  
 Angle  $\theta \sim 8^\circ$

99 % encl. energy : f/2.5  
 Angle  $\theta \sim 11.3^\circ$

Curved rail

$\alpha = 7.42^\circ$  Test Slit Head

464.4 mm

60.5 mm

$2\theta$

$2\theta$

w

w

Calibrated Photodiode  
 (DKD/NIST)

mounted on a linear stage  
 (PI Micos VT-80 150 mm)

D

$\epsilon = 3.9$  mm



# Throughput measurement device

Motorized  
linear stage  
Pi/MICOS  
<0.4  $\mu\text{m}$  accuracy

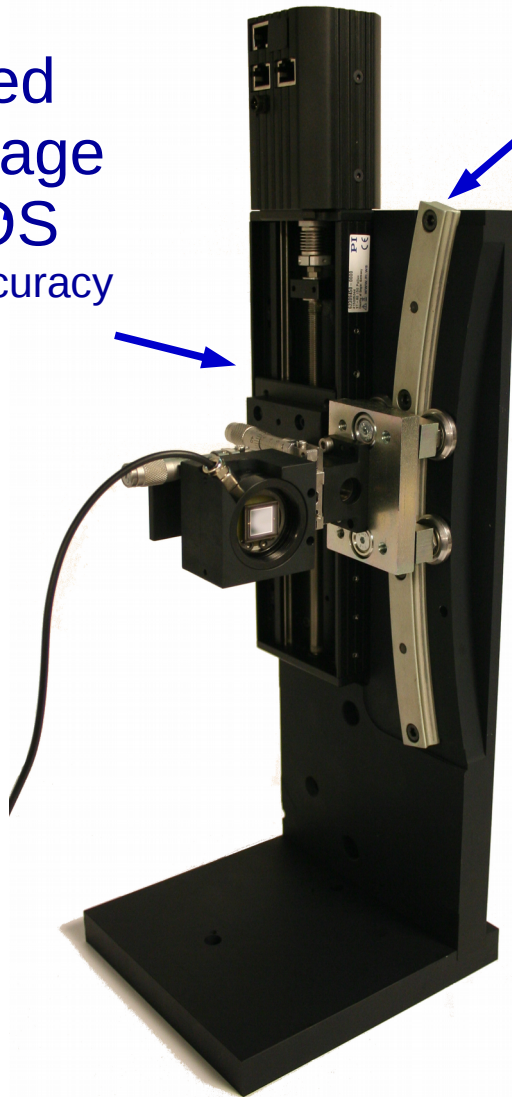

Curved rail  
(radius 500 mm)

Calibrated  
Photodiode  
10x10 mm<sup>2</sup>

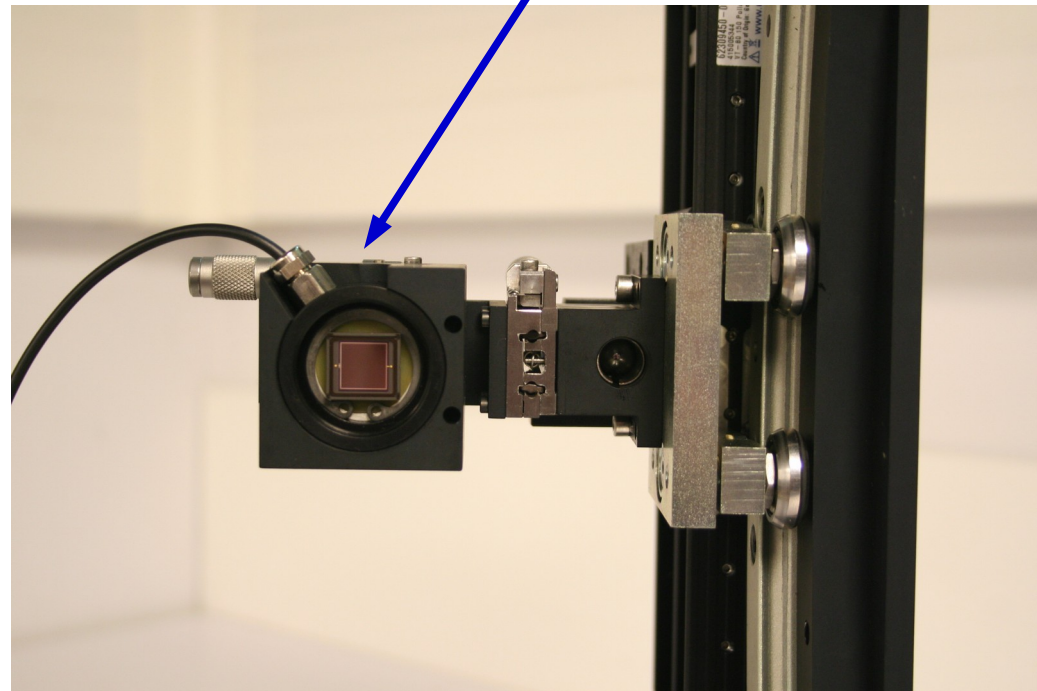

# Throughput measurement device

Dedicated  
Dark Box

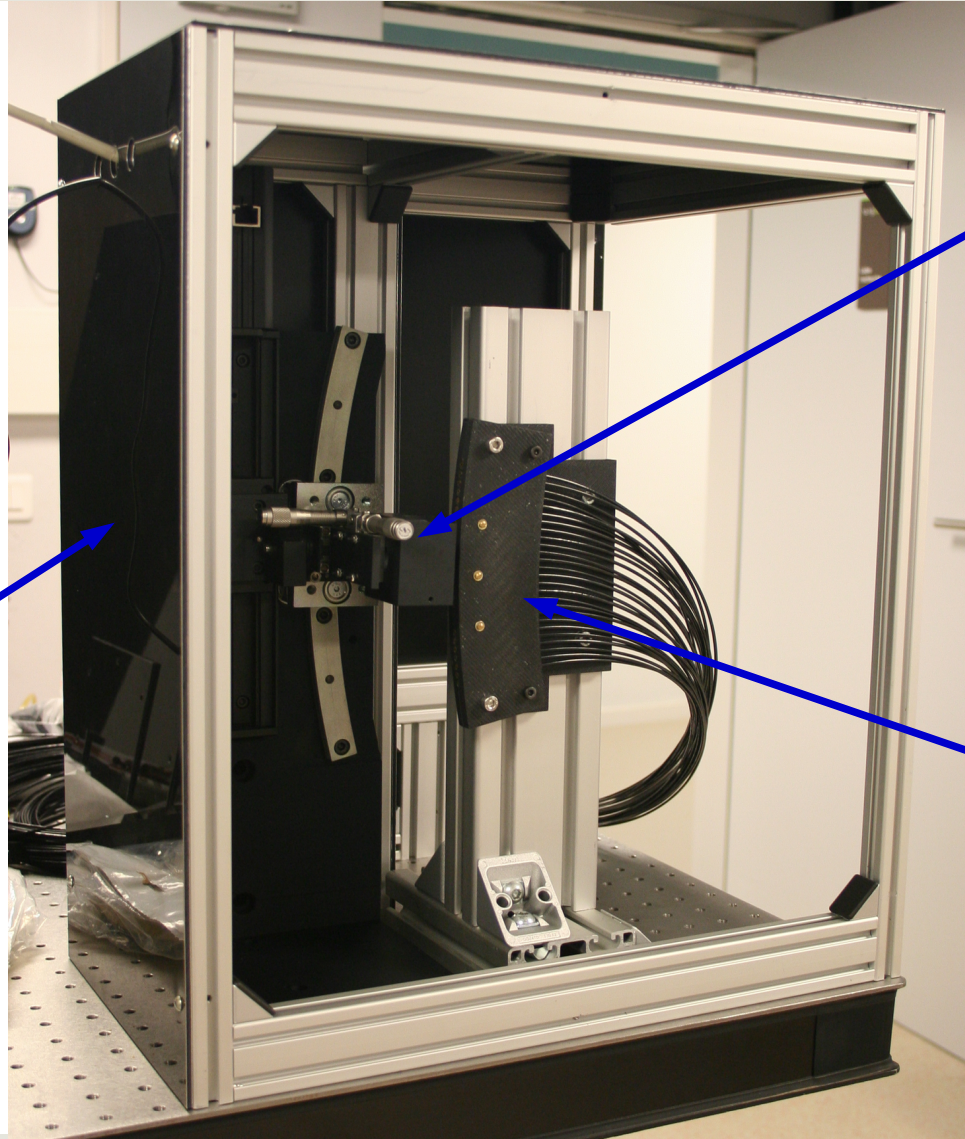

Calibrated  
Photodiode

Mock test slit  
3D printed  
Old fiber bundle  
(DESY, H1)



# Calibrated Photodiode

- MD-37-SU100 **calibrated (spectral responsivity [A/W])**
  - **DKD (DE) certified absolute calibration**
  - 2 % on 250 – 1100 nm.
- Size : 10x10 = 100 mm<sup>2</sup>
- Photodiode current readout : picoammeter  
**Keithley 6514**, or better **6482** (2 channels), (fA)
- **Simultaneous monitoring of :**
  - Light flux in the integrating sphere
  - Light flux exiting the fiber→ Control of the **illumination stability**



# Illumination Testbench (AMU)

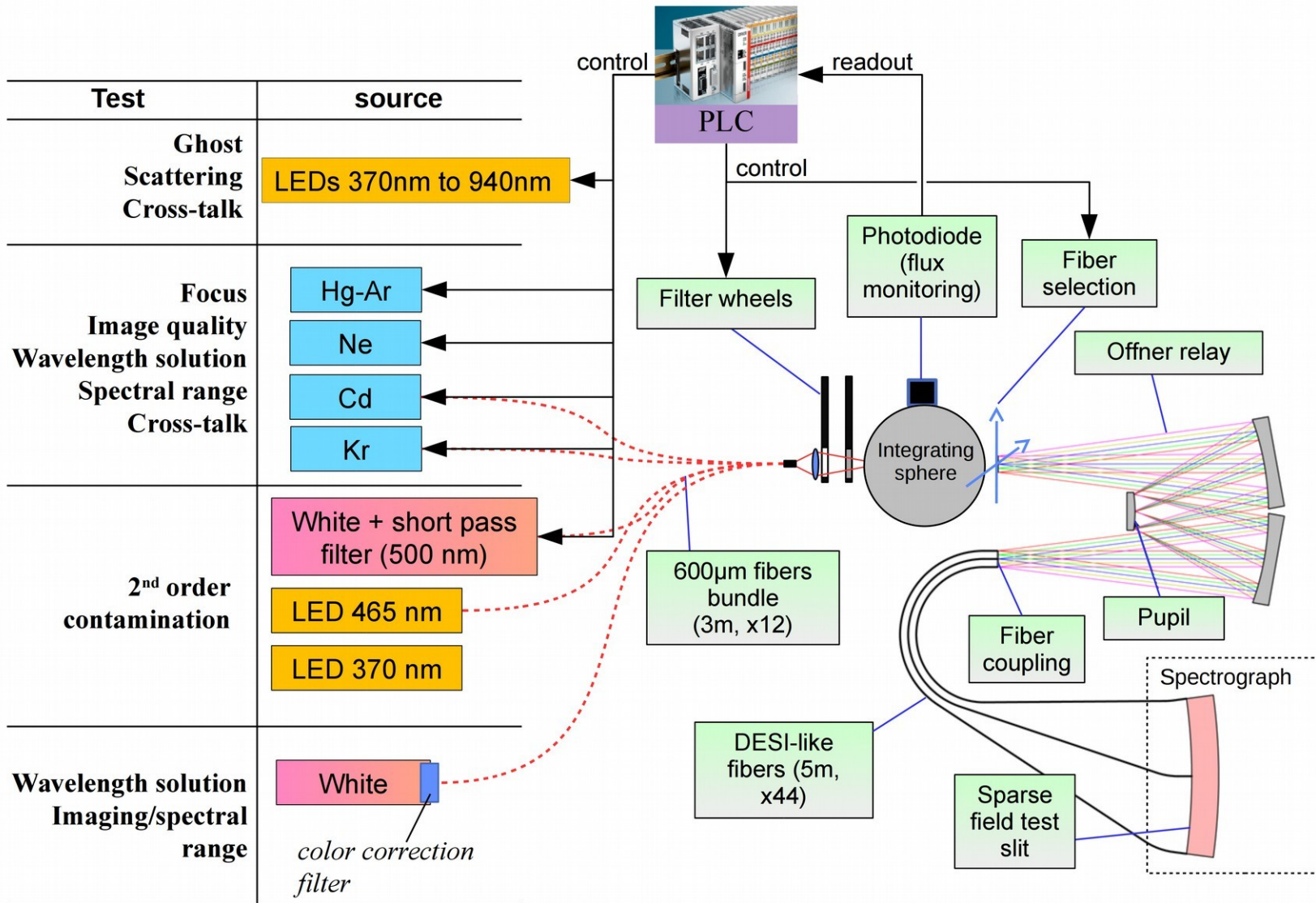

# Illumination Testbench (AMU)

**LED : bright enough  
Compact spectrum !**

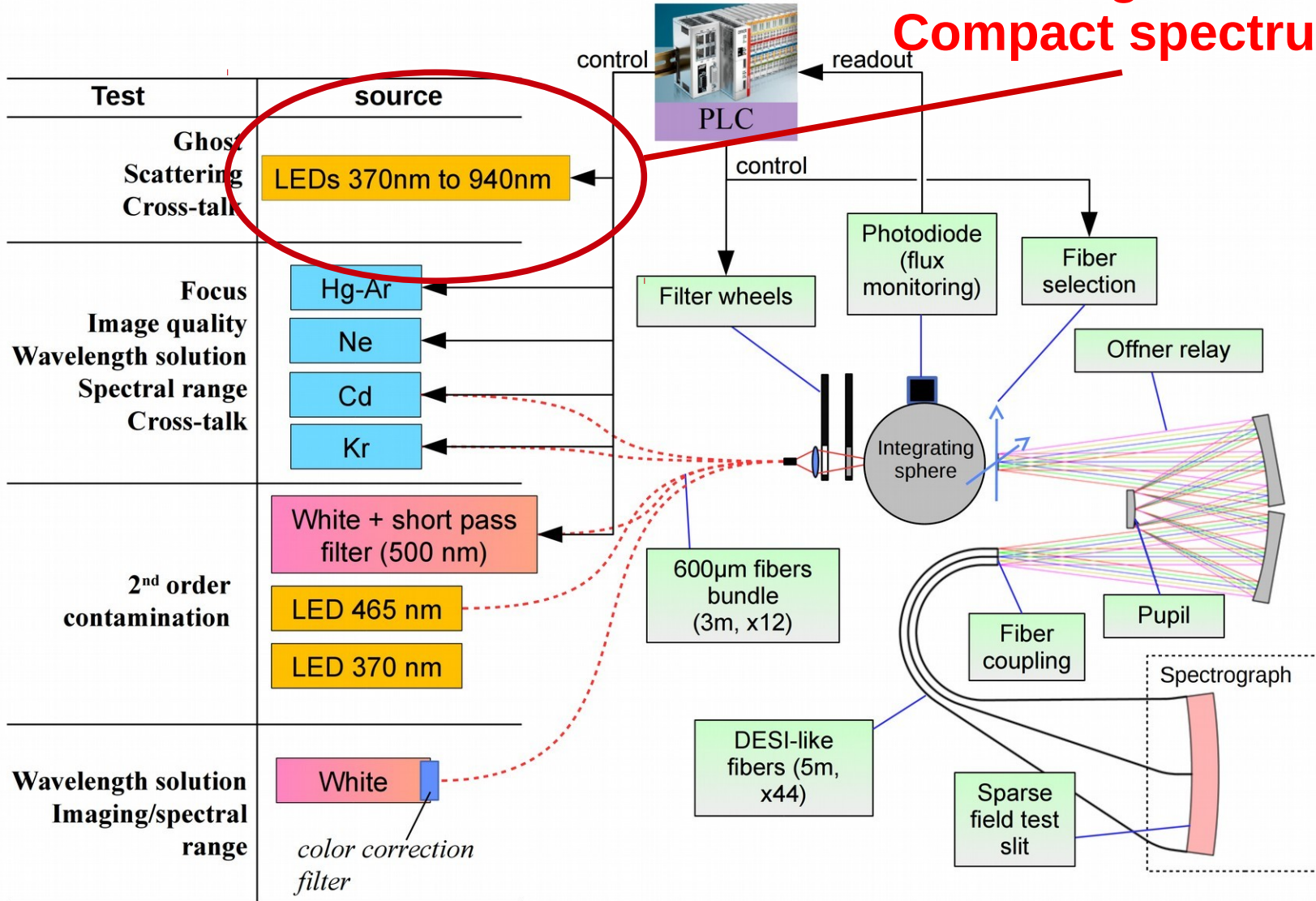

# LED spectra: compact spectra

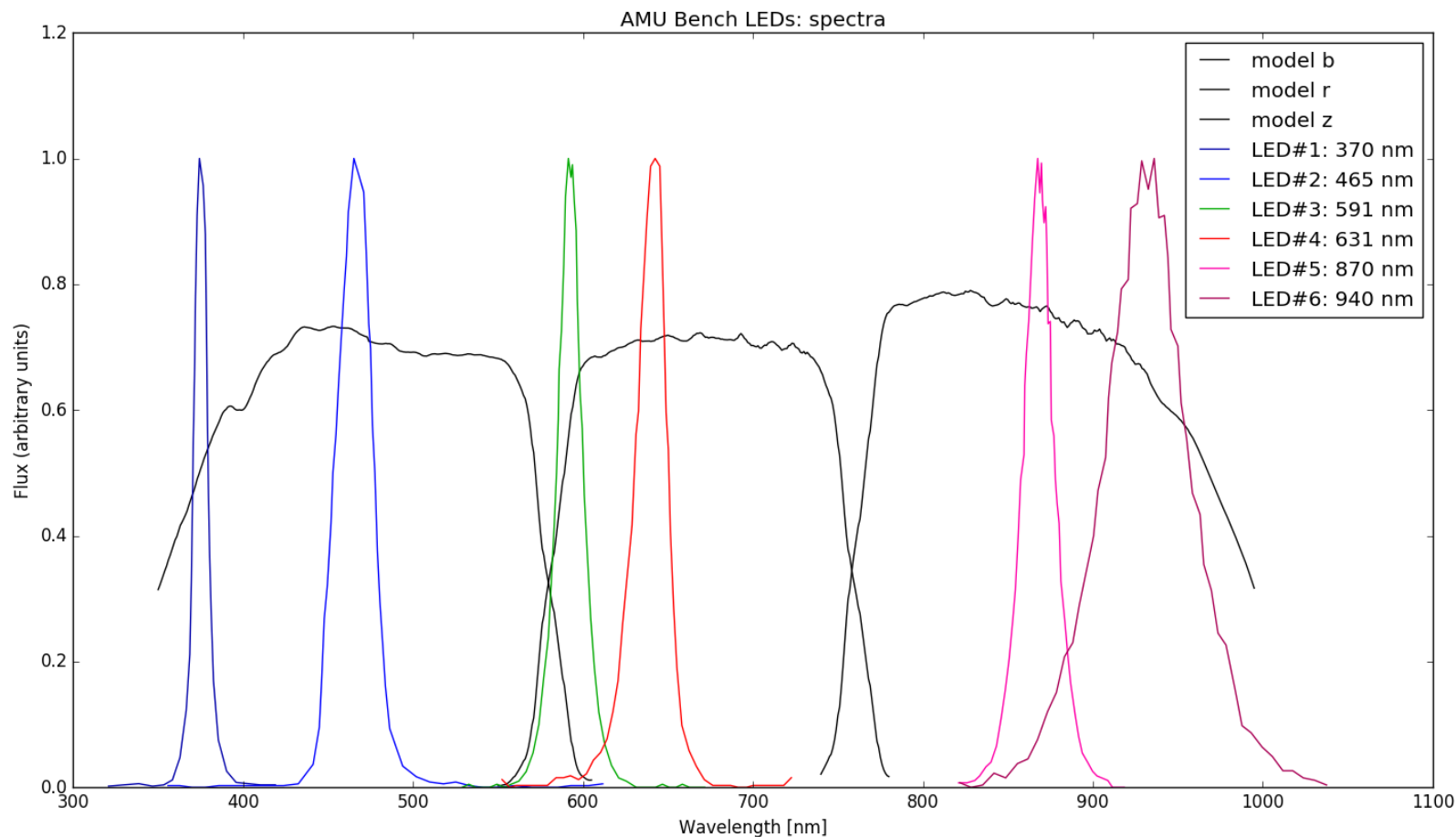

# Photodiode Calibration (DKD certified)

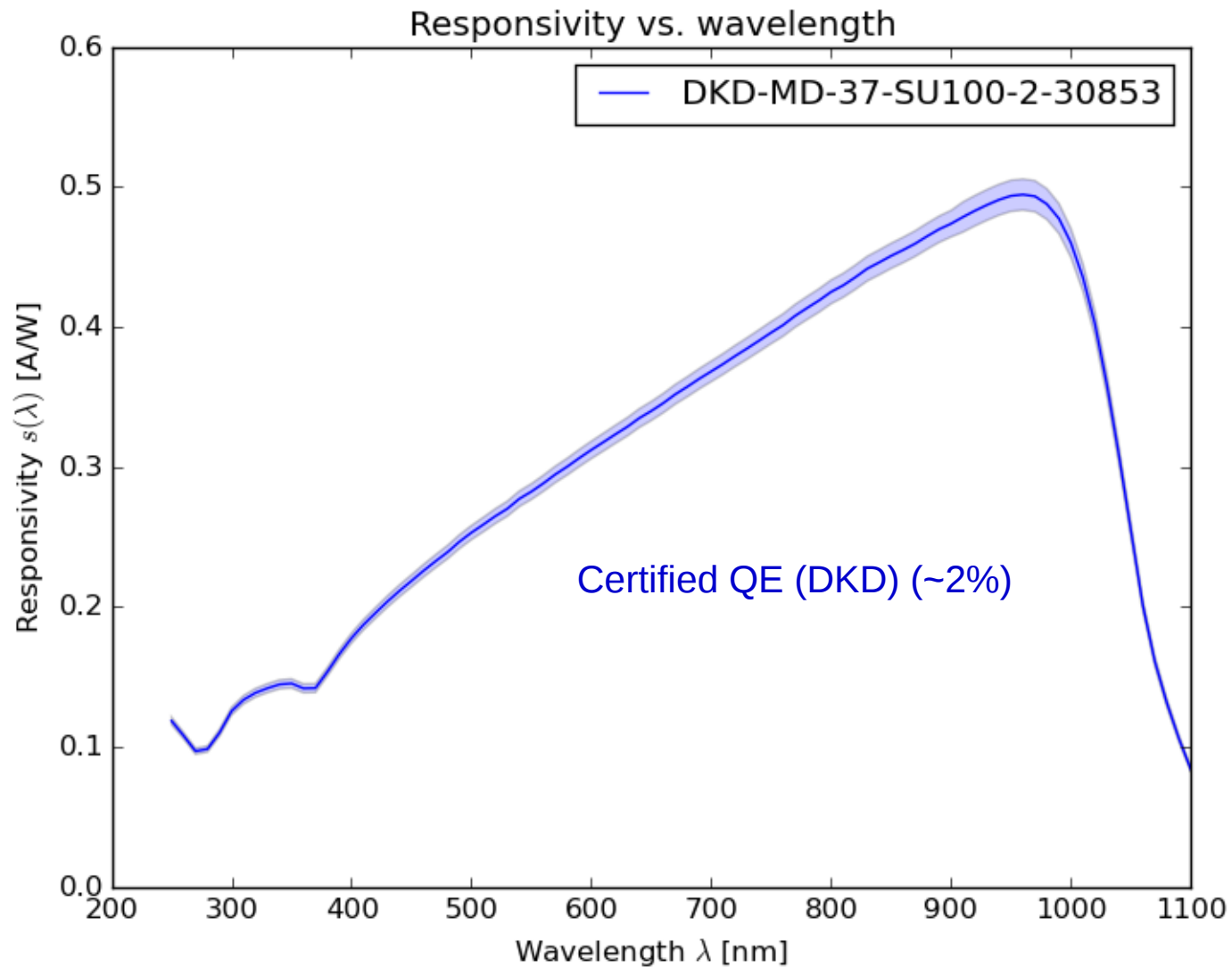



# Photodiode Calibration (DKD certified)

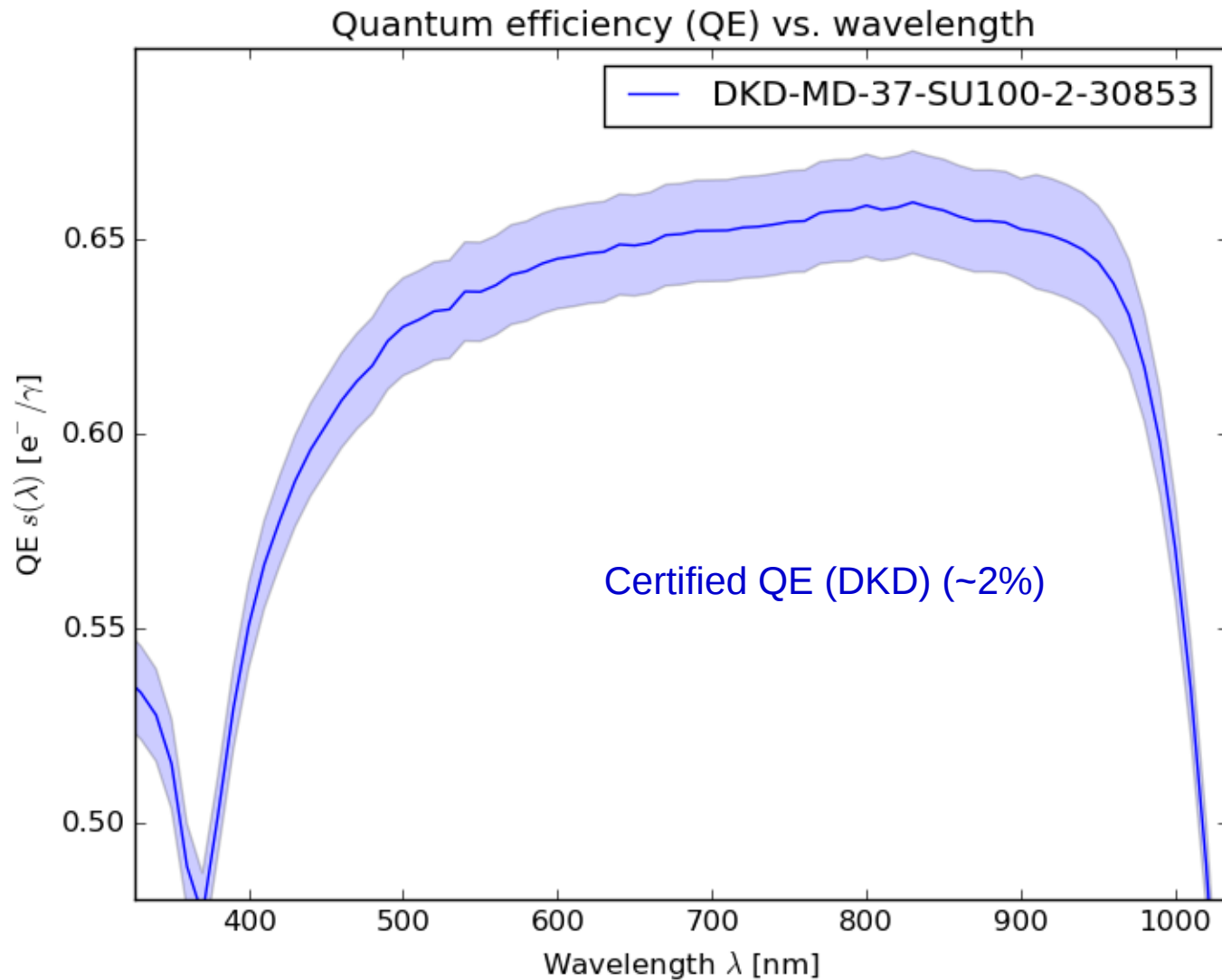

# Photodiode Calibration & checks at LPNHE

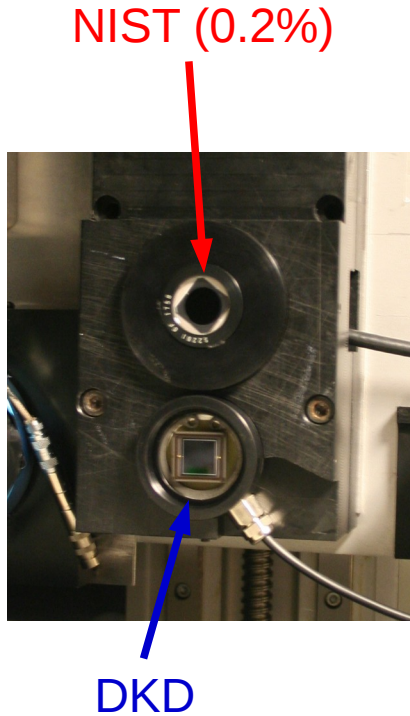

See DESI-2635 (LLG)

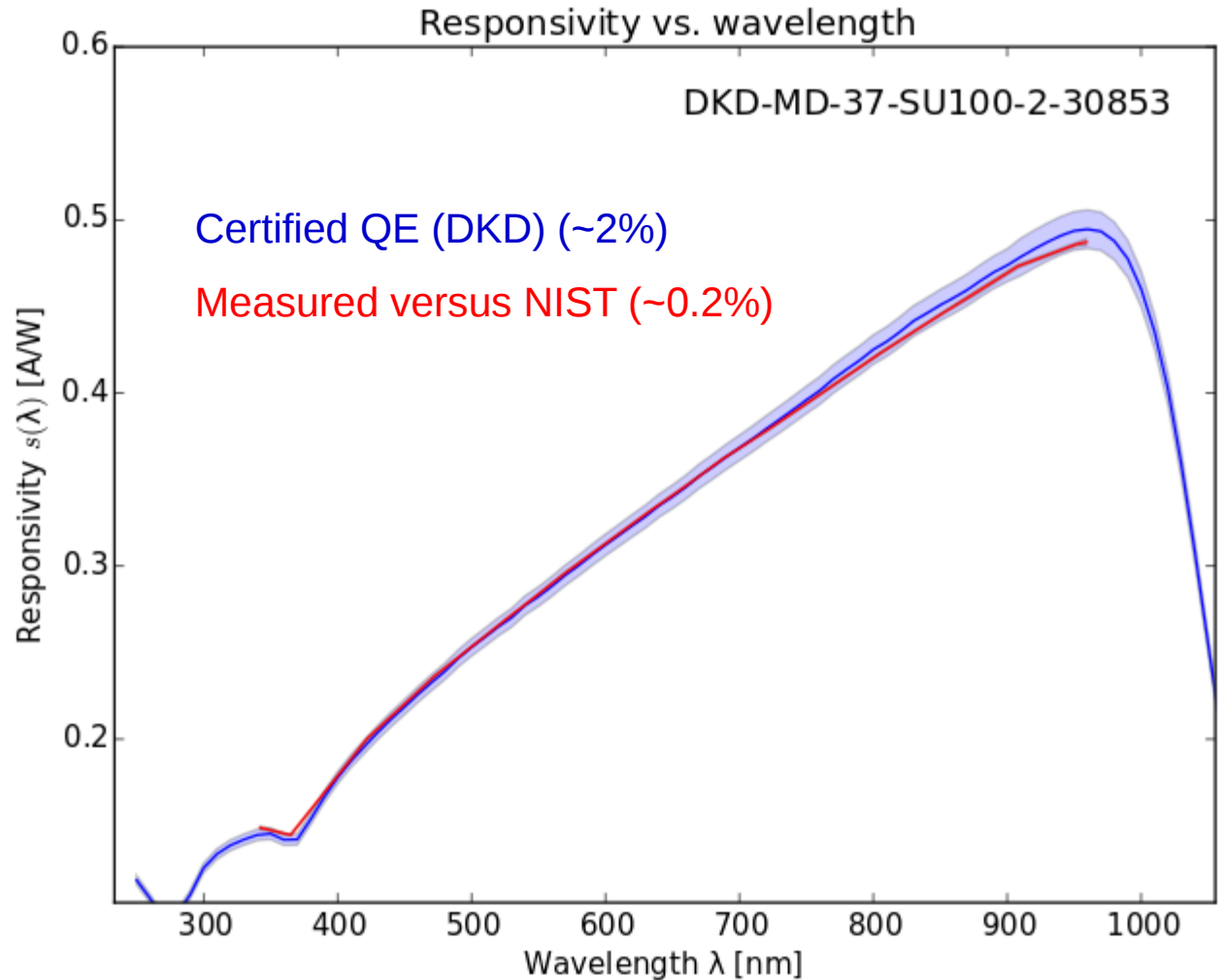

# Photodiode Calibration & checks at LPNHE

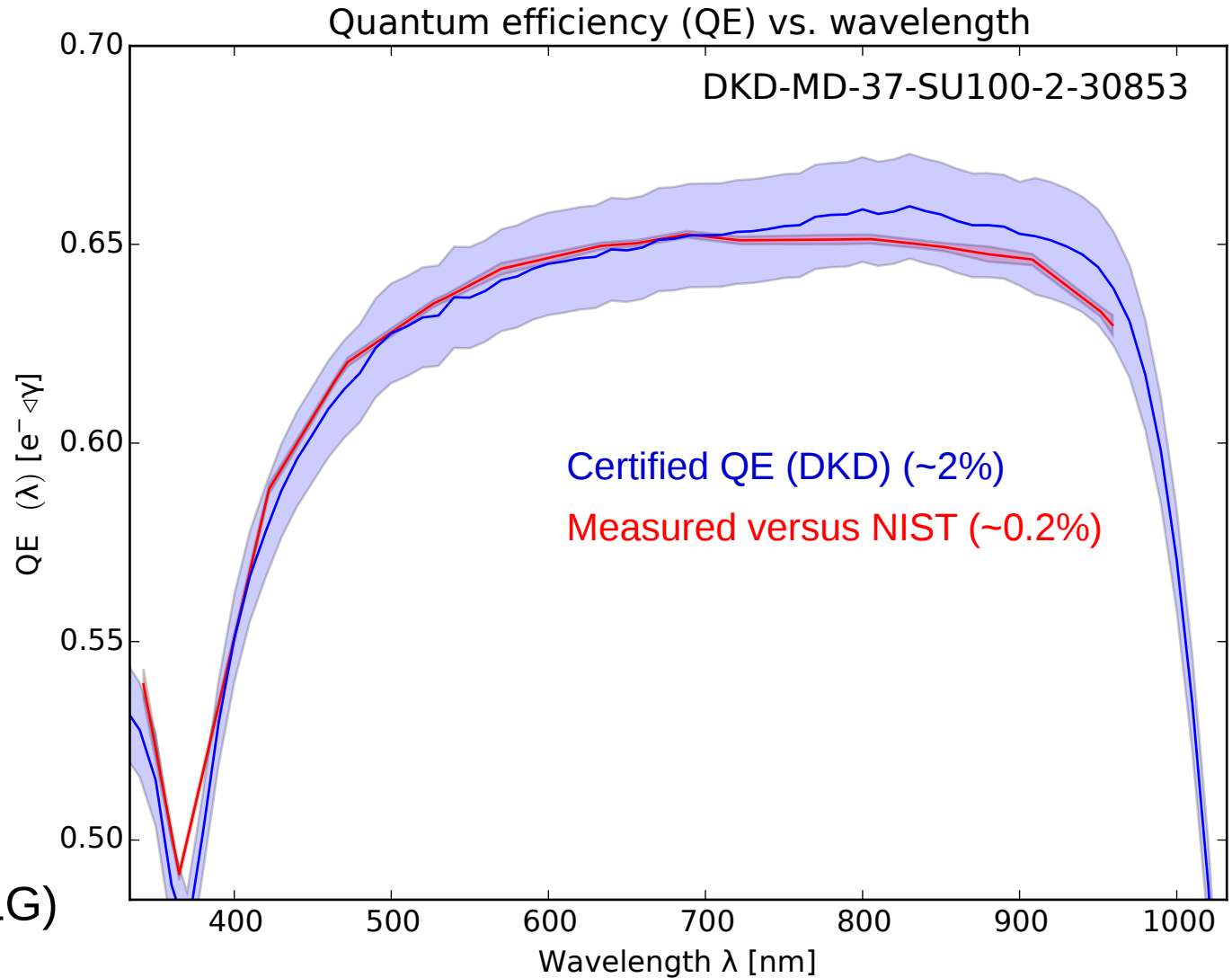
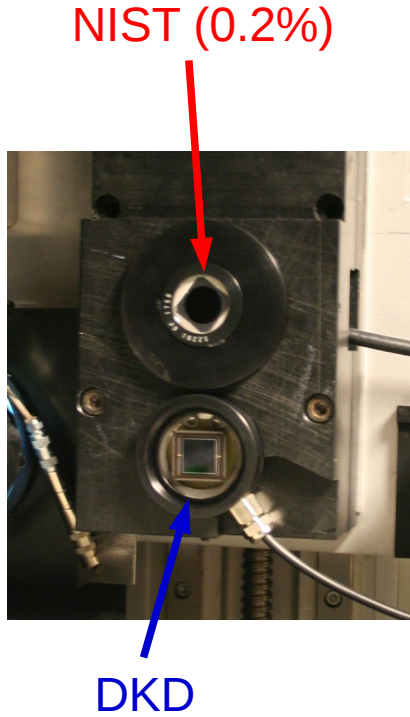

See DESI-2635 (LLG)



Dark Energy Spectroscopic Instrument

Laurent Le Guillou (UPMC/LPNHE), Julien Guy (IN2P3/LPNHE)

DESI Spectrograph telecon – 2017-05-23

19 / 70

# Integration on the AMU Testbench

- **Challenging mechanical interface** between the fiber slit and our device (collision with fiber ends should be avoided at all cost!!)
- **Integration within the AMU testbench software** and the ICS (Xavier Regal, AMU)

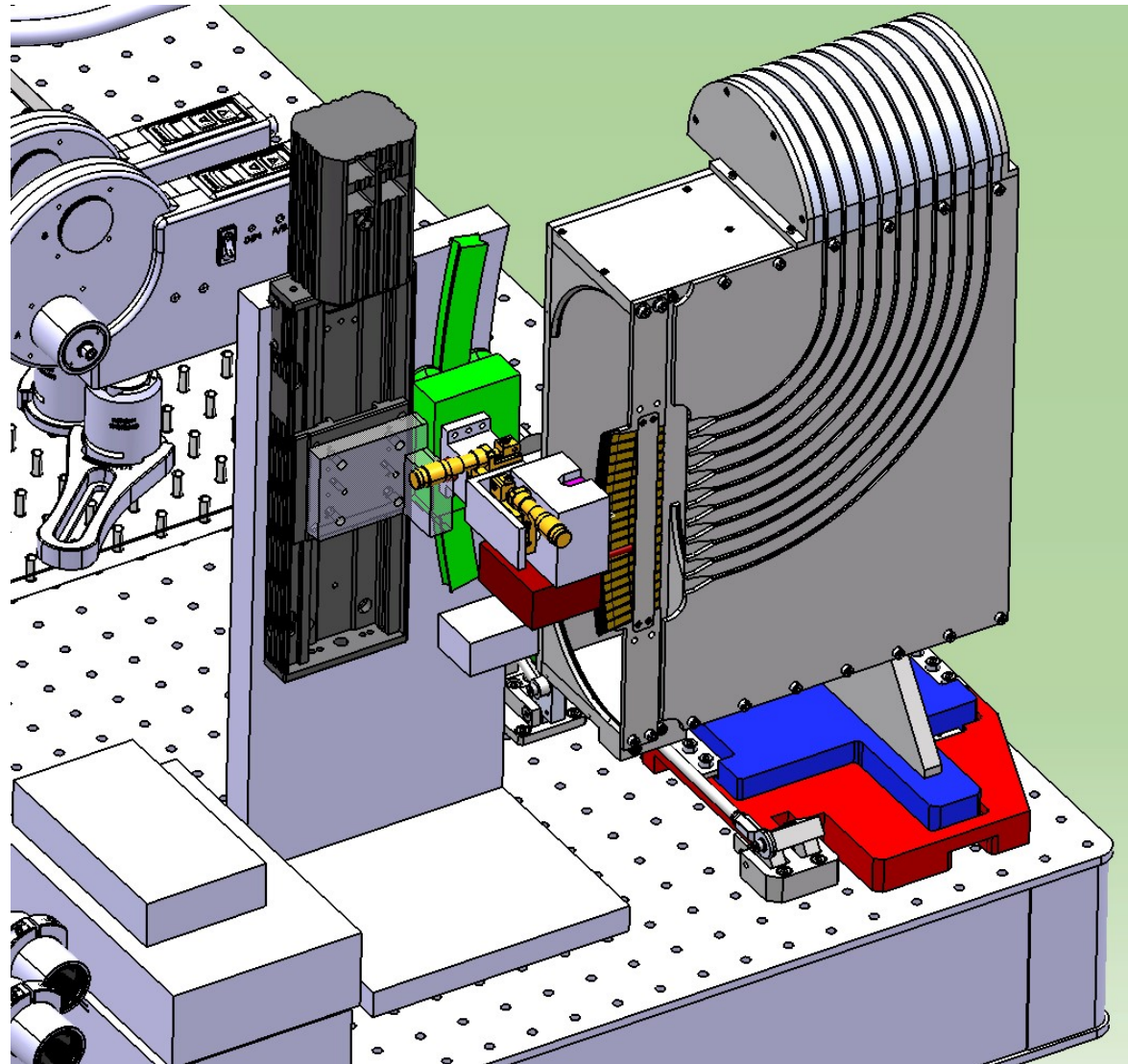

# Integration on the AMU Testbench (dark box)

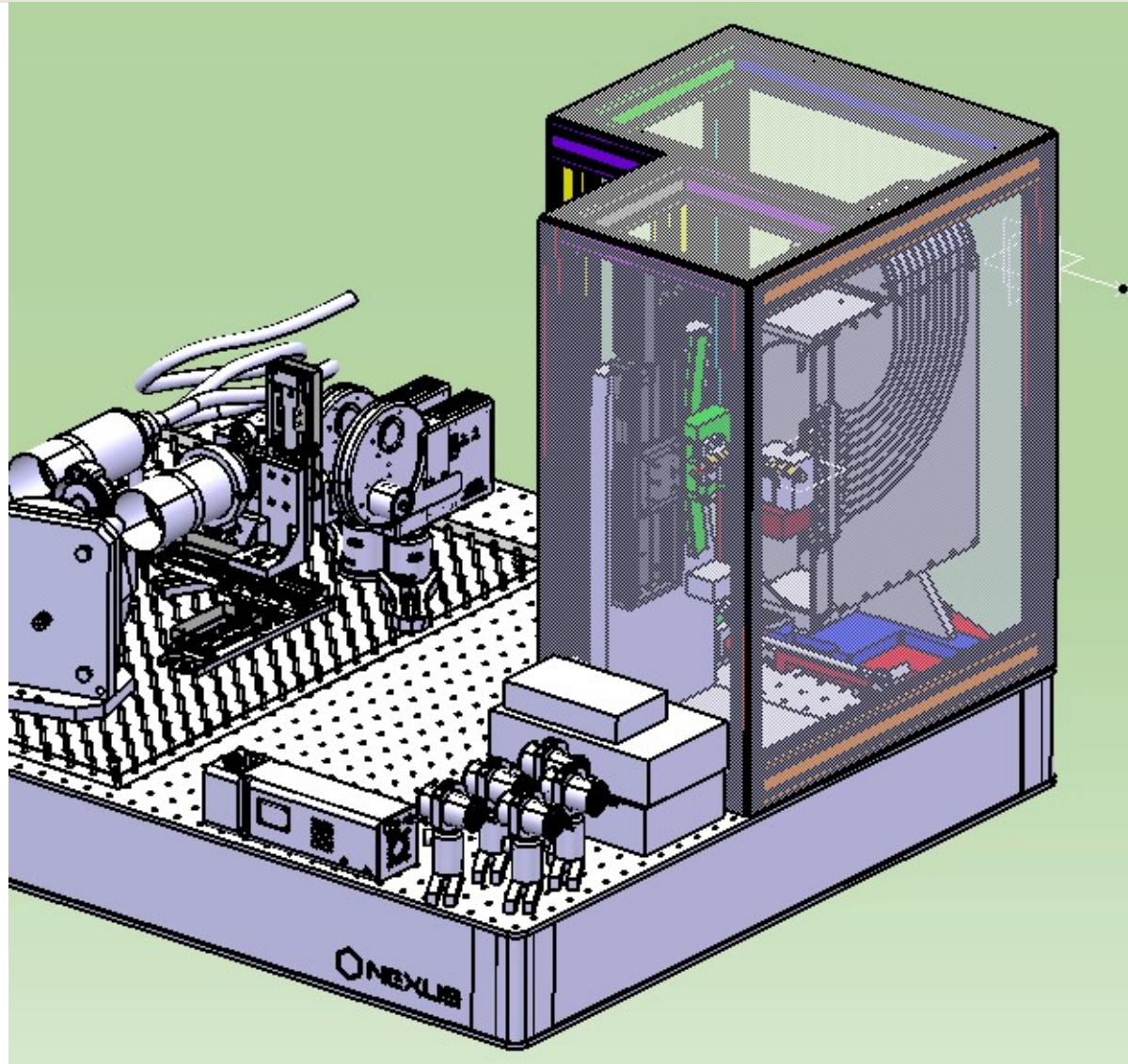

**Dark Energy Spectroscopic Instrument**

Laurent Le Guillou (UPMC/LPNHE), Julien Guy (IN2P3/LPNHE)  
DESI Spectrograph telecon – 2017-05-23

# Installation at Winlight (sept. 2016)

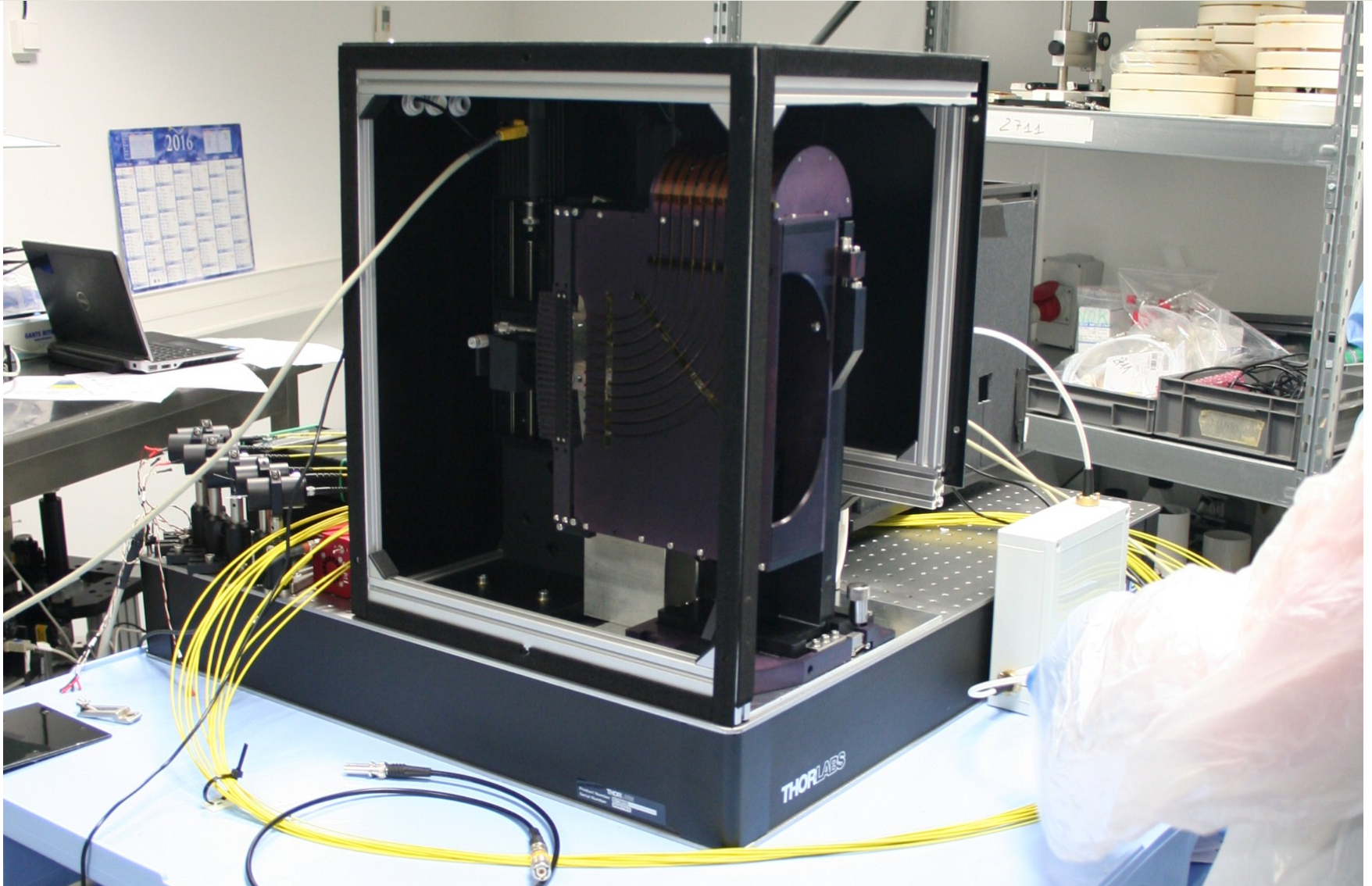

**Dark Energy Spectroscopic Instrument**

Laurent Le Guillou (UPMC/LPNHE), Julien Guy (IN2P3/LPNHE)  
DESI Spectrograph telecon – 2017-05-23

# Installation at Winlight (sept. 2016)

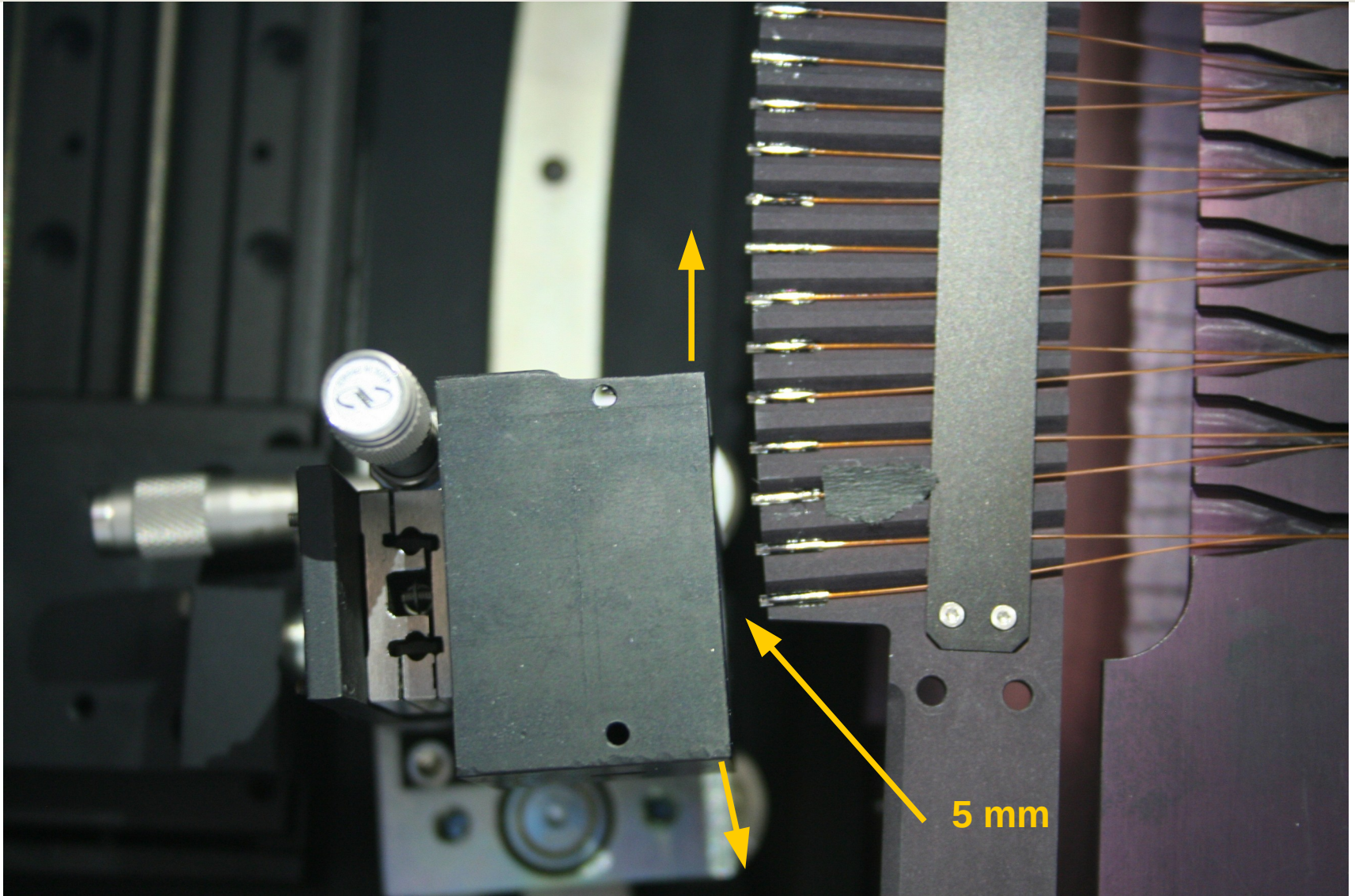

# Installation at Winlight (sept. 2016)

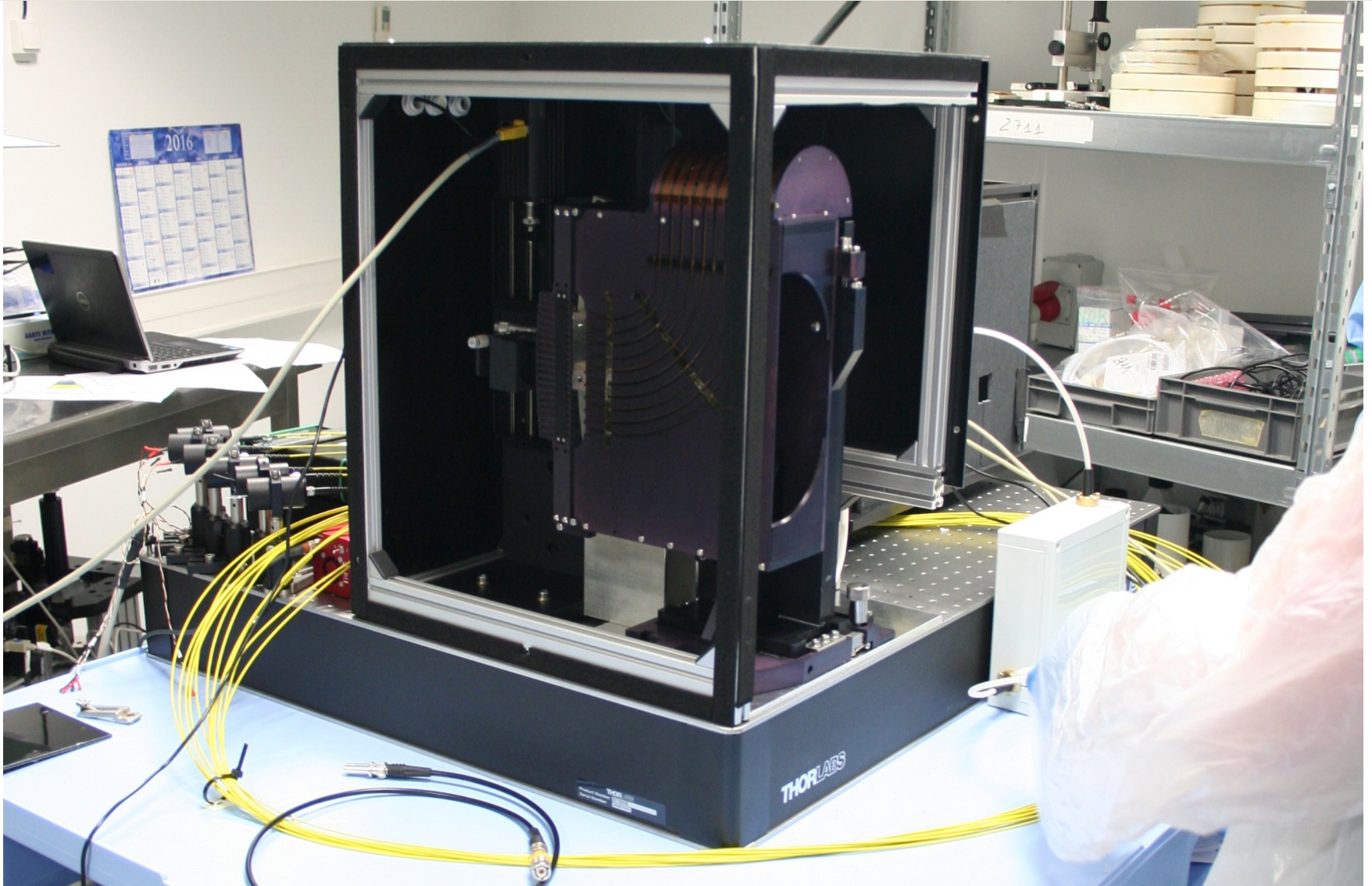

**Dark Energy Spectroscopic Instrument**

Laurent Le Guillou (UPMC/LPNHE), Julien Guy (IN2P3/LPNHE)  
DESI Spectrograph telecon – 2017-05-23



# Scan of the fiber beam by moving the photodiode

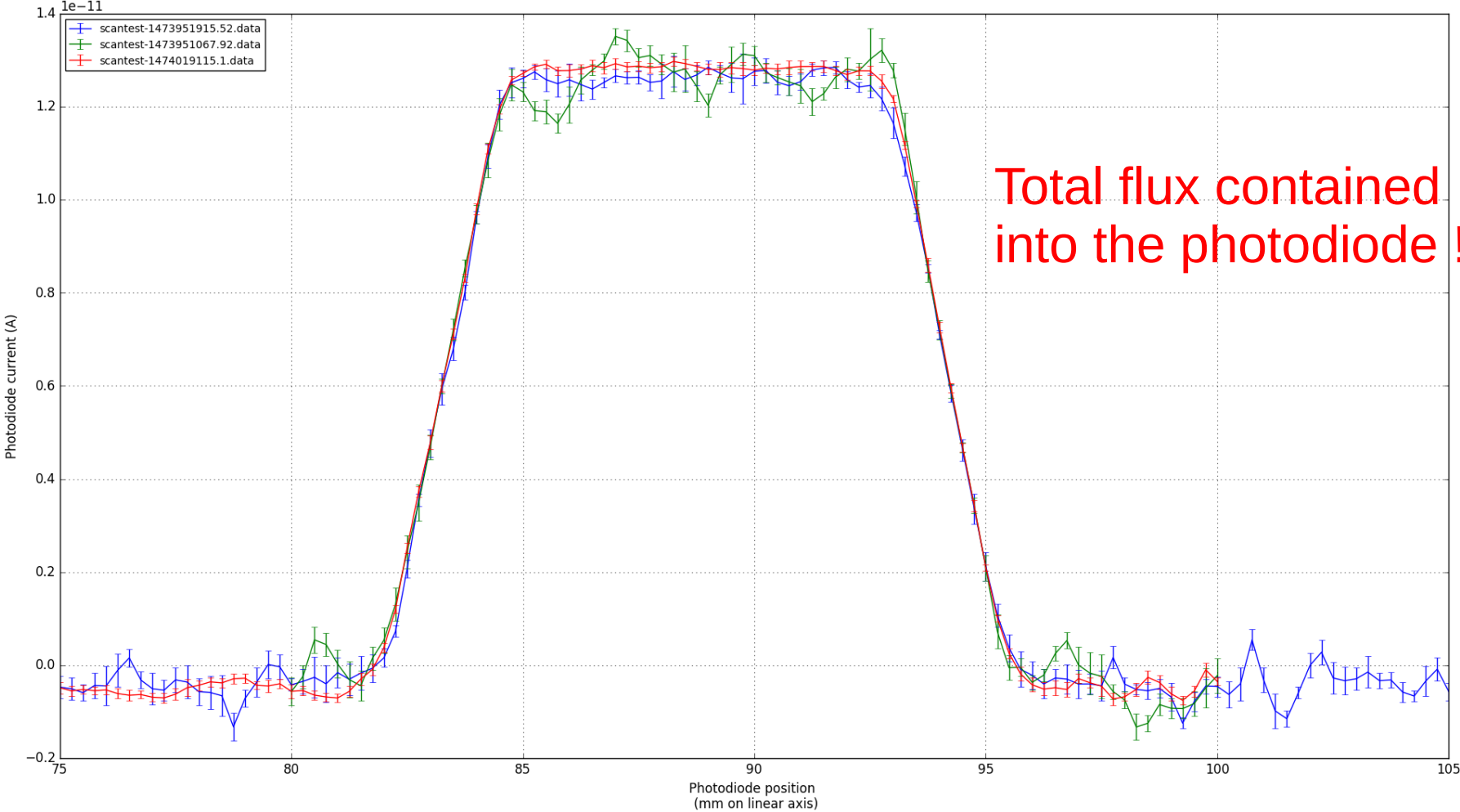

# Measurements campaigns (2017)

- **1<sup>st</sup> campaign: Jan 31 to Feb 2, 2017 (LLG, JG, PEB, SR)**
  - **Absolute flux measurements** (slit in the box)
  - **Separate spectra of all LEDs / individual fibers** (slit in spectro)
  - Scanning the fiber beam with the entire 10x10 photodiode
  - CCD frames to estimate **true shutter time** (W)
  - CCD frames to estimate **the amplifier gains** (W)



# Measurements campaigns (2017)

- **2<sup>nd</sup> campaign: March 14 – 17, 2017 (LLG, PEB, SR)**
  - **Absolute flux measurements** (slit in the box)
  - **Separate spectra of all LEDs / individual fibers** (slit in spectro)
  - Scanning the fiber output beam with the entire photodiode
  - **Scanning the fiber output beam with a 100  $\mu\text{m}$  slit** in front of the photodiode (to model the beam and estimate the FRD)
  - CCD frames to estimate **true shutter time** (W)
  - CCD frames to estimate **the amplifier gains** (W)
  - **Flat slit available: flats, for better ampli. gain measurements**



# Throughput measurement principles

- Measurement to be done during **slit removal/reinstall** repeatability test (limited overhead)
- **Calibration of the total flux** at the exit of each fiber of the sparse fiber slit
- **Proposed Procedure** : for the same illumination setups (LEDs)
  - **(1) Sparse Test Slit outside of the spectrograph, in front of our device** : flux (in the same illumination conditions) measured by our calibrated photodiode for each LED / fiber ;
  - **(2) Sparse Test Slit inside the spectrograph** : integrated flux measured on the CCD for the 3 arms of the spectrograph for each LED / fiber ;
  - **Ratio (1)/(2)** gives **throughput** (from fiber exit to the CCD included)



# Scan of all the sparse slit fibers (centering)

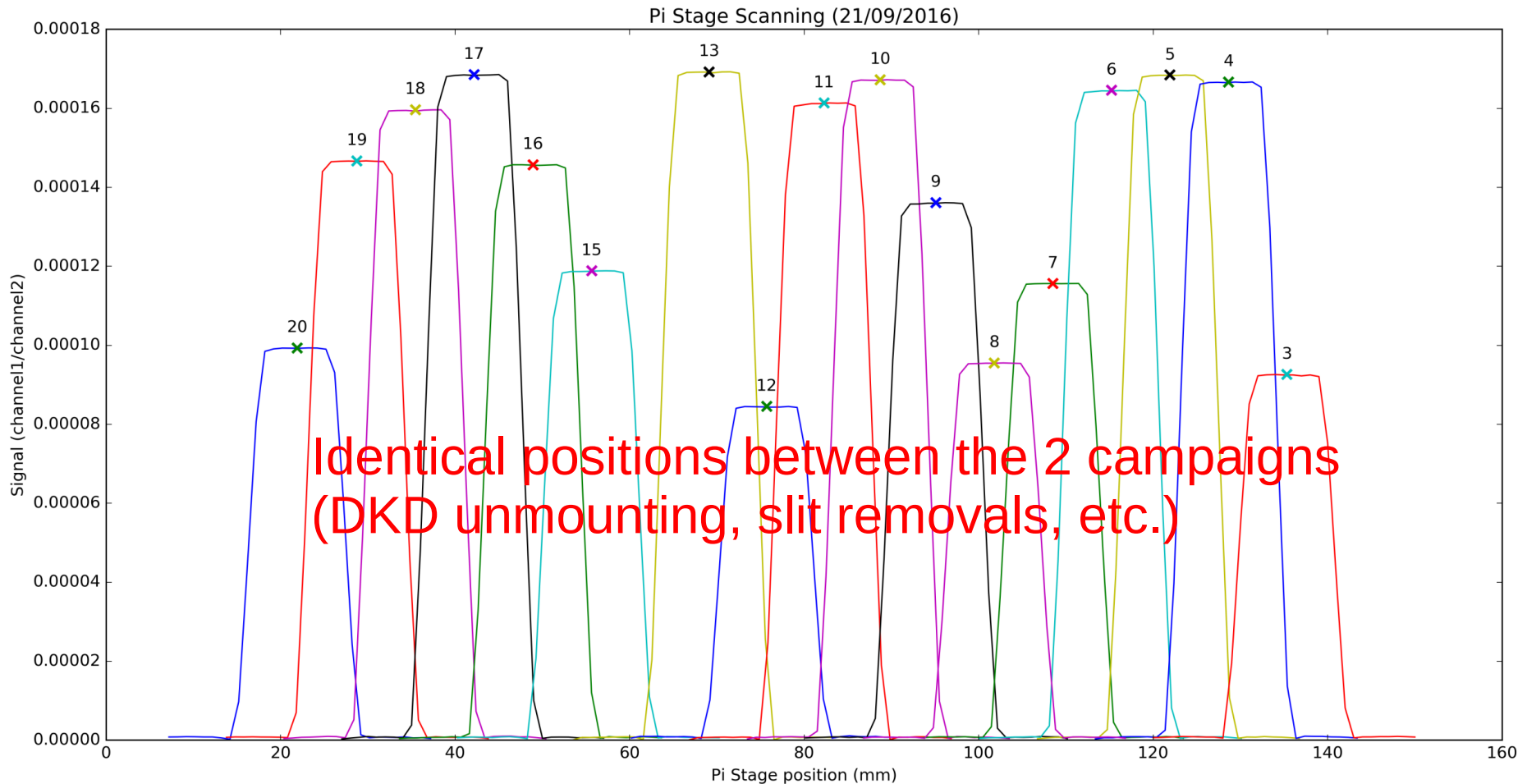

1 broken fiber; last one unreachable (mechanical limit)



# Absolute flux measurements (DKD photocurrent)

- **For each fiber, for each LED :**
  - centering the DK photodiode to catch the whole beam
  - measuring the photocurrent
- **Cycling over OPEN, DARK, and other neutral densities filters**
- **Subtracting dark current**
- **Photocurrents RMS < 0.01 pA**

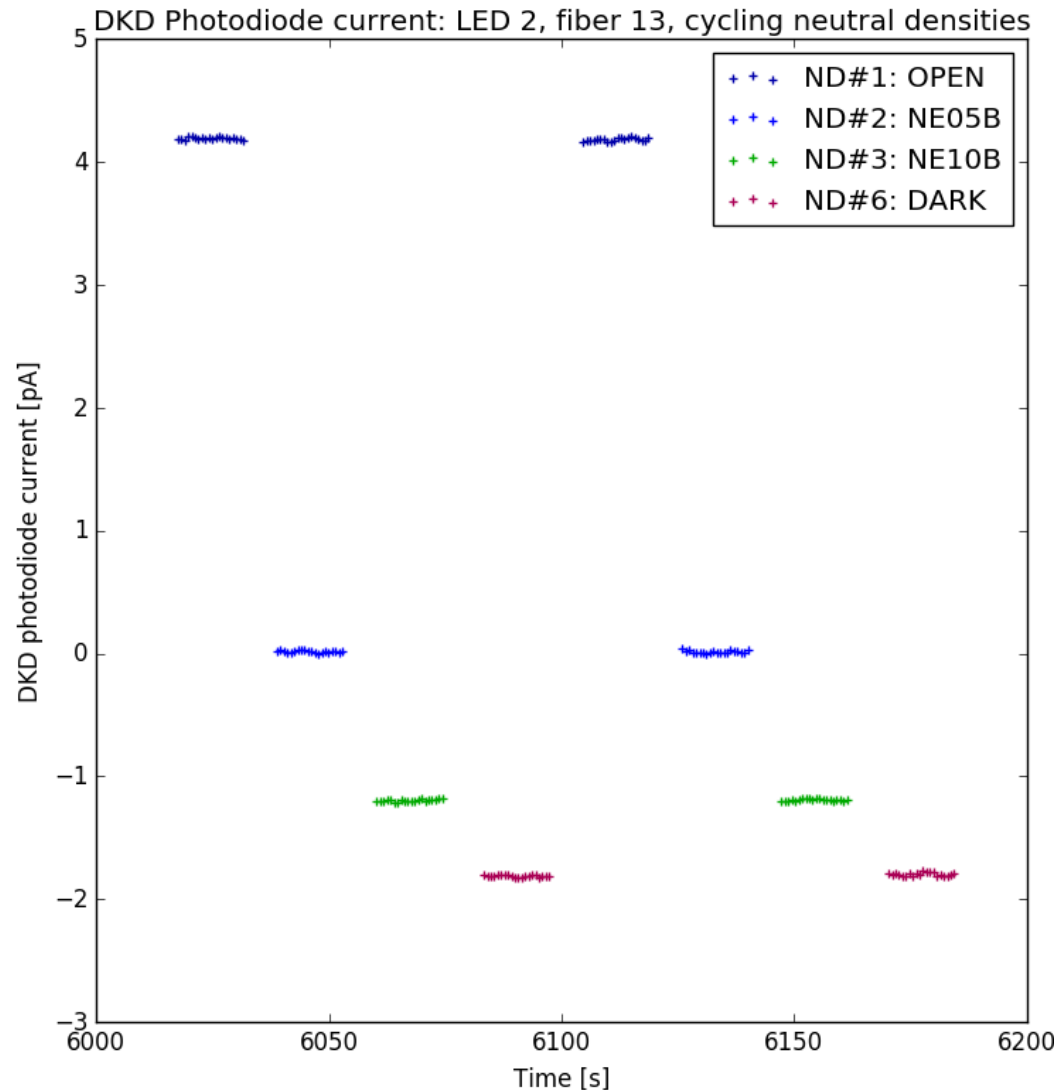
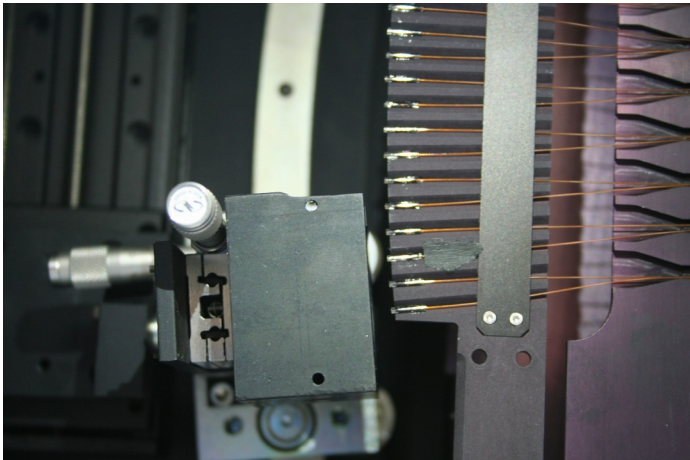

# DKD photocurrents analysis

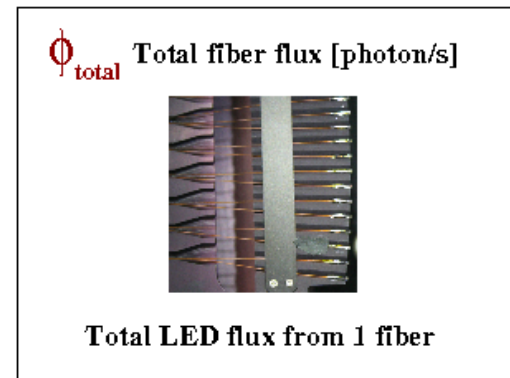
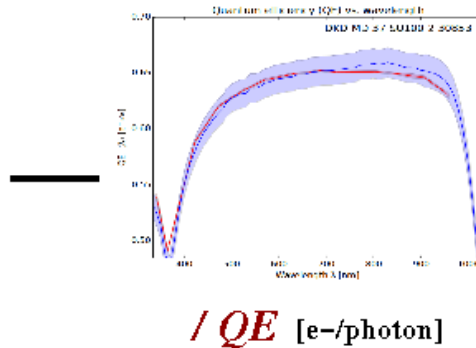
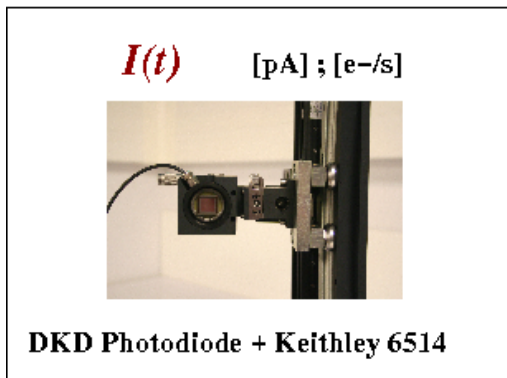

$$\phi_{injected} = \frac{I - I_{dark}}{QE_{DKD, LED}} \times FRD_{fiber}$$

$$QE_{DKD, LED} = \frac{\int \phi_{LED}(\lambda) QE_{DKD}(\lambda) d\lambda}{\int \phi_{LED}(\lambda) d\lambda}$$

FRD correction

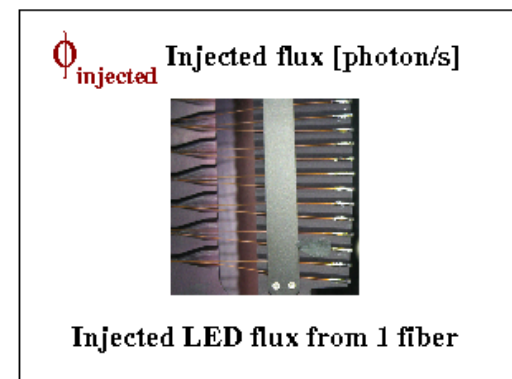

# Throughput measurement principles

- Measurement to be done during **slit removal/reinstall** repeatability test (limited overhead)
- **Calibration of the total flux** at the exit of each fiber of the sparse fiber slit
- **Proposed Procedure** : for the same illumination setups (LEDs)
  - **(1) Sparse Test Slit outside of the spectrograph, in front of our device** : flux (in the same illumination conditions) measured by our calibrated photodiode for each LED / fiber ;
  - **(2) Sparse Test Slit inside the spectrograph** : integrated flux measured on the CCD for the 3 arms of the spectrograph for each LED / fiber ;
  - **Ratio (1)/(2)** gives **throughput** (from fiber exit to the CCD included)





# Integrated LED flux [e-/s] on the 3 CCDs

- For **each LED**, for **each fiber 11 – 20**, a **separate exposure**
- Frames are reduced (DESI pipeline), spectrum region is integrated
- CCD amplifier gains [ADU → e-] are applied
- Resulting CCD flux [e-] is then **divided by the effective exposure time**
- The resulting spectrum is **integrated on the whole arm wavelength range**

$$\phi_{[e-/s]}^{\text{CCD}} = \frac{\text{gain}_{[e-/ADU]}^{\text{ampli}} \times \sum_{\text{ill. pixels}}^{\text{spectrum}} \phi_{[ADU]}^{\text{CCD}} (\text{pixel})}{\Delta t_{[s]}^{\text{exposure}}}$$

- **We need to calibrate the exposure time and the CCDs amplifiers gains**



# LED spectra

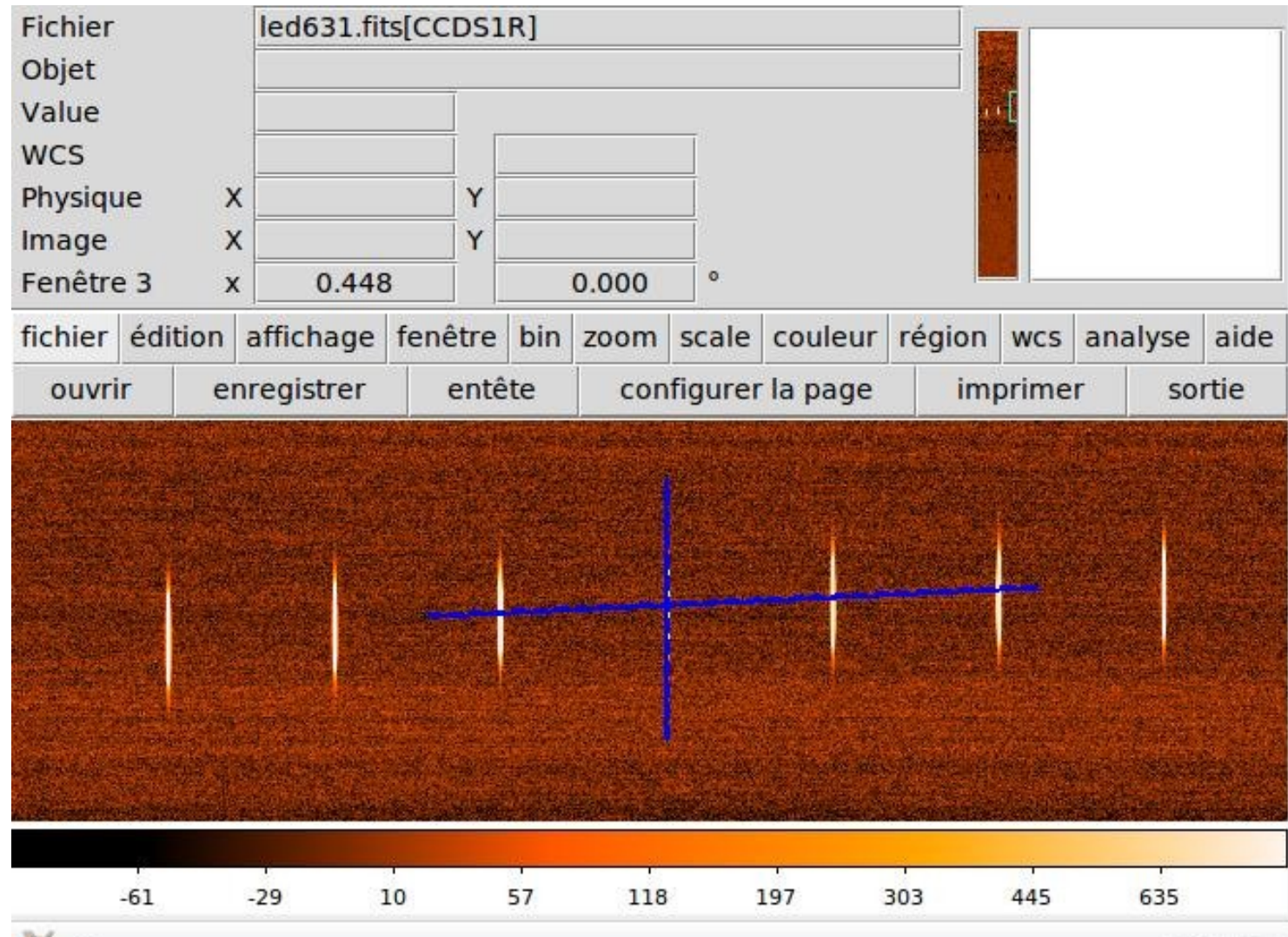

# LED spectrum extraction (pipeline JG)

- **Removing Bias / Dark current** (dark model)
- **Automatic extraction of all fiber spectra**
- **« Boxcar » : sum on 9 CCD pixel wide**
- Wavelength calibration from lamps and PSF model
  - Wavelength calibration better than 0.1 nm  
(no temperature correction)
- We verify that the **background is consistent with zero**
- We assume gain = 1 and the **gain correction is applied later**



# Spectrum in DESI arm B1: LED#1: 370 nm

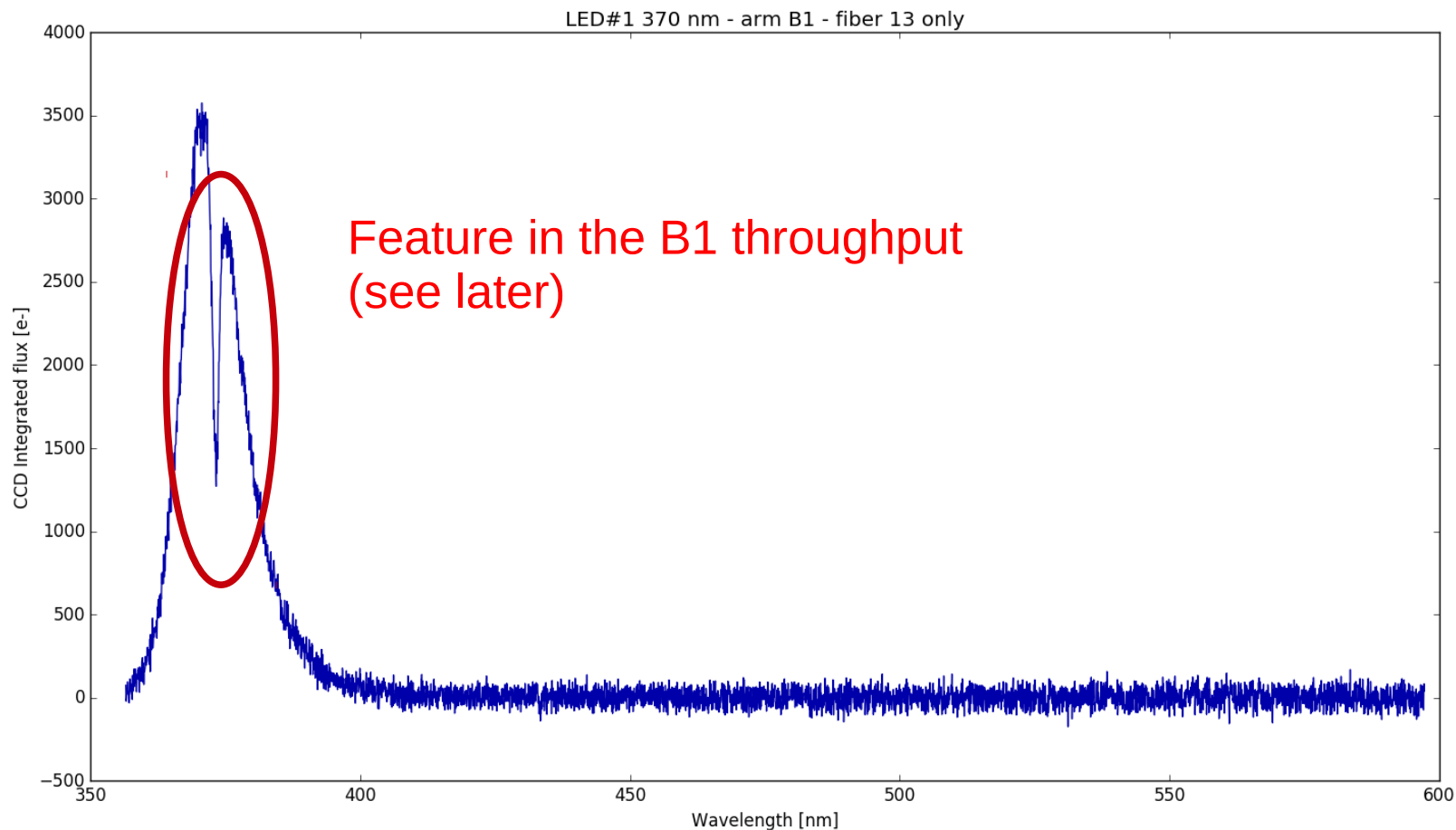

# Spectrum in DESI arm B1: LED#2: 465 nm

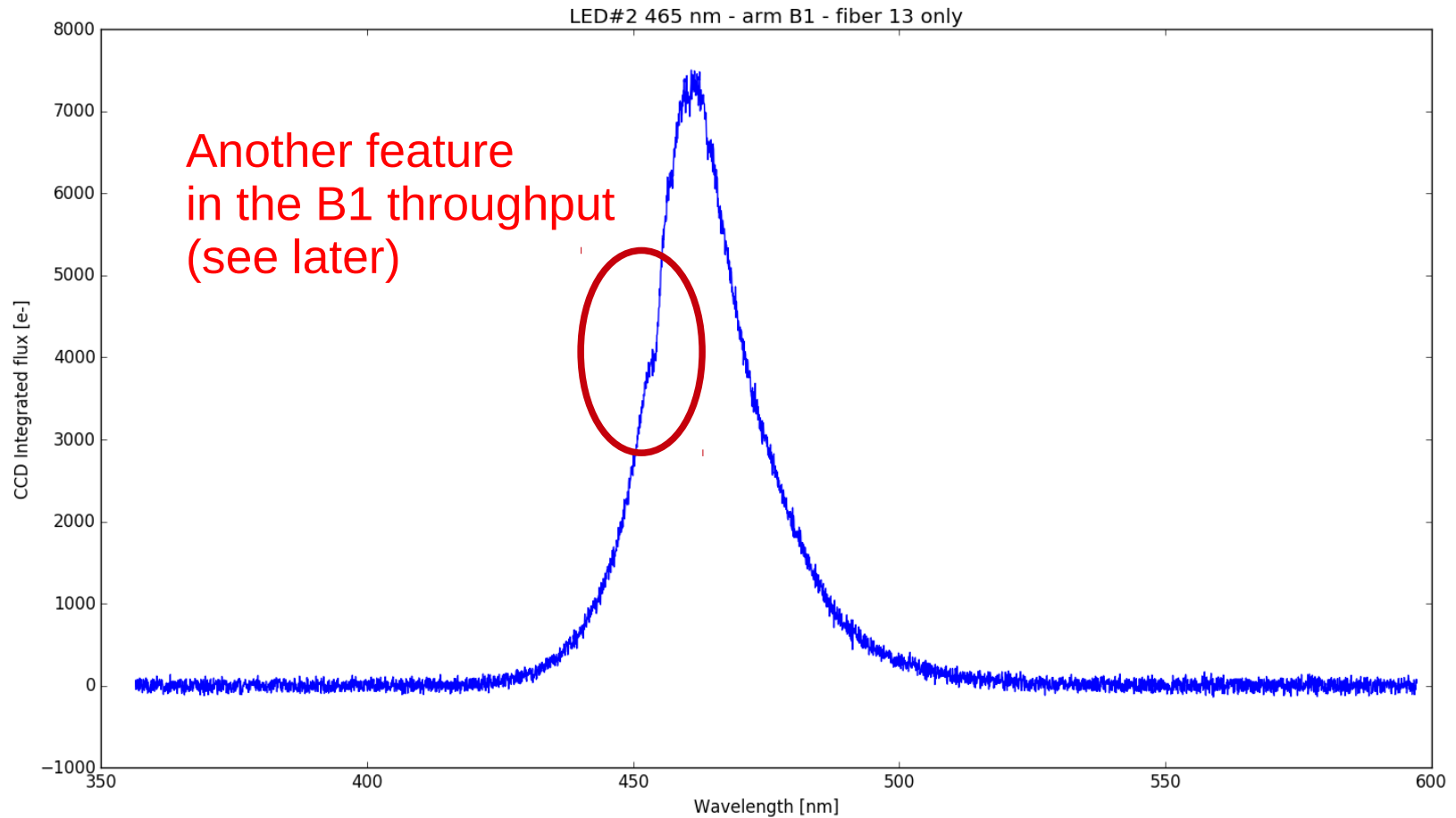

# Spectrum in DESI arm R1: LED#3: 591 nm

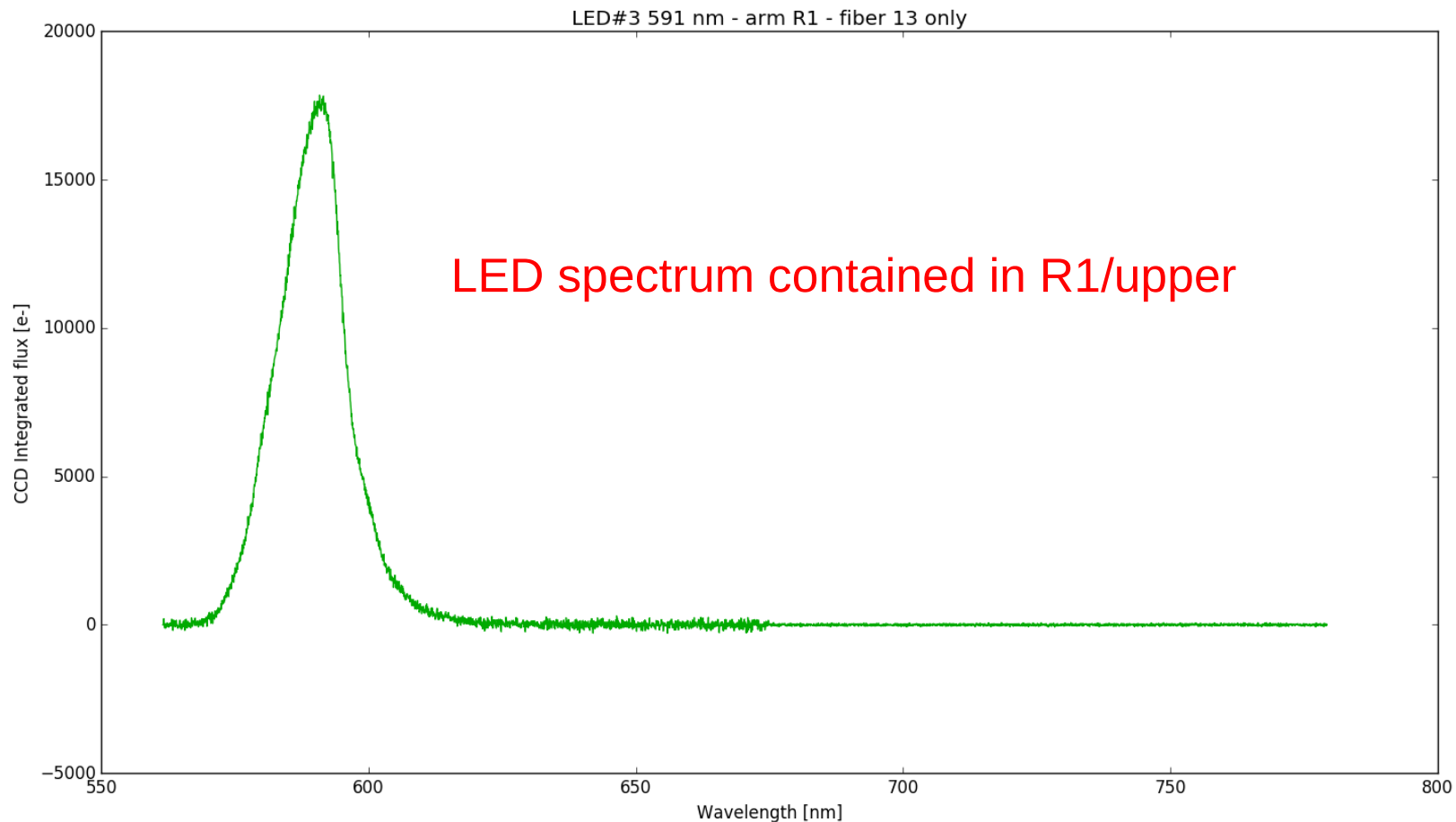

# Spectrum in DESI arm R1: LED#4: 631 nm

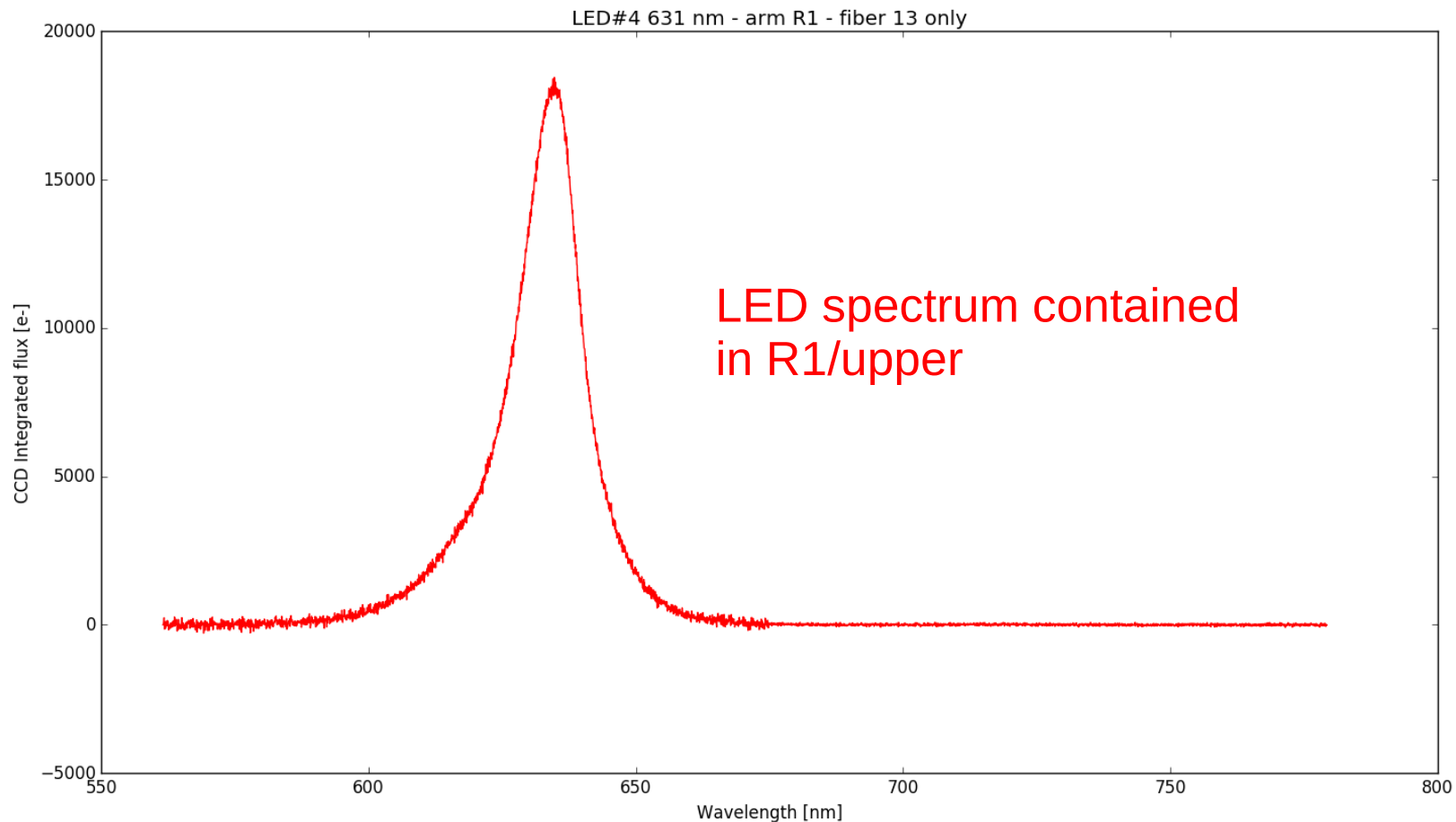

# Spectrum in DESI arm Z1: LED#5: 870 nm

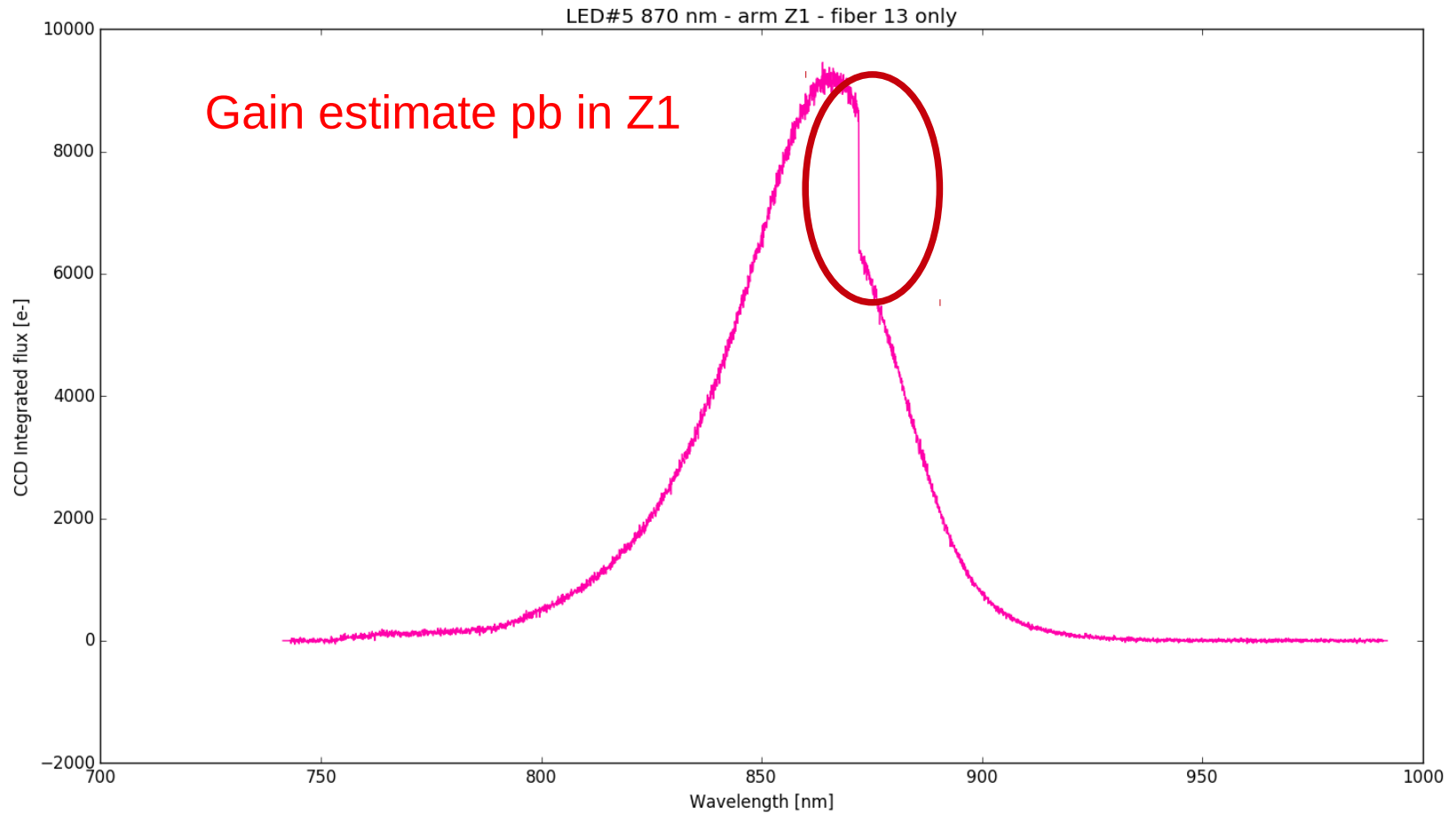



# Spectrum in DESI arm Z1: LED#6: 940 nm

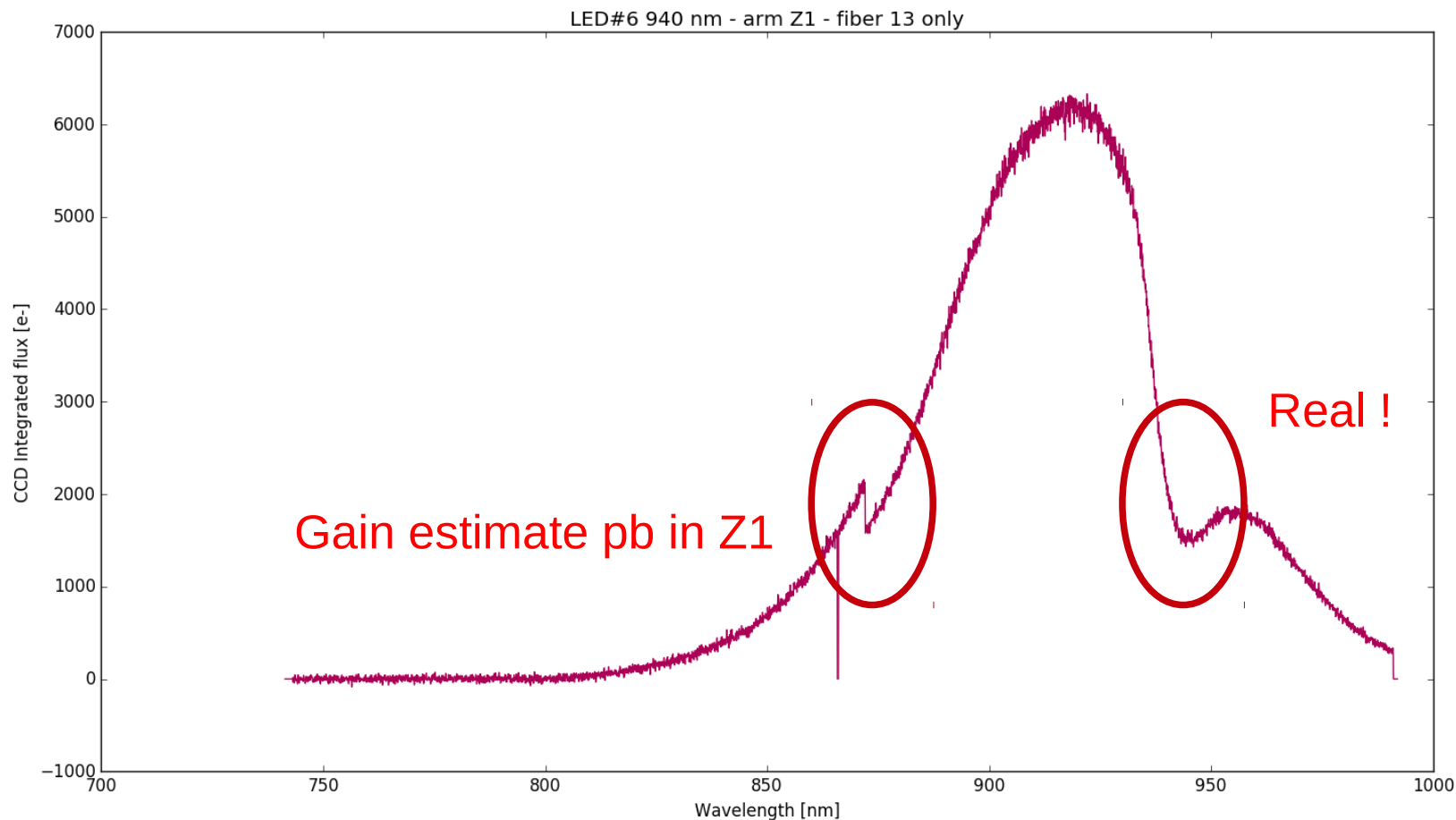

# Exposure time : shutter time correction

- Series of exposures with **increasing exposure time** and **different neutral densities** filters have been taken (first and second campaigns).
- Non-linearity corrections were needed.
- Assuming at least linearity for low fluxes, we were able to estimate an effective exposure time correction (same result on the 3 arms) :

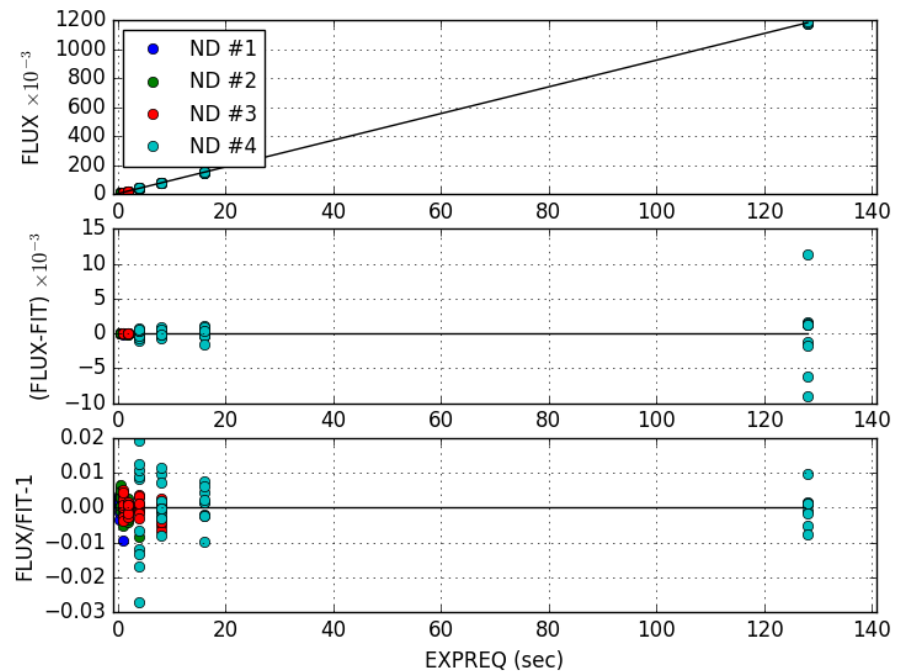

$$\Delta t_{\text{effective}} = [\text{EXPREQ}] + 0.36 \text{ s} \pm 0.01 \text{ s}$$

- **Q : What is EXPTIME (in FITS headers) ?**



# Amplifier gain determination (DESI-2657)

- We measured the amplifier gains **with a PTC (Pixel Transfer Curve)** (variance versus mean flux curve)
- Amplifier gains were estimated in two ways :
  - **Tungsten lamp spectra** (DESI-2657),
    - ramp of exposure time, exposure pairs
  - **Flat with flat slit, tungsten**, (2017-03-29),
    - ramp of exposure time, exposure pairs



# Amplifier gain determination : PTC (arm B)

- **Building PTC** (photon transfer curve) **for each CCD amplifier**
- **b amplifiers** are reasonably **linear**
- **Using tungsten spectra**

Amplifier	gain
B1-A	0.587
B1-B	0.614
B1-C	0.630
B1-D	0.615

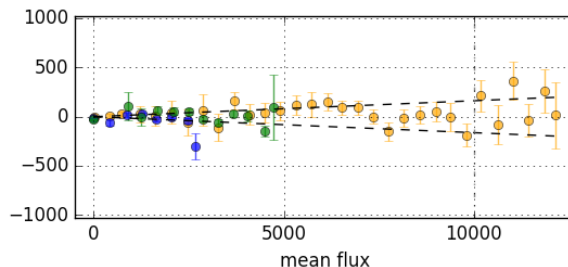
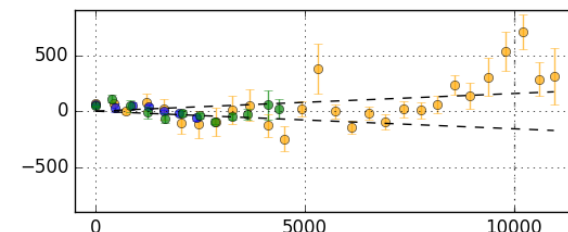
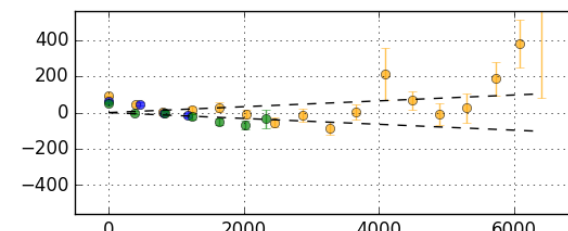
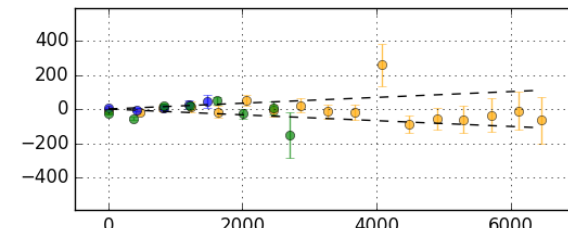
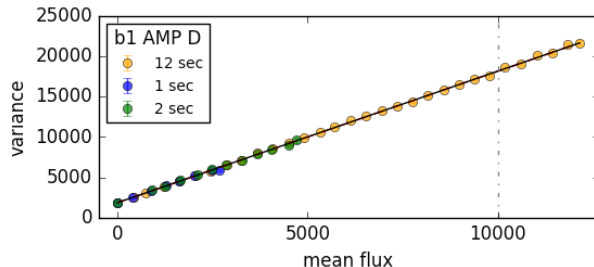
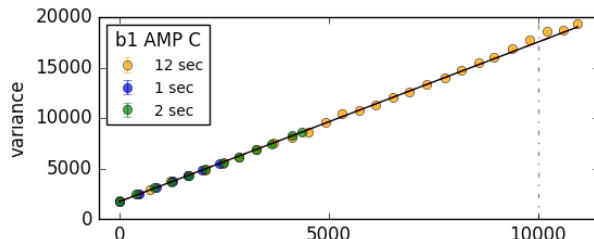
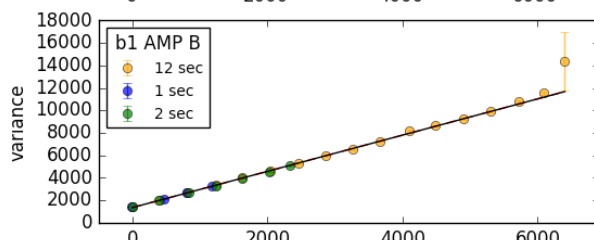
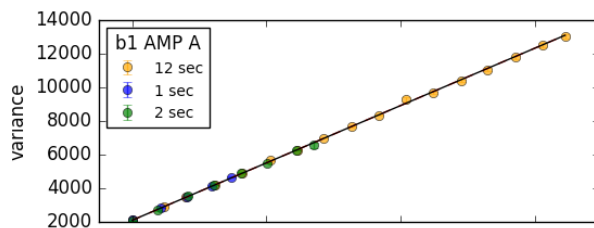

- **See DESI-2657 (JG)**



# Amplifier gain determination : PTC (arm R)

- Amplifier r1-A **unusable**
- **Other r amplifiers** are reasonably **linear**
- **Using tungsten spectra**

Amplifier	gain
R1-A	unusable
R1-B	1.658
R1-C	1.726
R1-D	1.723

- **See DESI-2657 (JG)**

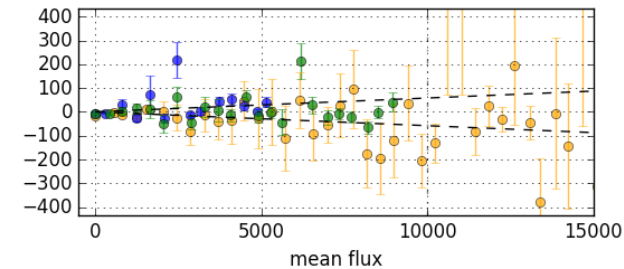
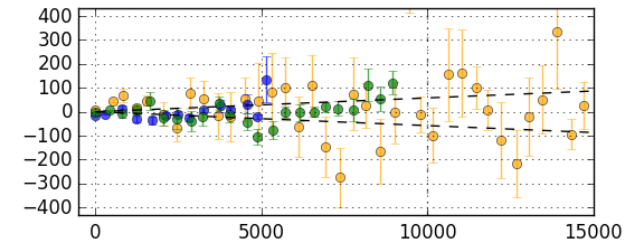
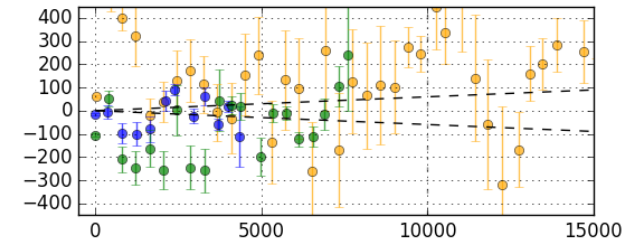
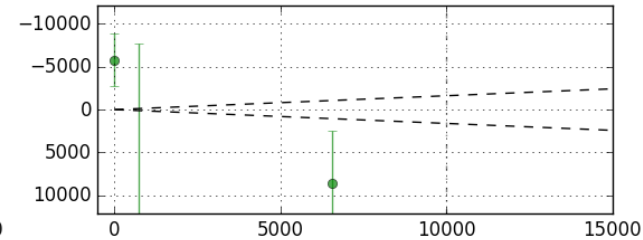
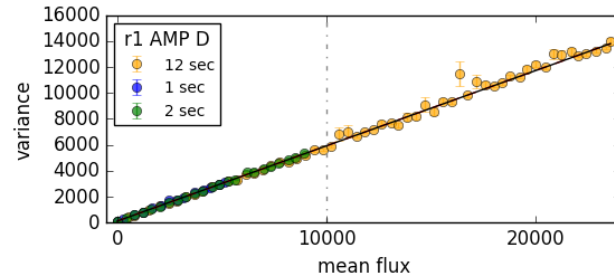
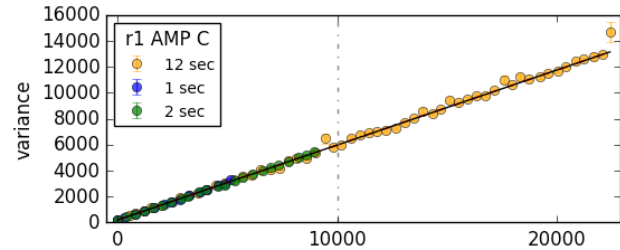
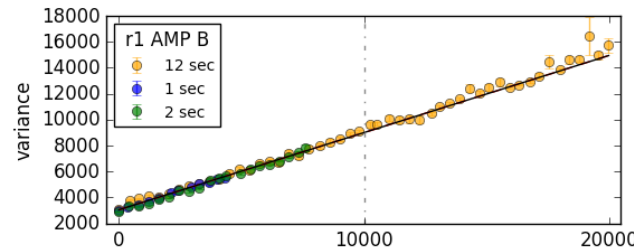
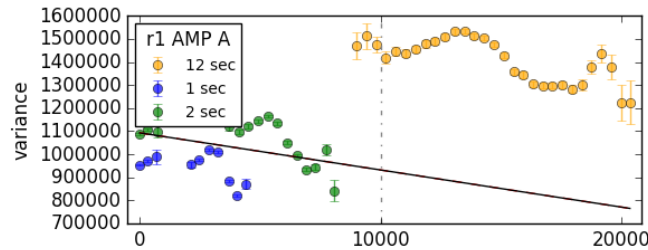

# Amplifier gain determination : PTC (arm Z)

- Highly non-linear amplifiers
- Z1-C unusable
- Using tungsten spectra

Amplifier	Gain (< 5000)
Z1-A	1.072
Z1-B	1.135
Z1-C	Unusable
Z1-D	0.774

- See DESI-2657 (JG)

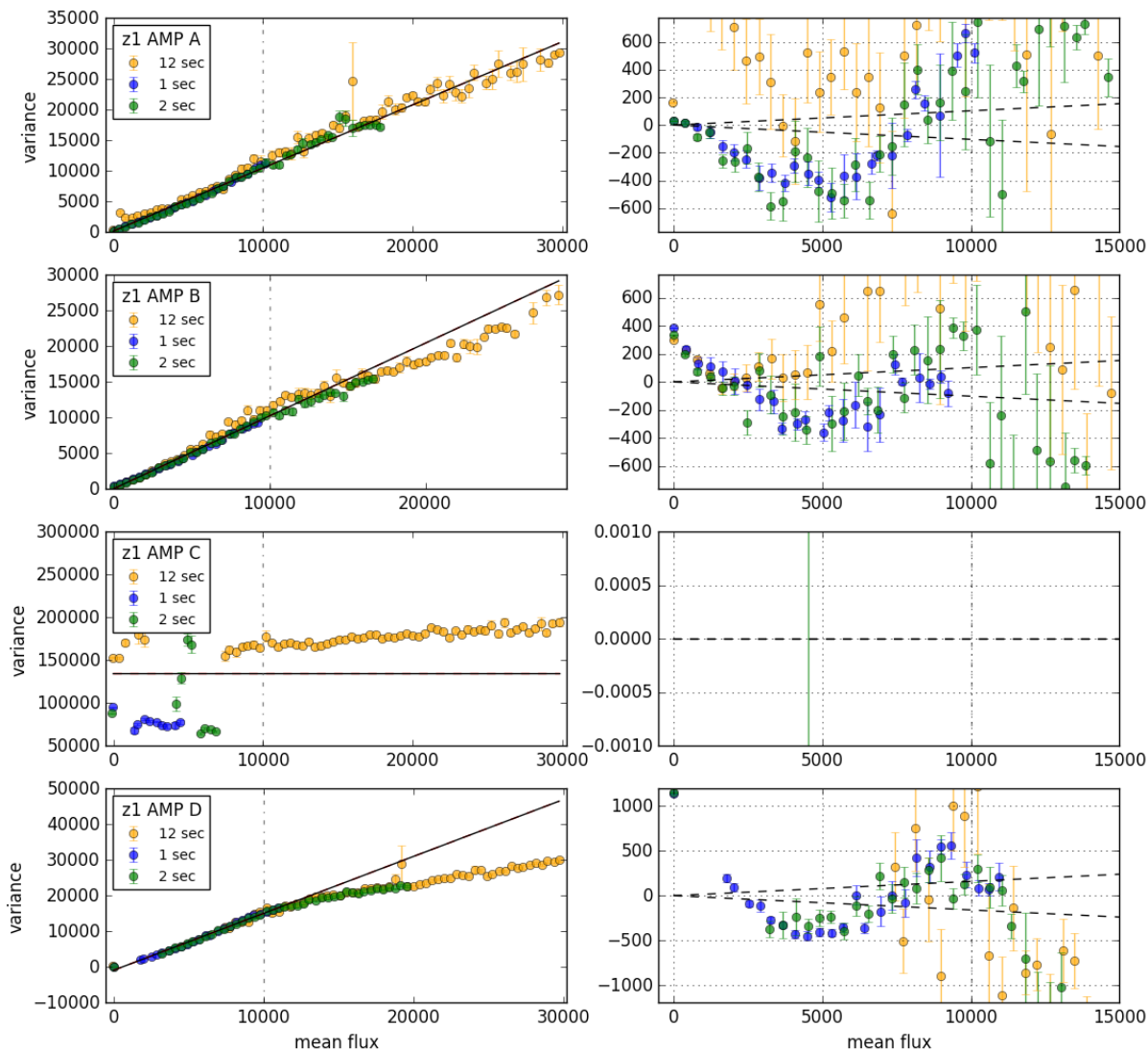

# Amplifier gain (flat slit, tungsten): b1-D

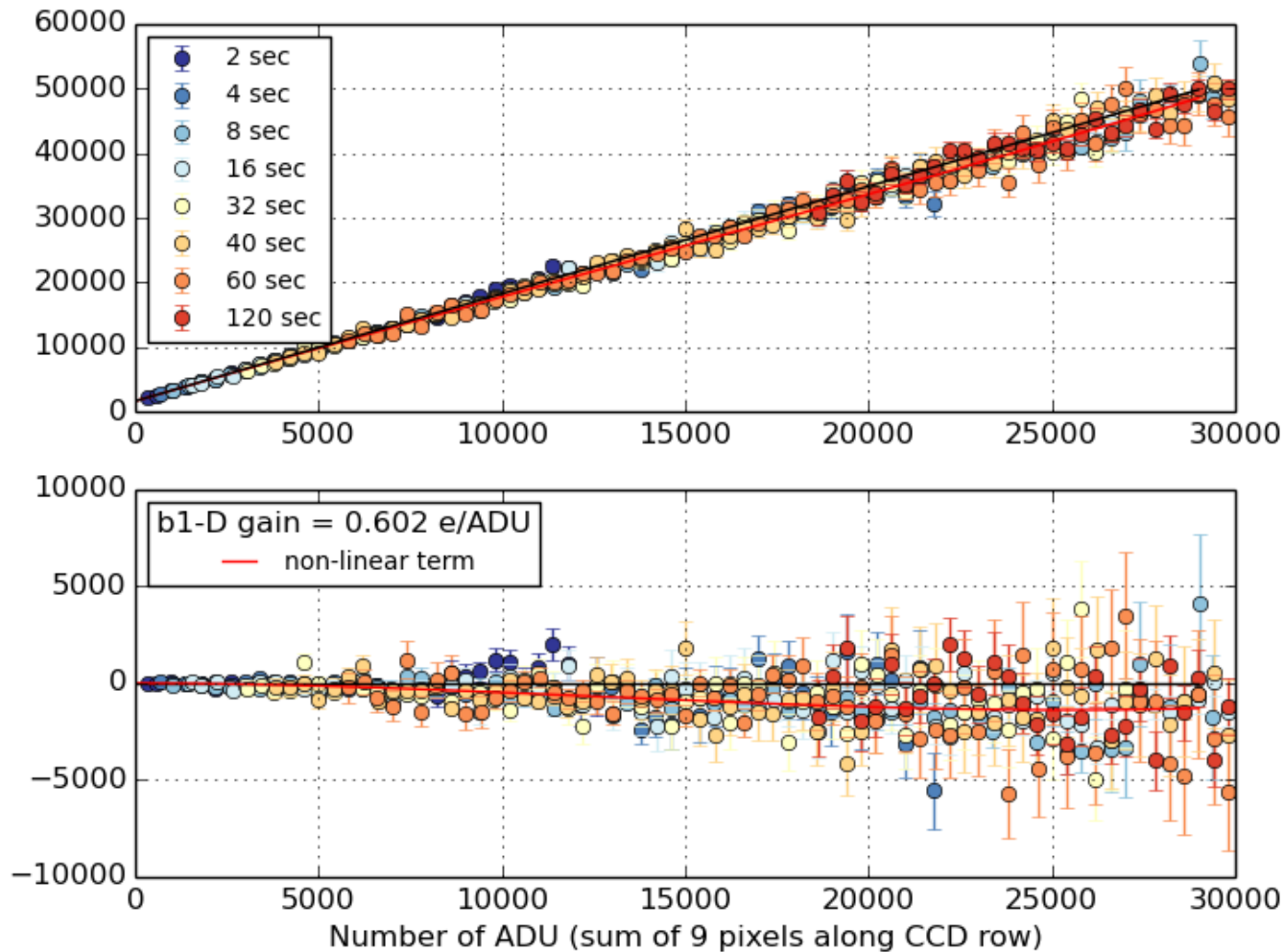

# Amplifier gain (flat slit, tungsten): r1-B

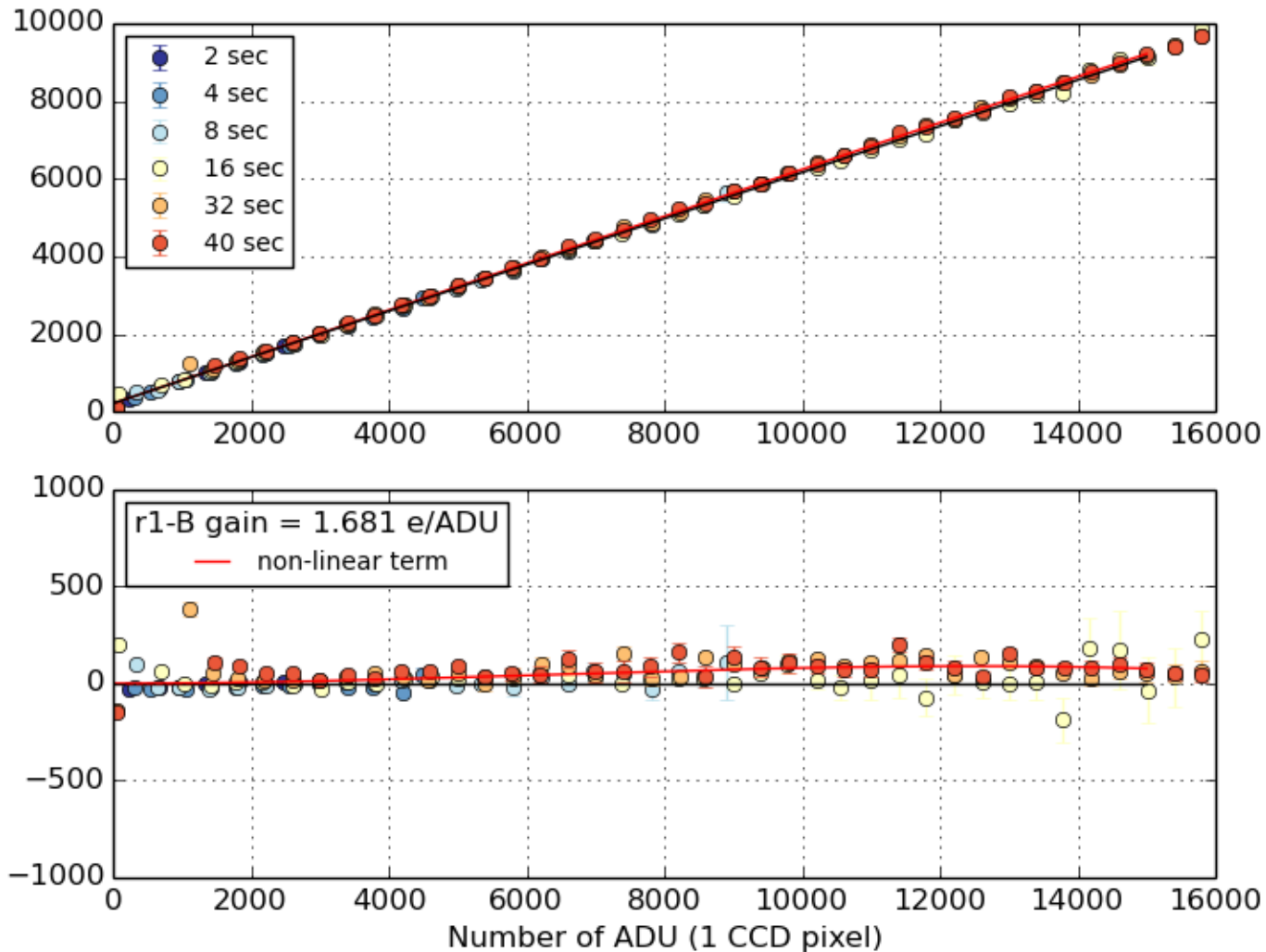



# Amplifier gain (flat slit, tungsten): z1-B

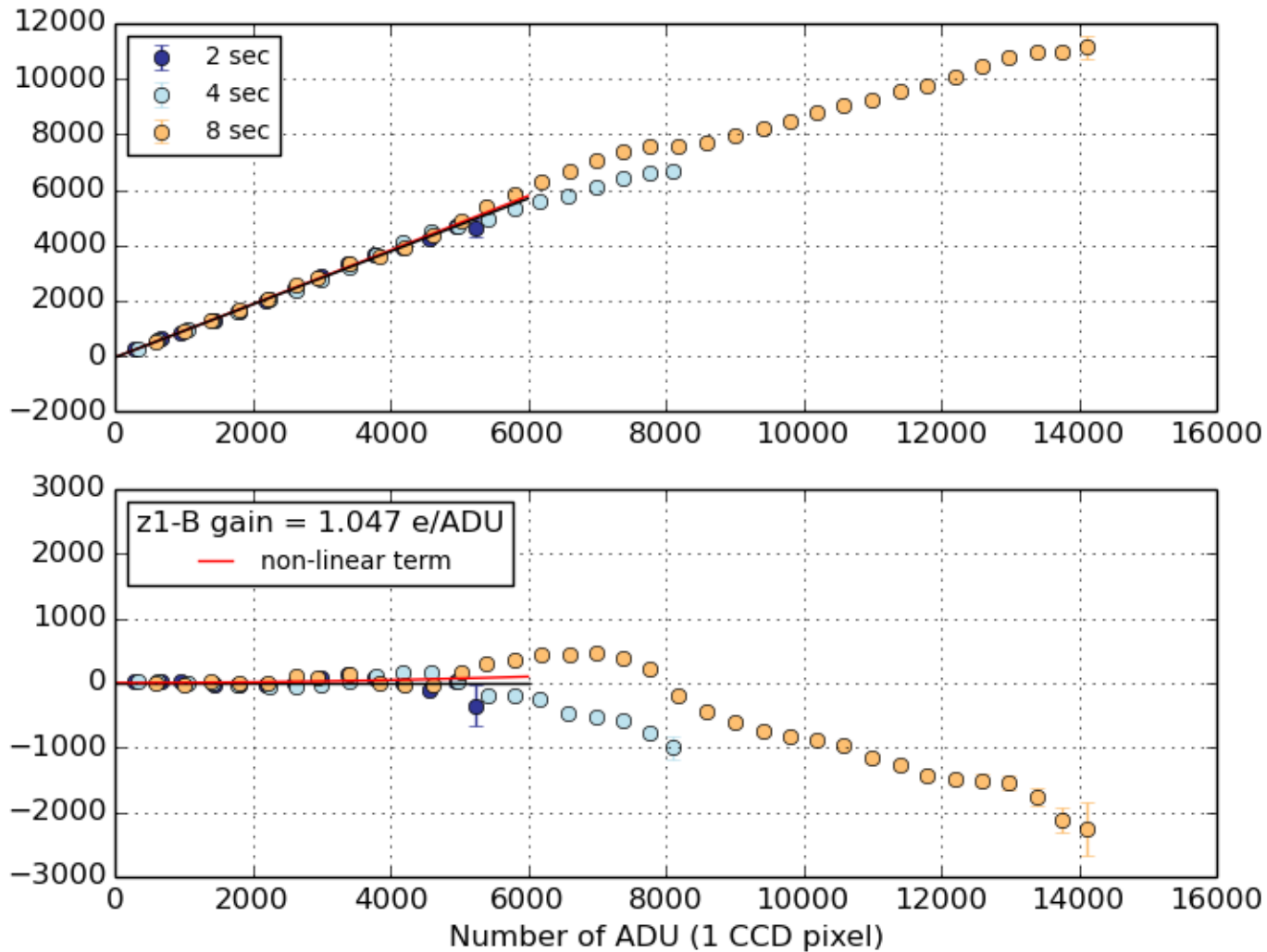

# Amplifier gain determination (flat slit, tungsten)

- Gains obtained with a PTC with **flat slit exposure, tungsten lamp** :

Amplifier	gain
B1-A	0.546
B1-B	0.619
B1-C	0.624
B1-D	0.602

Amplifier	gain
R1-A	unusable
R1-B	1.681
R1-C	1.666
R1-D	1.677

Amplifier	Gain (< 5000)
Z1-A	–
Z1-B	1.047
Z1-C	???
Z1-D	0.687

- For this analysis, we used the gains **obtained from the flat slit exposures** (seem more reliable)
- For **b1 & r1**, gain systematics around 3 %
- For **z1**, huge uncertainties due to the important non-linearity



# Measurement strategy: using fibers 11 – 20

- r1-A unusable
- z1-C unusable
- We choose to take LED spectra only with amplifiers B and D  
→ fibers 11 to 20
- Limiting the flux in all spectra (< 5000 ADU in all pixels) to avoid amplifiers non-linearity

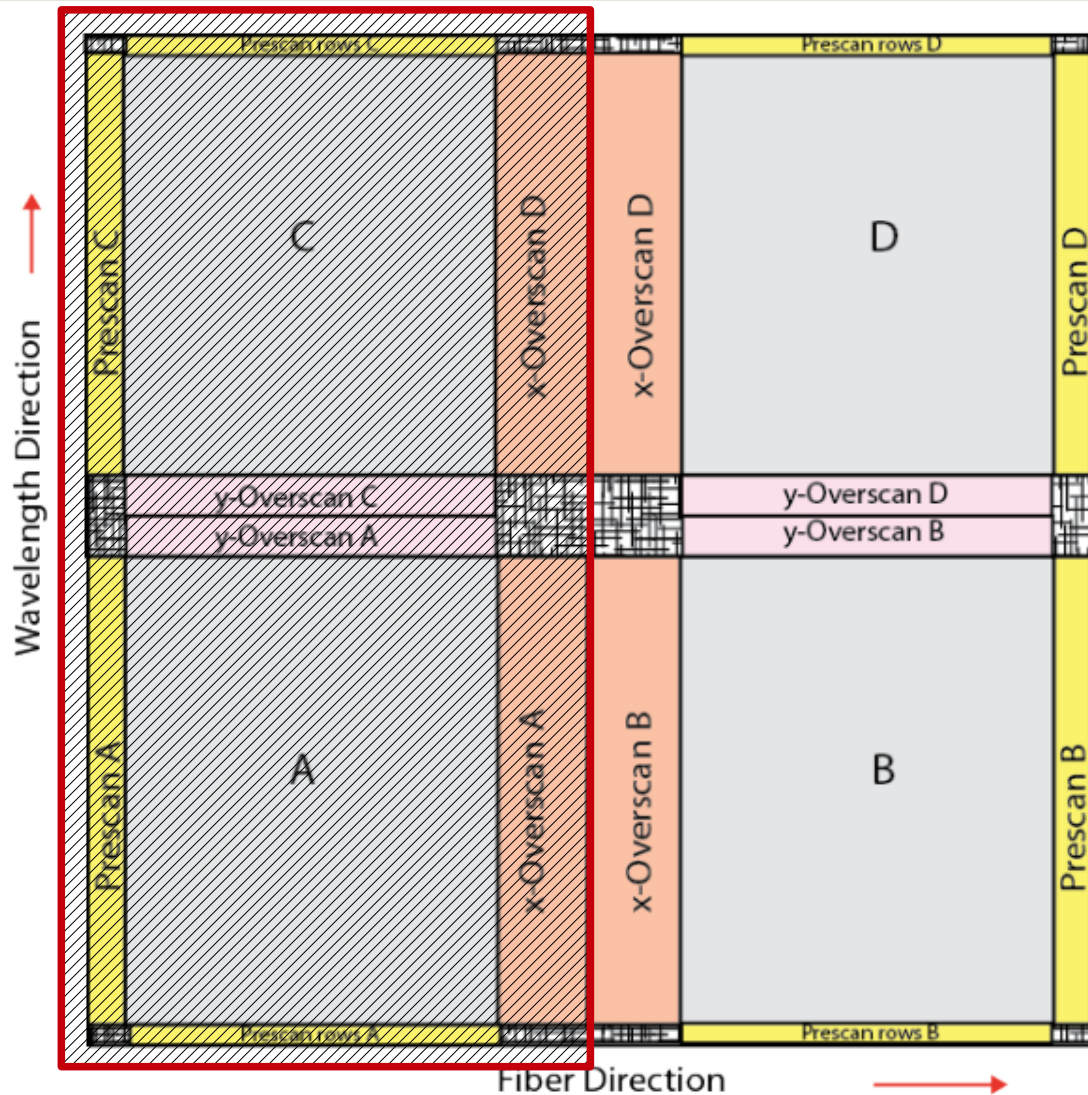

# Direct throughput estimate (without a model)

- We first estimate the spectrograph throughput by **dividing the integrated flux in each CCD** (for each LED and each fiber 11-20) by the **injected flux (DKD)** :

$$\eta_{[e^-/\gamma]}(\lambda_{\text{LED}}) = (QE_{\text{CCD}} \times T_{\text{optics}}(\lambda_{\text{LED}})) = \frac{\phi_{[e^-/s]}^{\text{CCD}}(\text{LED})}{\phi_{[\gamma/s]}^{\text{injected}}(\text{LED})}$$

- For the moment, no FRD correction (see below).
- What we got that way is an **estimate of the spectrograph throughput** at the LED wavelength (weighted by the LED spectrum)
- Comparison with the **DESI optical model (without fibers)**



# Direct throughput estimate (without a model)

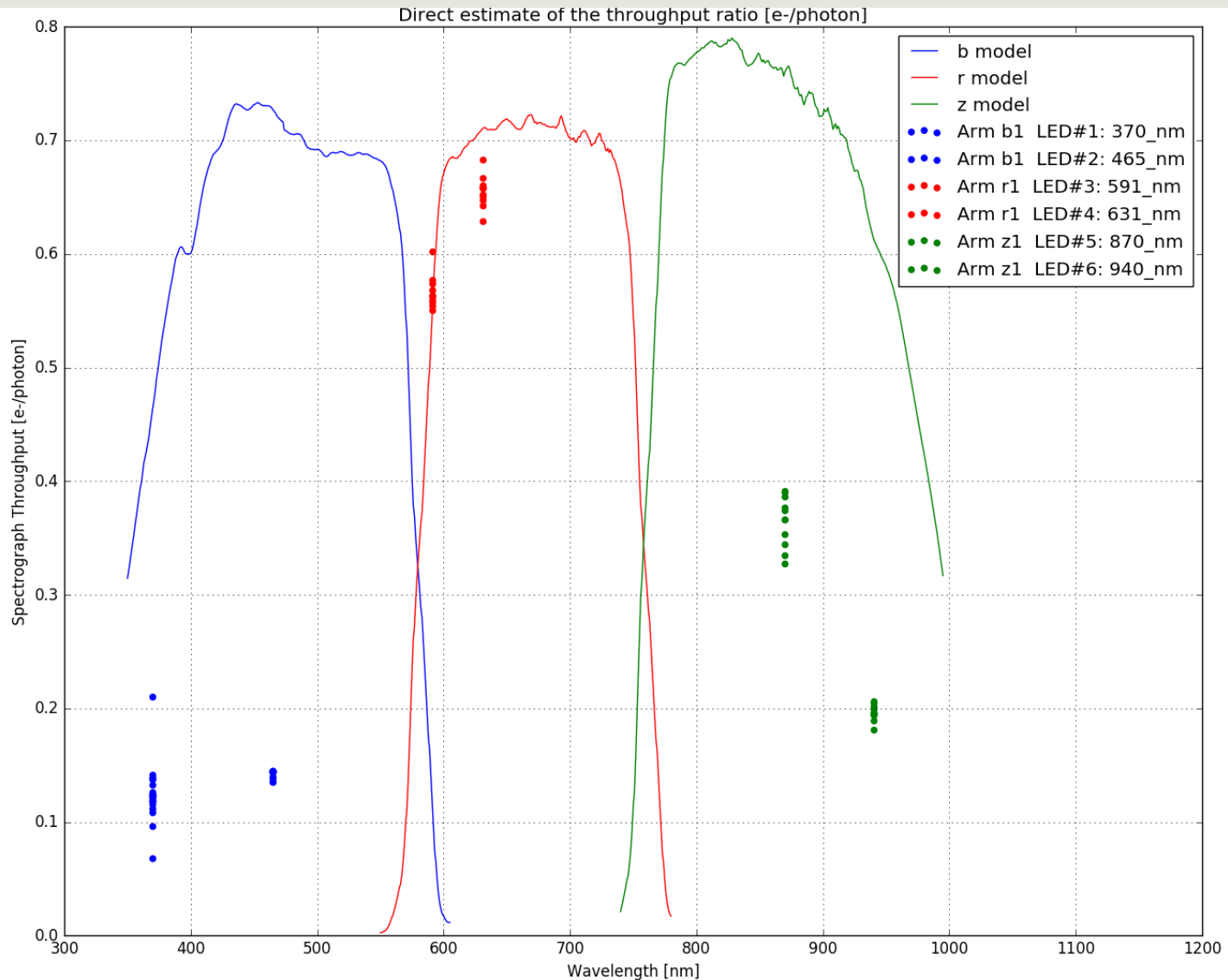

Direct estimate of the throughput ratio [e-/photon]

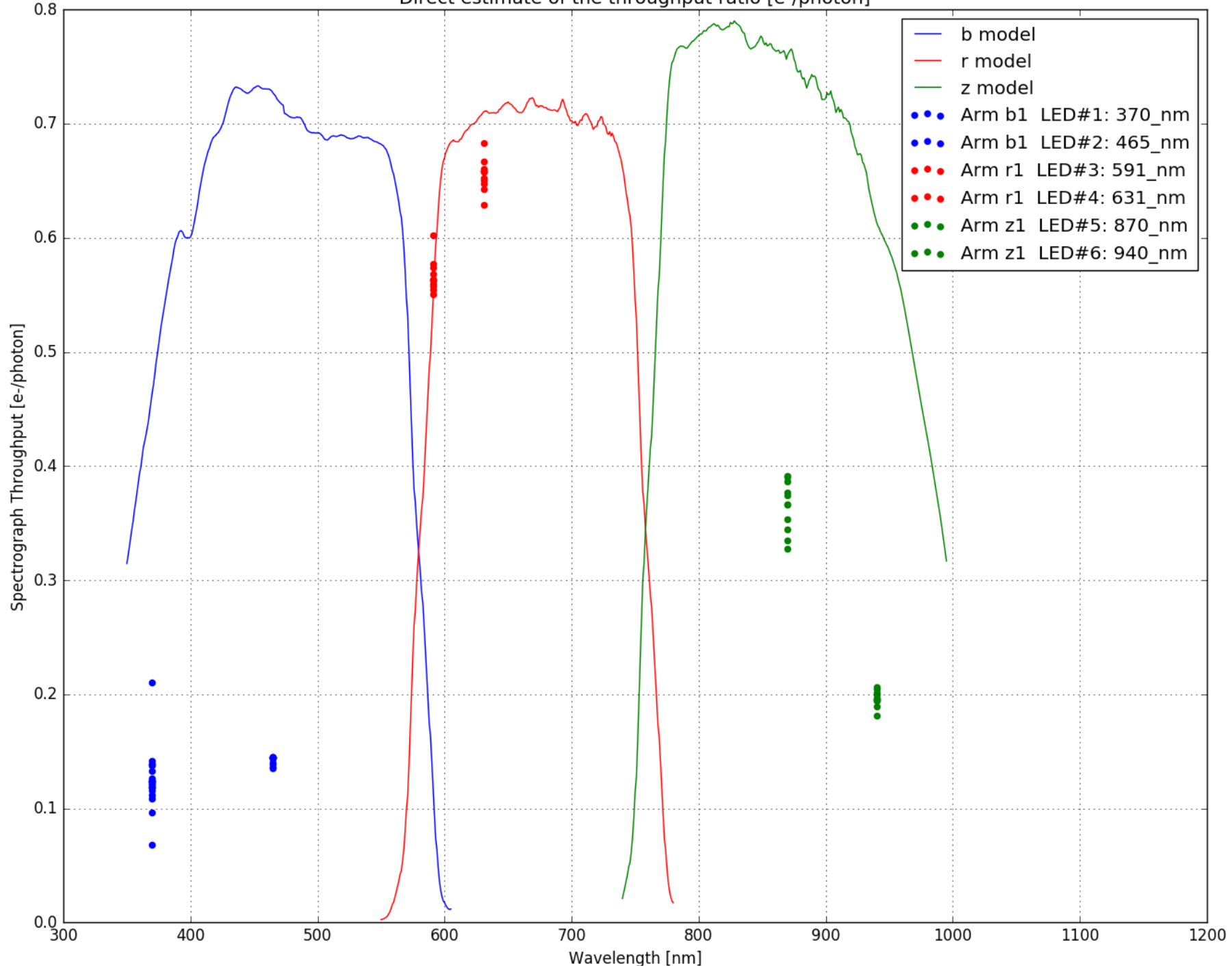

Direct estimate of the throughput ratio [e-/photon]

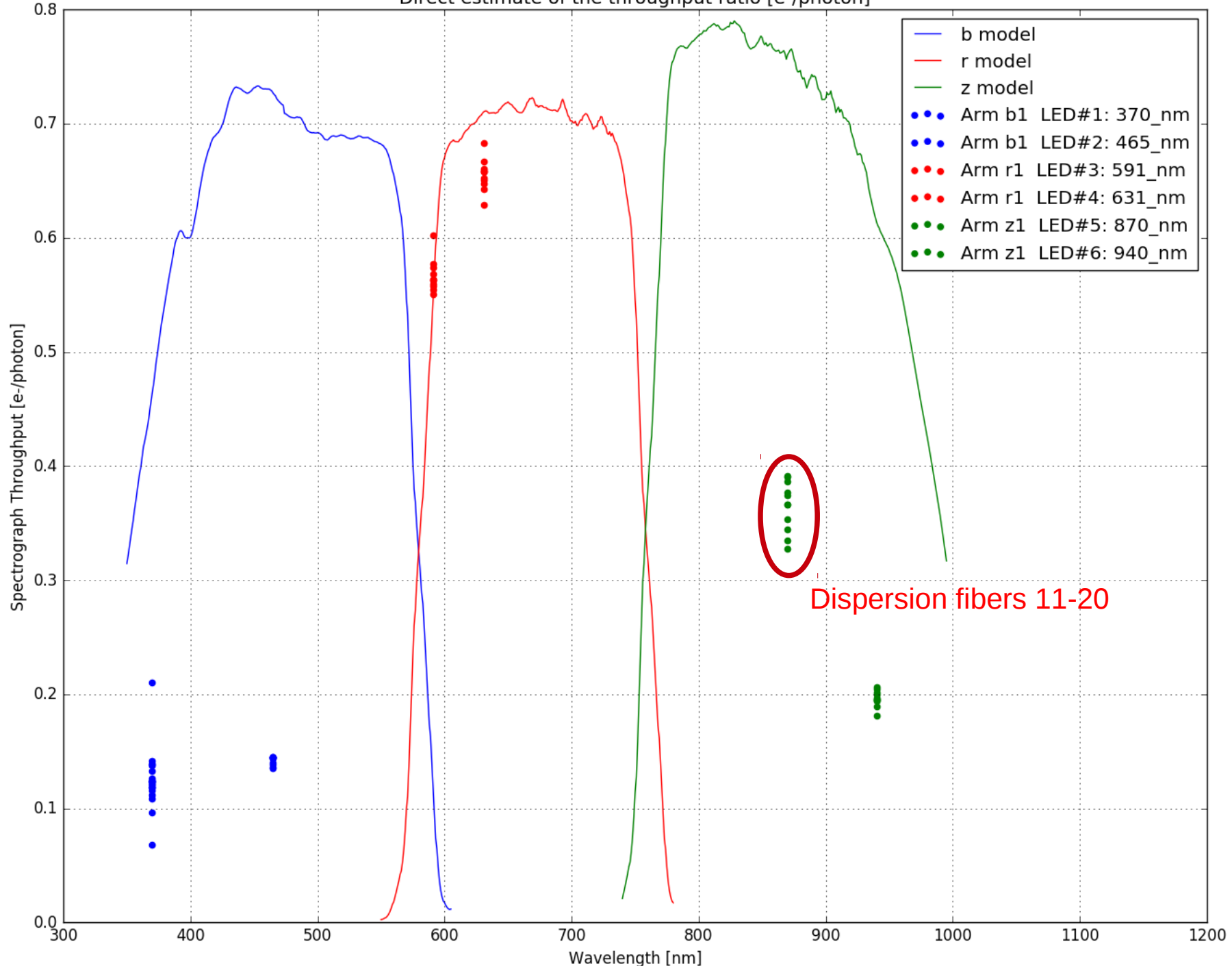

Direct estimate of the throughput ratio [e-/photon]

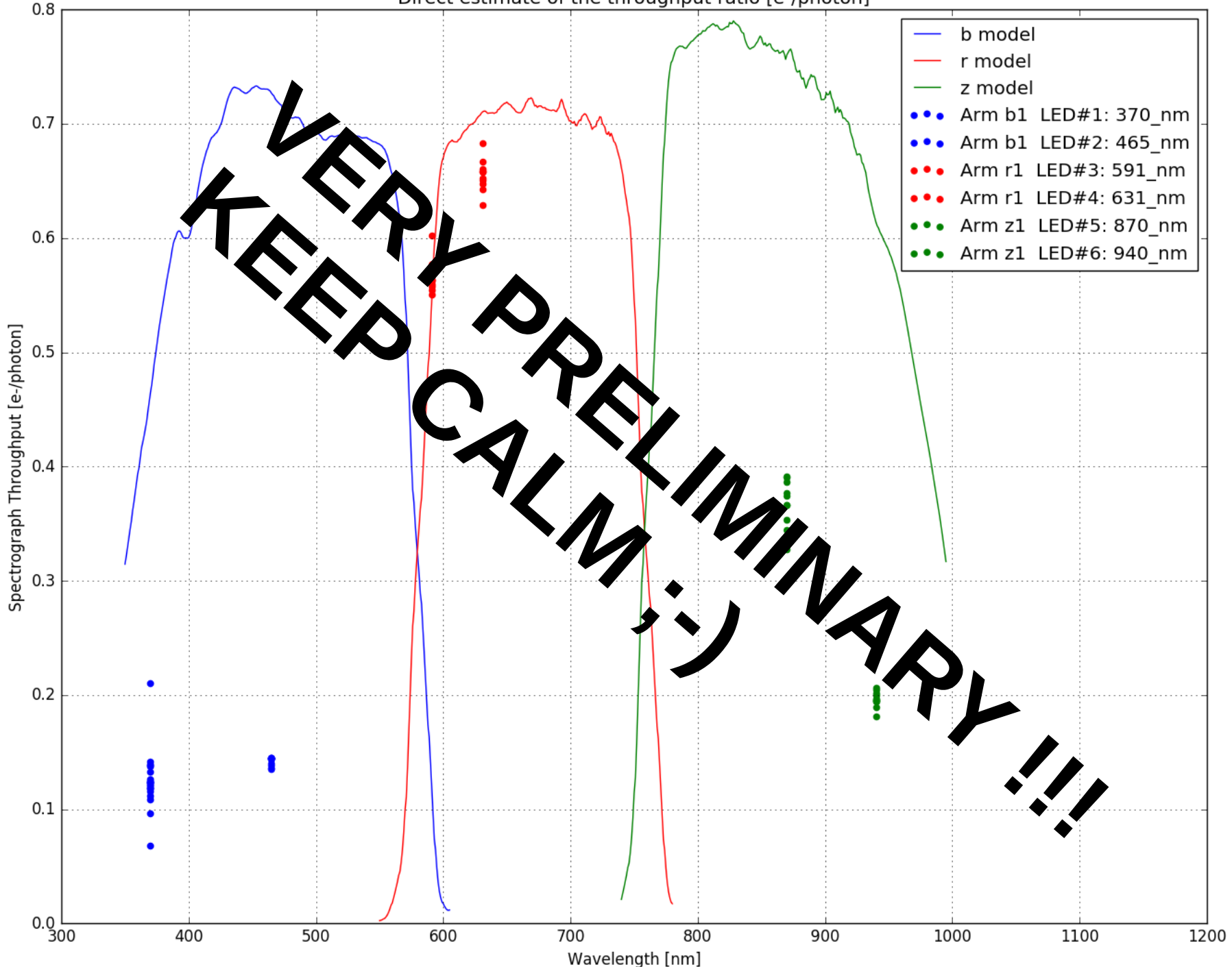



# Throughput shape from Tungsten lamp exposures

- Derived from Tungsten lamp exposures
- Hypotheses on Tungsten spectrum (blackbody, Thorlabs specs)
- Normalisation to be determined ! Gives the shape of the throughput function
- « Absorption » features : some are real and also seen in LED spectra (see below)

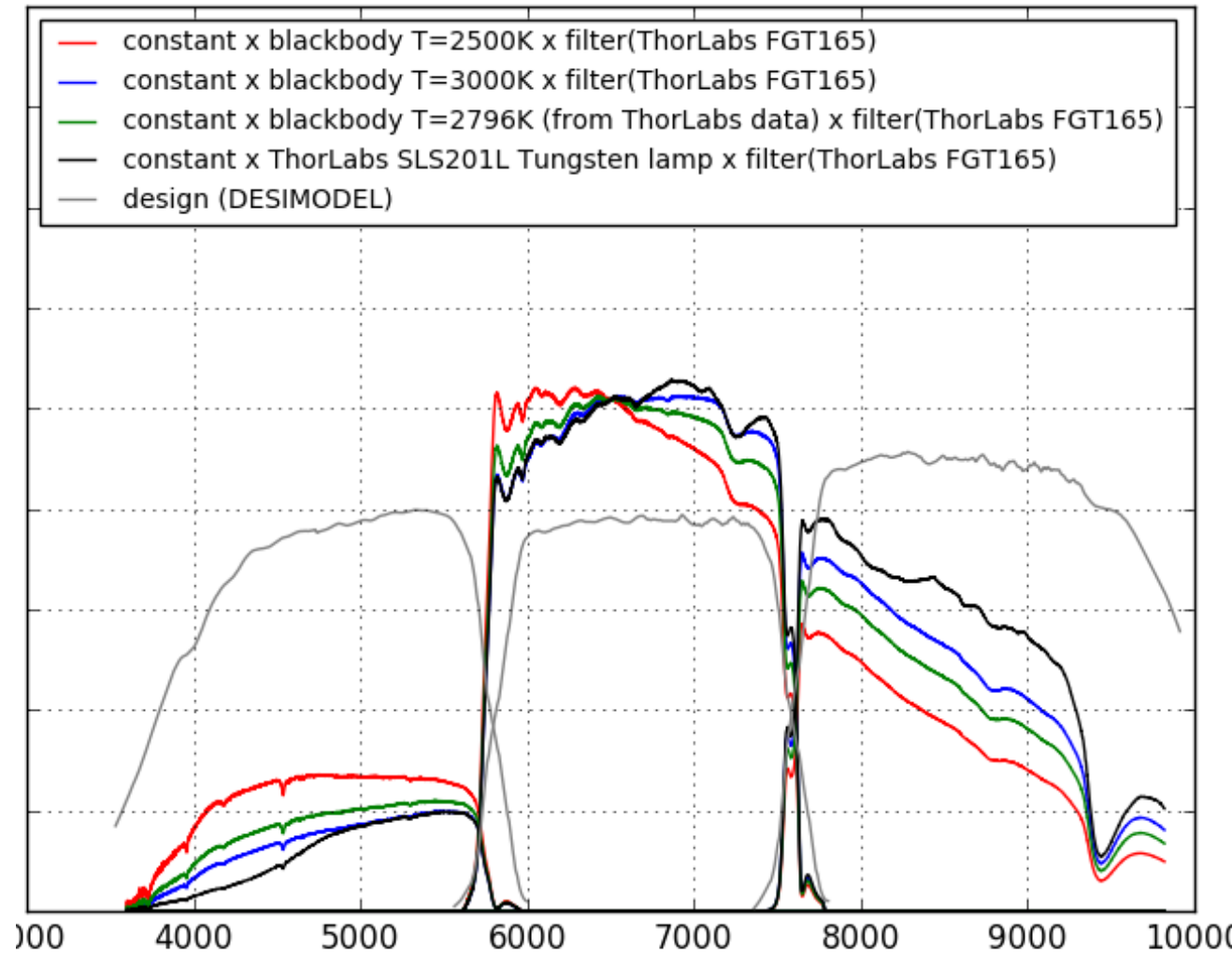

# Spectrum in DESI arm B1: LED#1: 370 nm

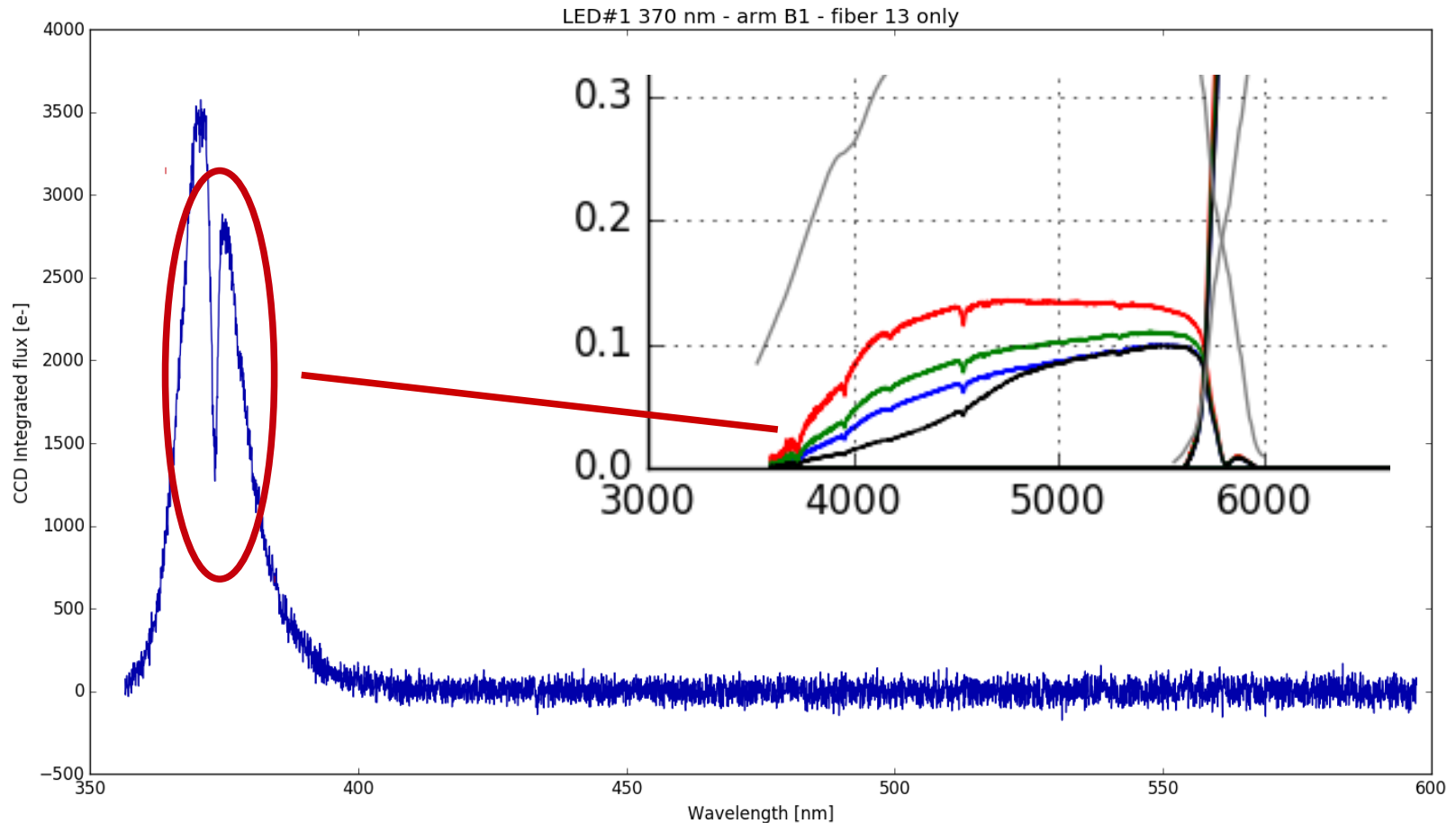

# Spectrum in DESI arm B1: LED#2: 465 nm

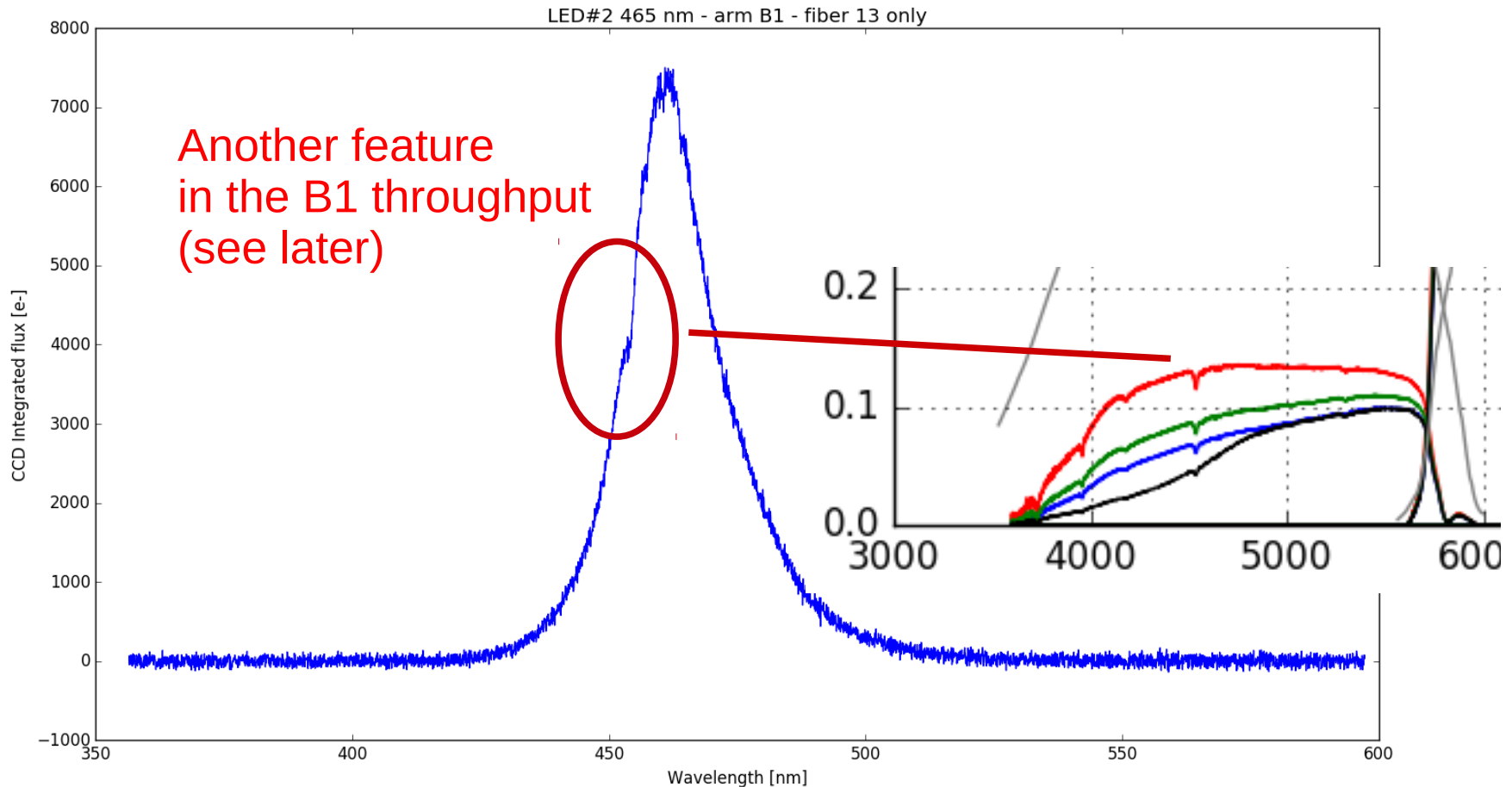

# Spectrum in DESI arm R1: LED#3: 591 nm

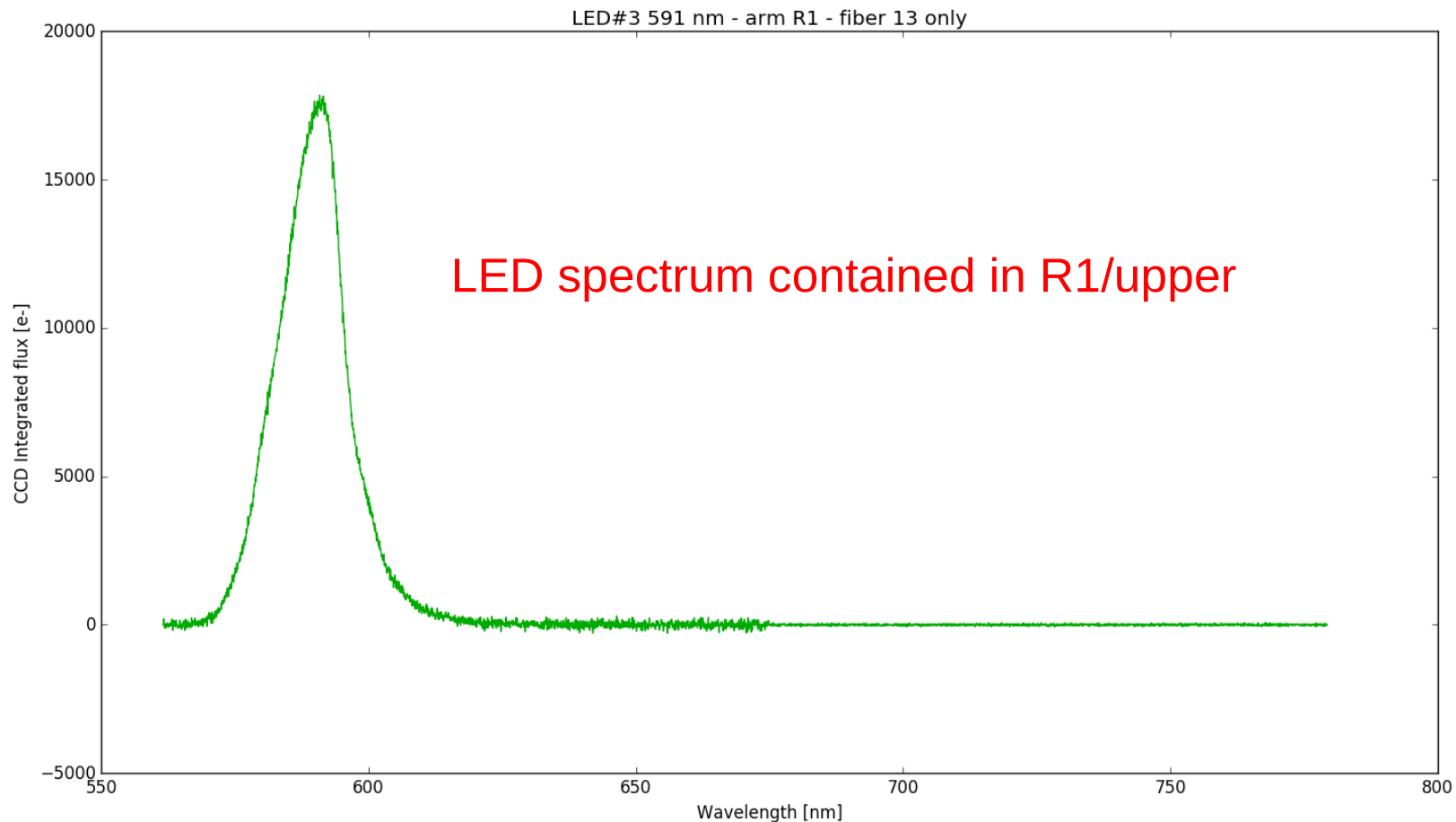

# Spectrum in DESI arm R1: LED#4: 631 nm

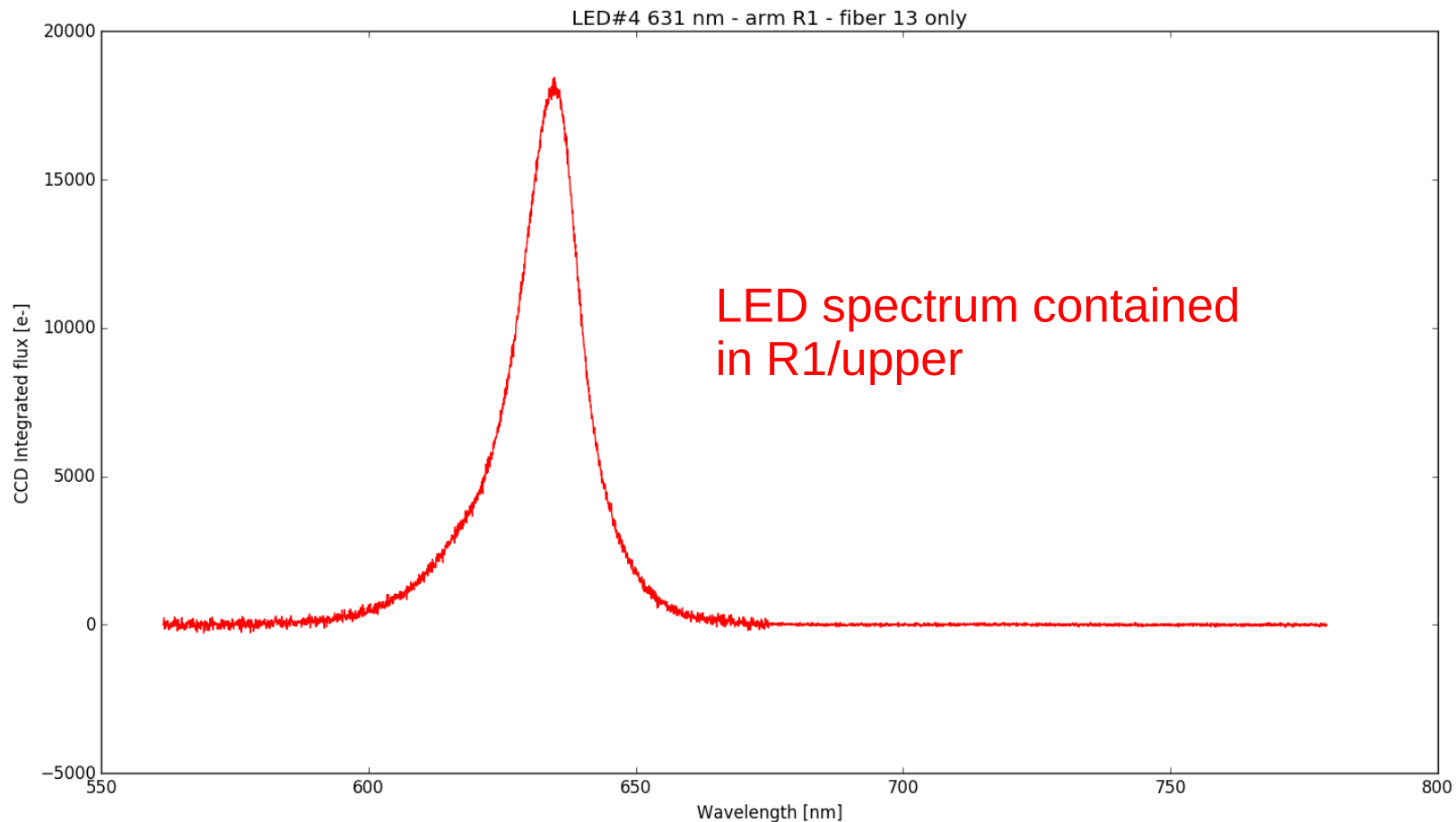

# Spectrum in DESI arm Z1: LED#5: 870 nm

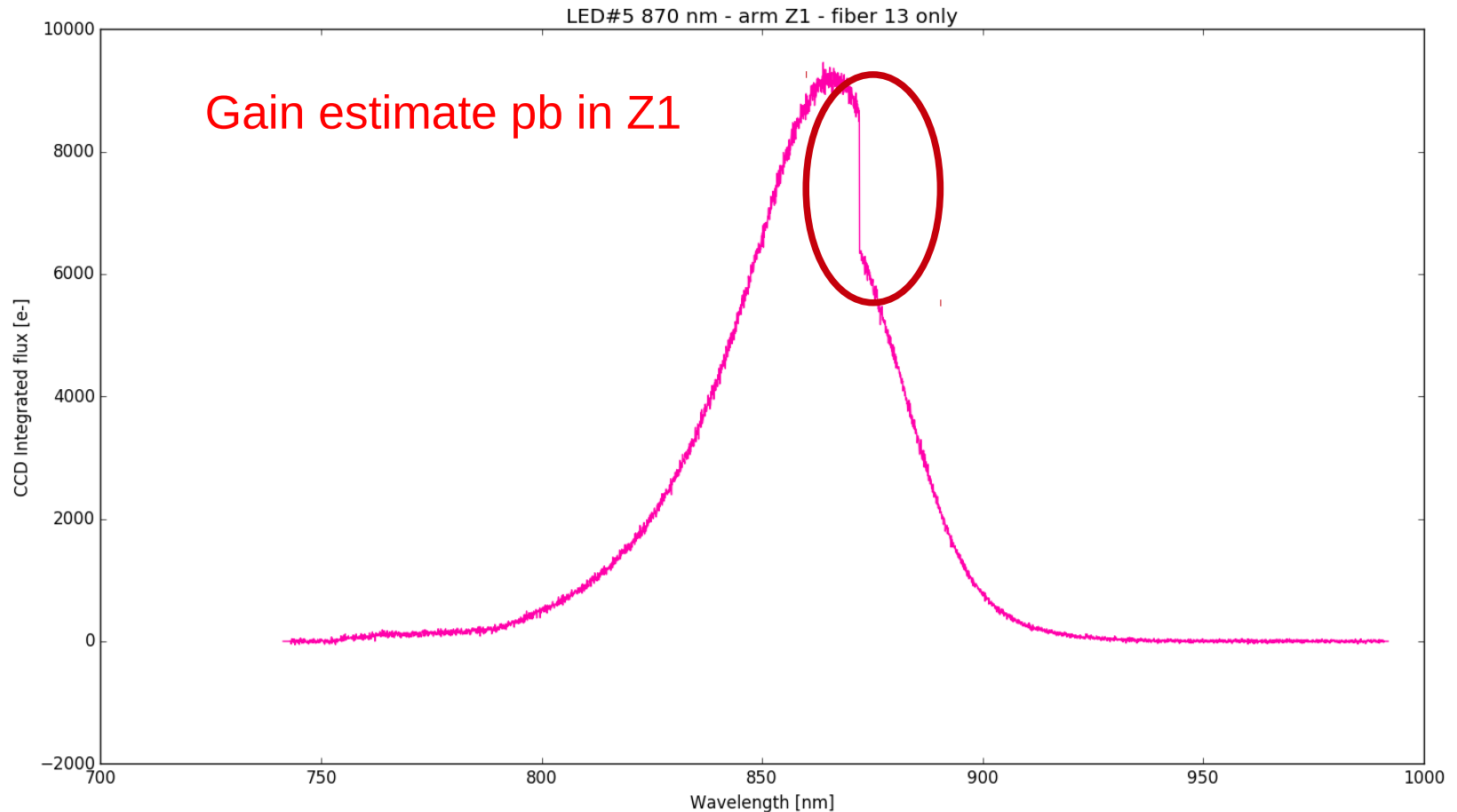

# Spectrum in DESI arm Z1: LED#6: 940 nm

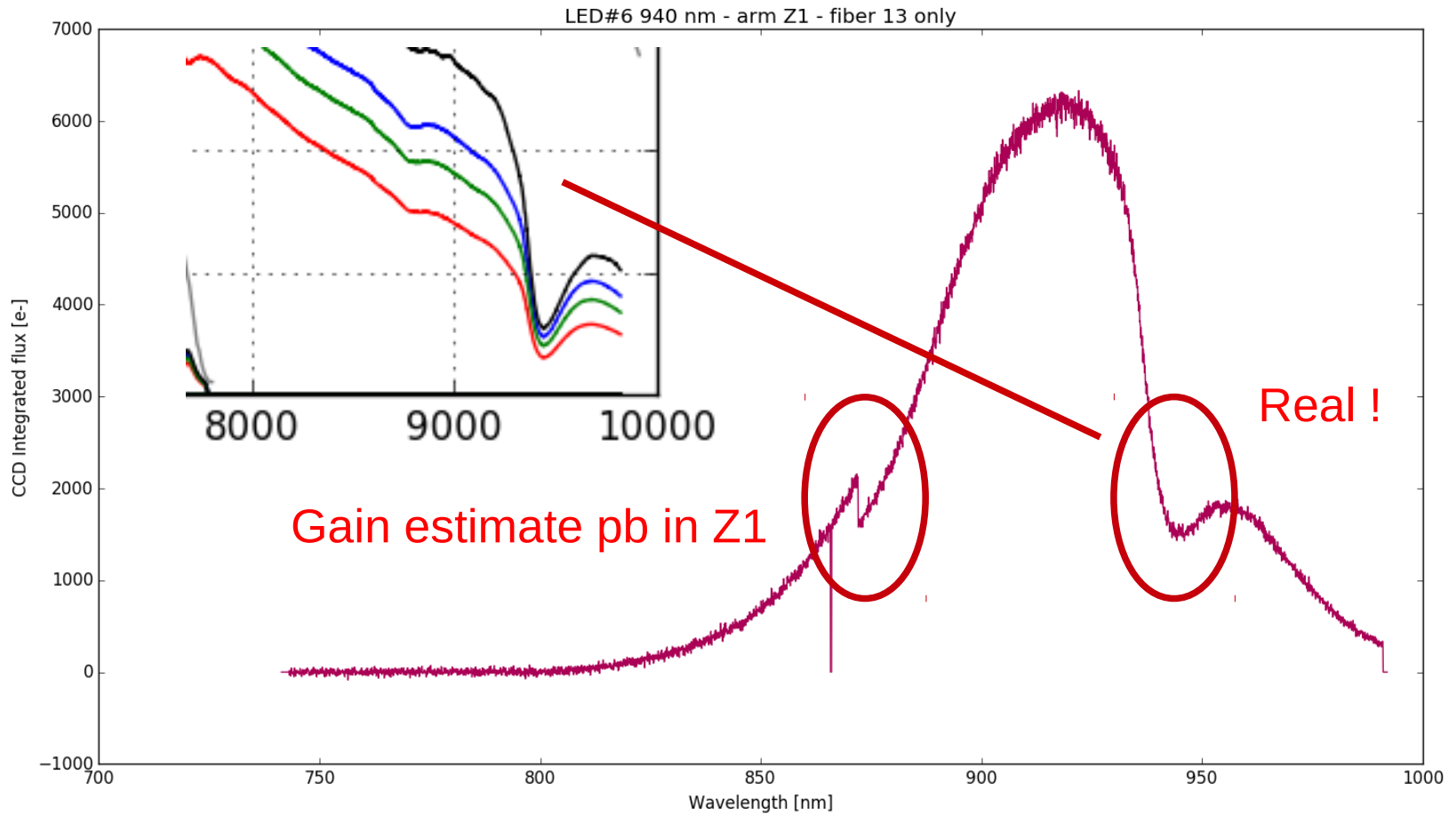

# Anchoring Tungsten to LED measurements

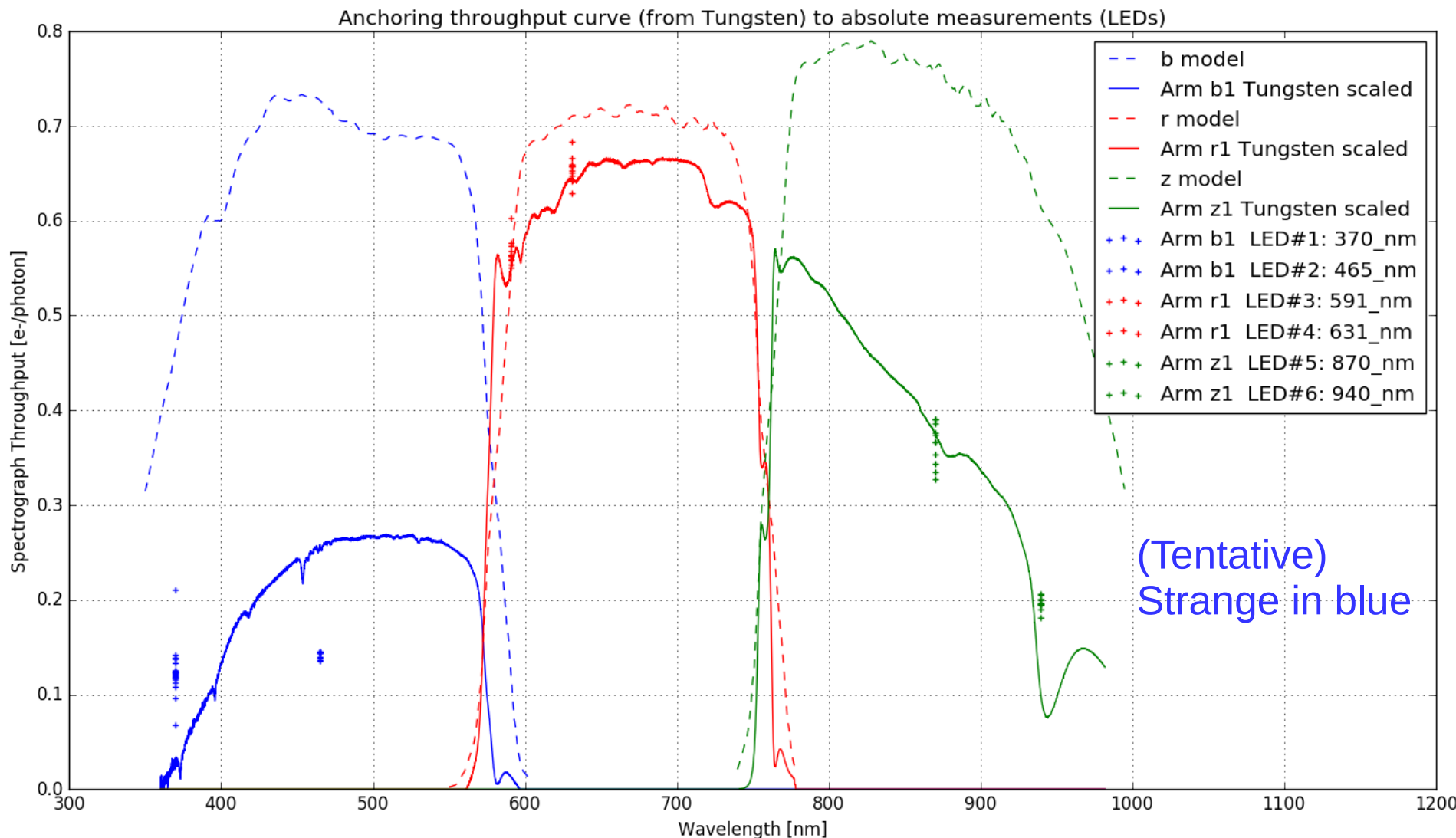



# Anchoring Tungsten to LED measurements

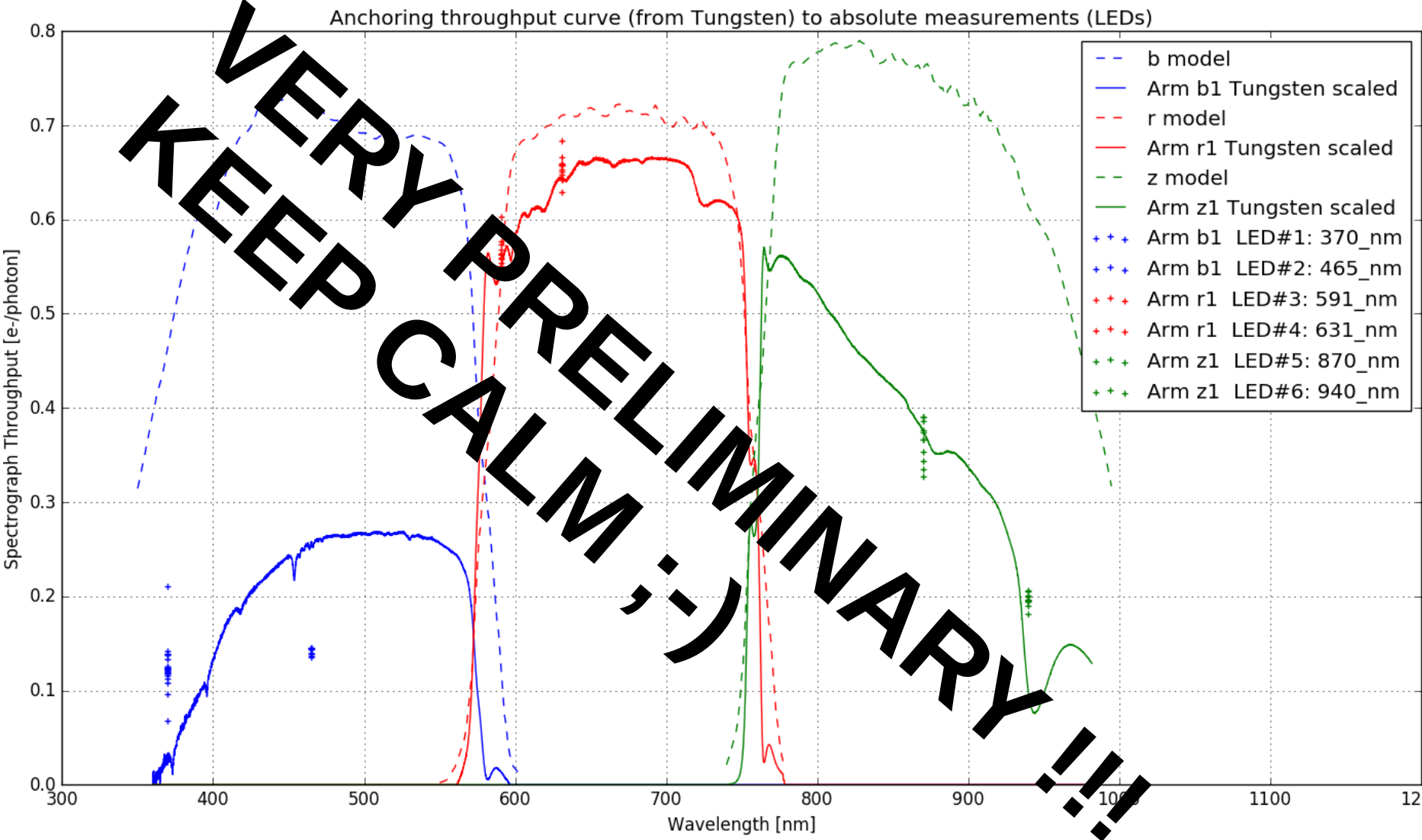

# With a model of the tungsten lamp spectrum

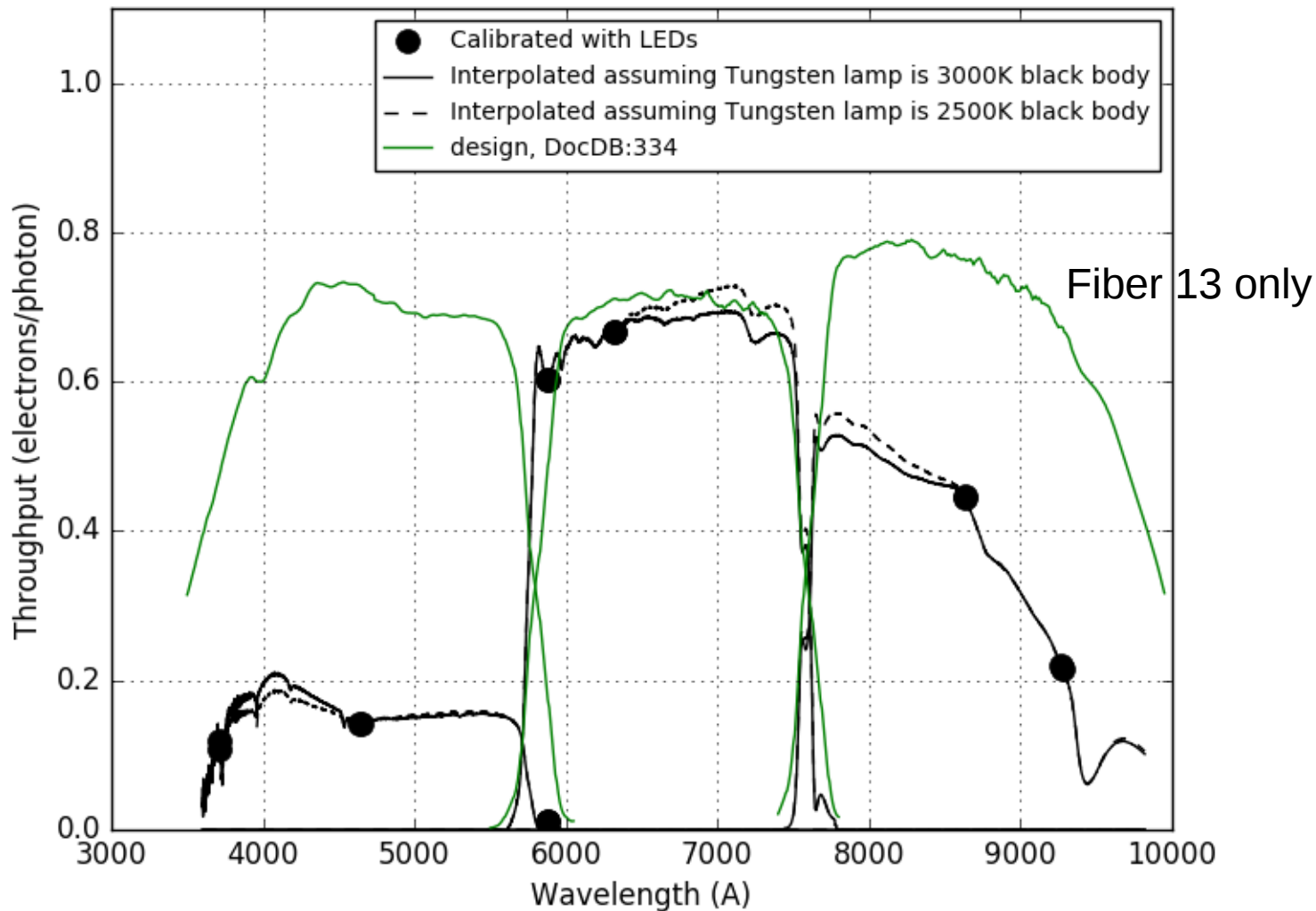

# With a model of the tungsten lamp spectrum

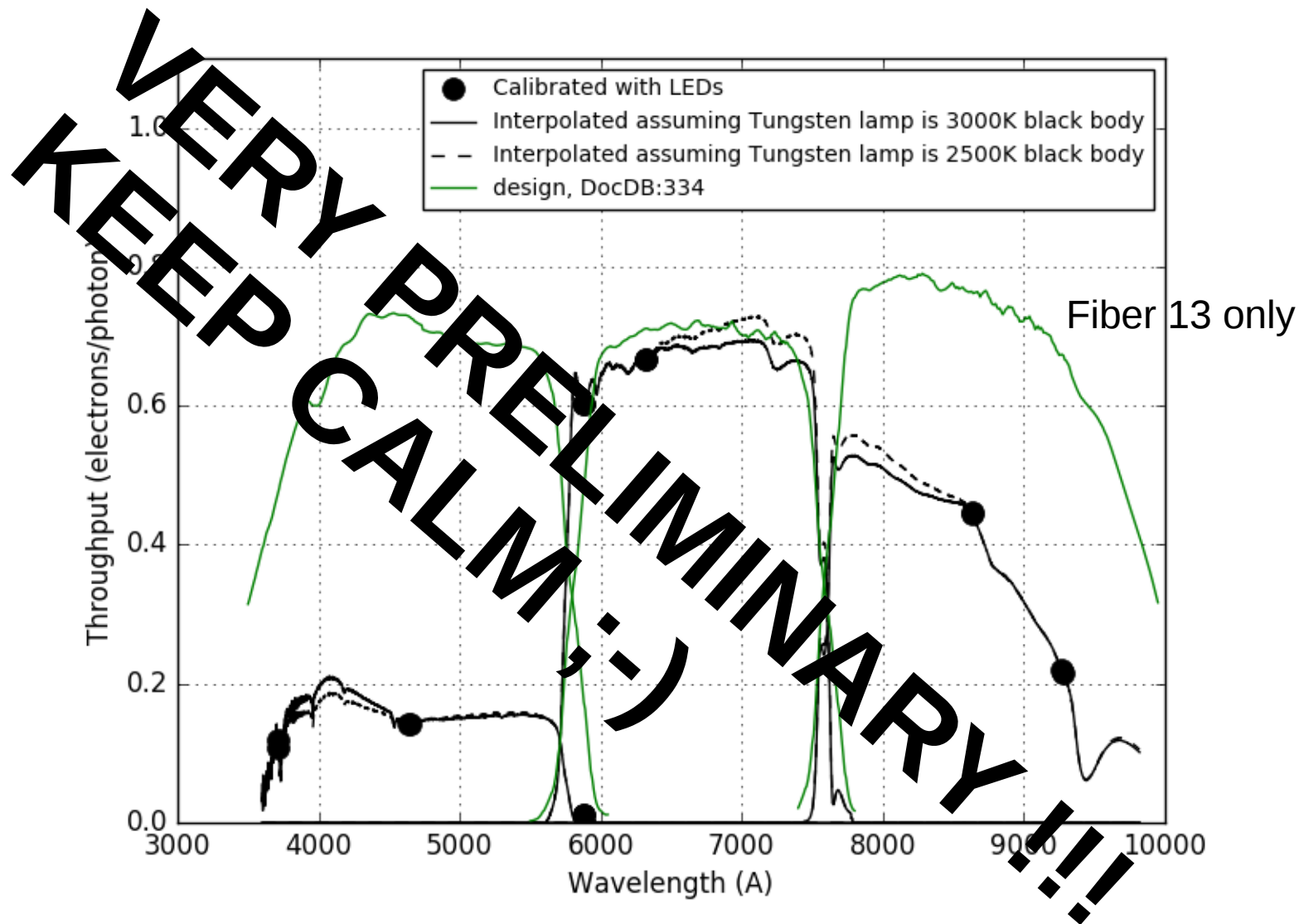

# Next: estimating the FRD from fiber beam scans

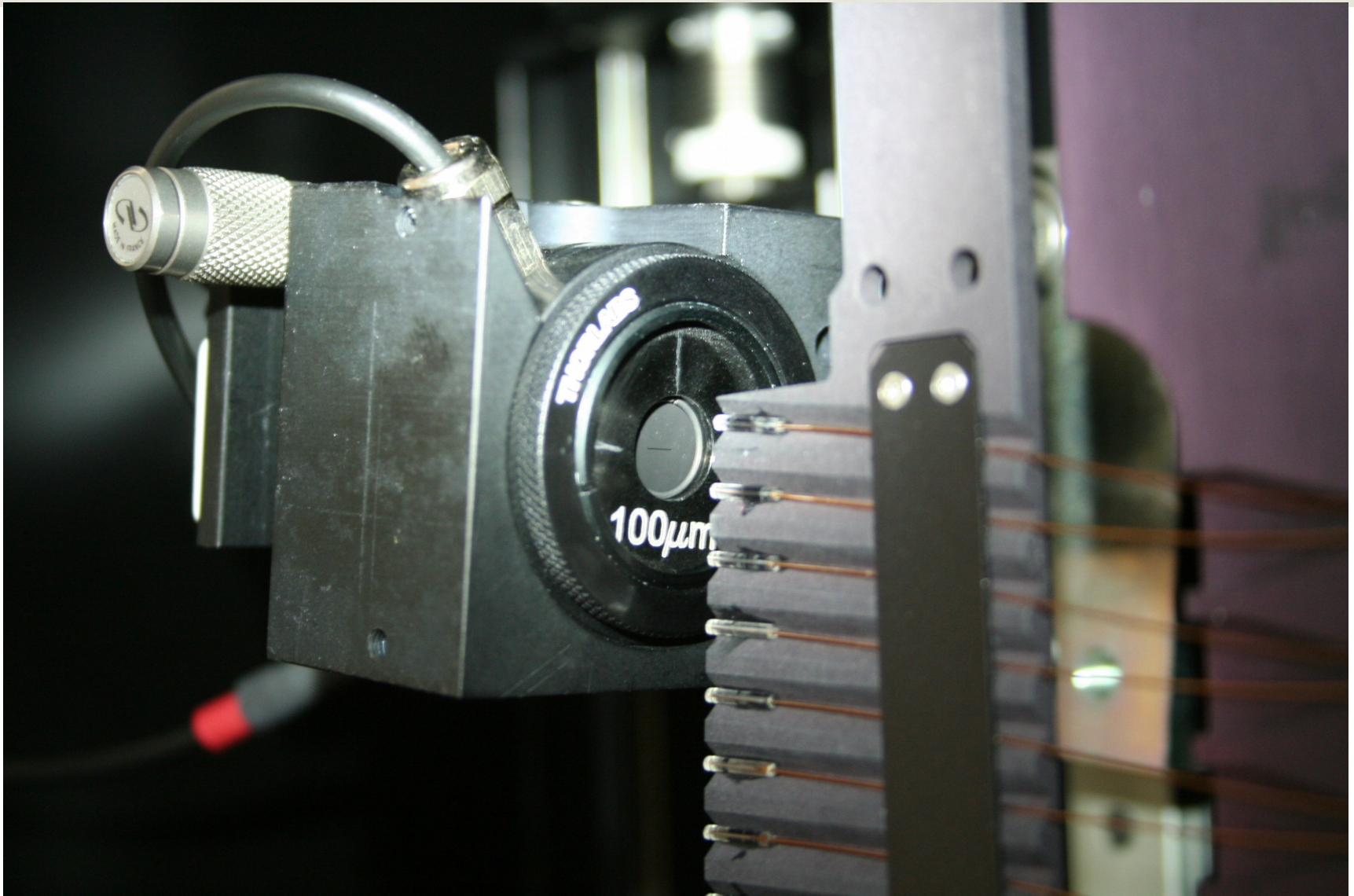

# Next: estimating the FRD from fiber beam scans

**Beam central occultation (convolved by the 100 microns slit)**

- Using the 100 microns slit scans to model the fiber exit beam
- Estimating the Focal Ratio Degradation from this dataset
- Scan shapes vary from fiber to fiber

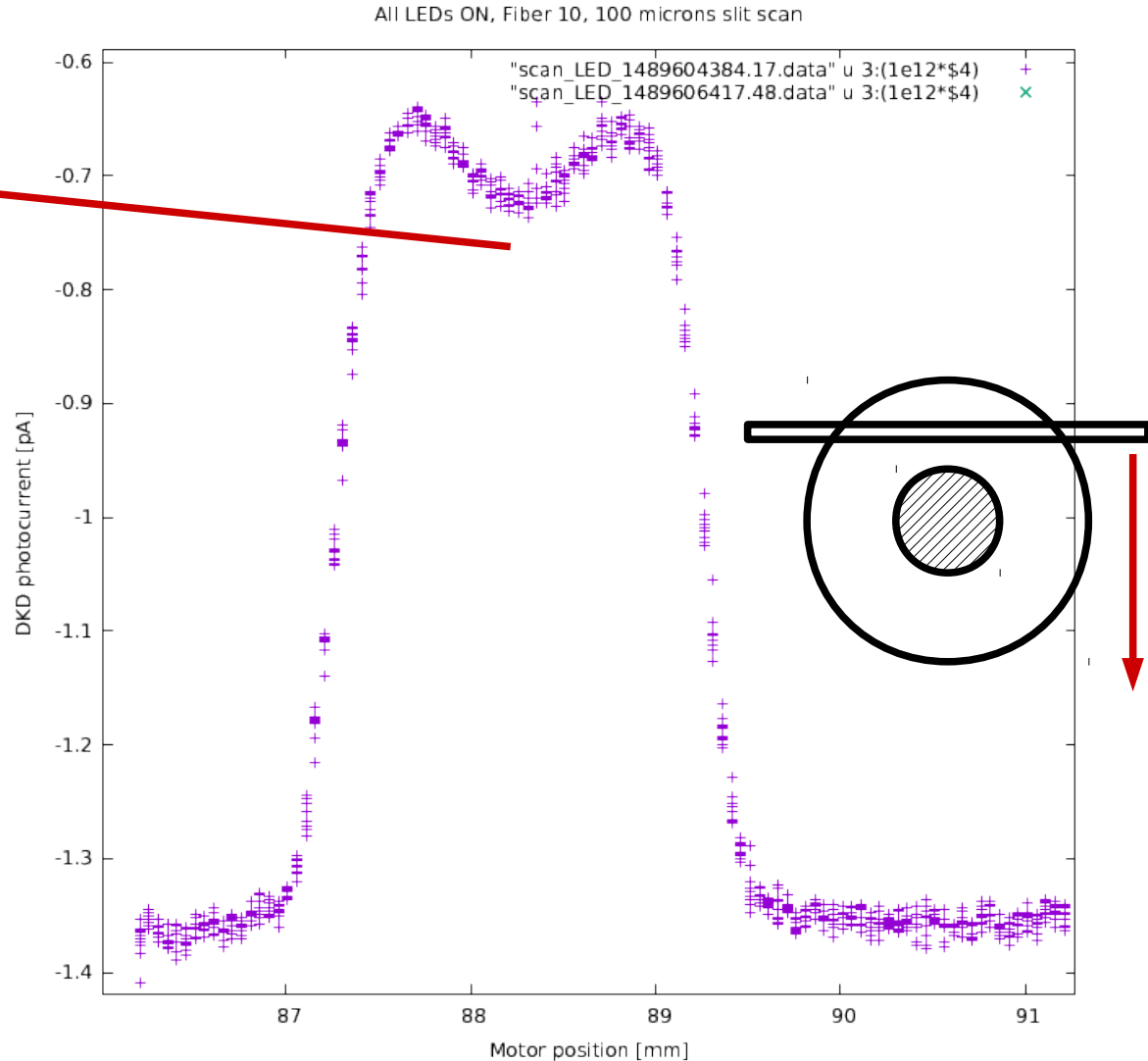

# Preliminary conclusions, and next steps

- ◆ Throughput measurement device **built, tested and installed on AMU testbench** at Winlight.
- ◆ **2 measurement campaigns in 2017.** Data analysis ongoing.
- ◆ Uncertainties on **gain measurements** (z1 highly non-linear); CCD of low quality.
- ◆ **Preliminary** results: indications of **low throughput in b1**
- ◆ **Focal Ratio Degradation (FRD) systematic** still to be estimated from **fiber beam scans** and a beam model.

