

Journal of the OPTICAL SOCIETY of AMERICA

VOLUME 28

JULY, 1938

NUMBER 7

An Experimental Study of the Rate of a Moving Atomic Clock

HERBERT E. IVES AND G. R. STILWELL
Bell Telephone Laboratories, Inc., New York, N. Y.
(Received April 12, 1938)

INTRODUCTION

IN previous papers in this series,¹ various consequences of the alteration of the rate of a clock in motion, which is an essential element in the theory of Larmor and Lorentz, have been discussed. In these papers, this change in clock rate has of necessity been treated as an assumption, since, up to the present time it has not been the subject of independent experimental verification. As was pointed out in these papers, the Michelson-Morley and Kennedy-Thorndyke experiments do not give the necessary information to establish the existence of this change of rate. An experimental search for this phenomenon is of particular interest, because the alteration of clock rate should be manifested as a *positive* effect, instead of the *null* effect characteristic of all other optical experiments.

The first suggestion as to a means by which this positive effect might be observed experimentally came from Einstein and from Ritz over thirty years ago, namely that the newly discovered Doppler effect in canal rays involved velocities of the moving particles high enough to show the expected effect. The experiment, whose crucial nature has been repeatedly emphasized, has been commonly imagined as performed by observing the canal rays at right angles to their

direction of motion, and for that reason, has been referred to as "the transverse Doppler effect." For hydrogen canal rays for velocities obtainable without difficulty in the laboratory, namely about 0.005 the velocity of light, a separation of several hundredths of an Angstrom unit is to be expected in the lines due to laterally observed stationary and moving particles.

The experiment, although recognized as of fundamental importance, has commonly been described as beyond experimental feasibility, chiefly for the reason that the light emitted by the moving canal rays in a tube of the conventional design does not consist of a single narrow line, but of a diffuse band altogether too wide to permit the detection of the small displacement indicated by theory (Fig. 1a). Furthermore, in the experiment as usually imagined, where the canal rays are supposed to be observed from the side, it would be extremely difficult to be sure that observation was made exactly at right angles to the direction of the rays, and very small deviations from this direction would introduce shifts of the order of magnitude of the expected effect.

The first of these obstacles to the performance of the experiment has been removed by the development by Dempster² of a type of canal-ray tube in which the velocities of the positive par-

¹ Herbert E. Ives, *J. Opt. Soc. Am.* 27, 177 (1937); 27, 263 (1937); 27, 305 (1937); 27, 310 (1937); 27, 389 (1937).

² H. F. Batho and A. J. Dempster, *Astrophys. J.* 75, 34 (1932).

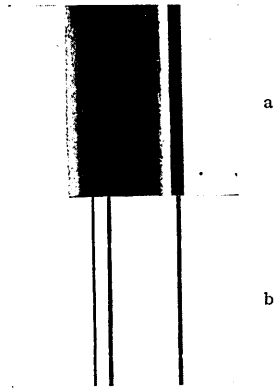

FIG. 1. Canal-ray spectra. (a) Undisplaced and displaced lines in tube of original type. (b) Undisplaced and displaced lines in tube of Dempster design.

ticles all lie within a very narrow range, so that the light emitted by them consists of a definite sharp line or lines (Fig. 1b). The second difficulty, above mentioned, can be avoided by observing not at right angles, but in two directions, with and against the motion of the particles; the observations being made simultaneously by the use of a mirror in the tube. Under these condi-

tions the displaced Doppler lines are observed corresponding to motion toward and away from the observer, and the effect to be observed is a shift of the center of gravity of the displaced lines with respect to the undisplaced line. As shown in an earlier paper of this series¹ this shift of the center of gravity is expressed by the equation $\lambda = \lambda_0(1 - V^2/c^2)^{\frac{1}{2}}$ where V is the observed or measured velocity of the positive particles.

APPARATUS AND METHODS OF OBSERVATION

The canal-ray tubes

The experimental test which forms the subject of this paper was performed with hydrogen canal rays, using the blue-green $H\beta$ line, of wave-length 4861 angstroms. The canal-ray tubes were designed along the general lines described by Dempster, as shown in Figs. 2, 3, and 4. The positive particles were produced in a hydrogen arc between the oxide coated filaments F and the grounded element of the double electrode A_1, B_1 , the discharge being constricted to the desired region by the shielding electrode D . The double electrode between which the accelerating field is

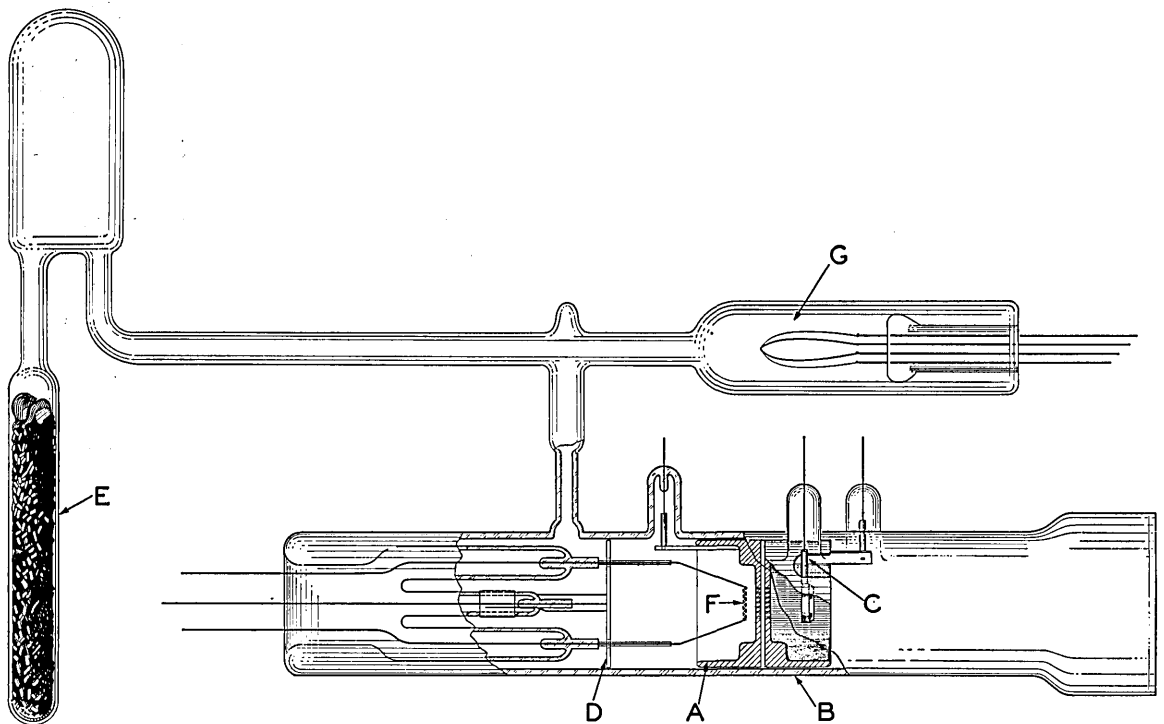

FIG. 2. Diagrammatic representation of canal-ray tube.

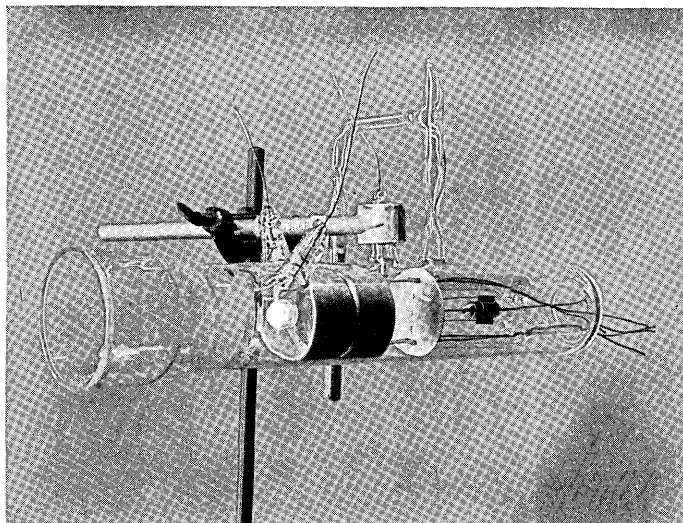

FIG. 3. Side view of canal-ray tube.

applied consists of two aluminum elements separated by 1.5 mm by quartz rod bushings which provide insulation and also hold the electrodes accurately parallel and in alignment. Both electrode units are drilled with 1 mm diameter holes to provide a positive ray beam approximately 1 cm square. The front surfaces and all edges of the accelerating plates are highly polished, to minimize the tendency to sparking which becomes quite bad when the higher accelerating potentials are used.

To one side of the perforations in the front electrode is placed a small concave mirror *C* made from an aluminum coated spectacle lens. The radius of curvature of this mirror is such that it will accurately image an object, such as the slit of the spectrograph, upon itself about 2 centimeters in front of the observation window. The observation window consists of a piece of plate glass fused onto the end of the tube. The small mirror is approximately 7° from the center of the perforations as viewed from its center of curvature. Because of the small rate of variation of the apparent velocity with angle near zero, no difference in apparent velocity of the canal rays as directly viewed and as seen in the mirror, as great as 1/100th of 1 percent can occur with the accuracy of imaging the spectrograph slit upon itself which was possible in the experiment.³

³ With this arrangement the real image which the mirror forms of the discharge is not coincident with the discharge

Hydrogen for the canal rays was stored in the side tube (*E*) containing activated charcoal. The gas pressure in the tube was controlled by the depth of immersion of the side tube in liquid air. The relative gas pressures were measured by the

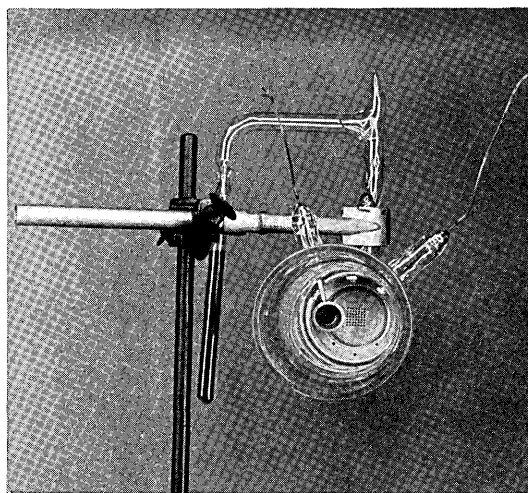

FIG. 4. End-on view of canal-ray tube.

but falls on the other side of the spectrograph slit. It was not believed that this lack of optical symmetry was important when weighed against the accuracy of alignment rendered possible. However, to test this point a tube was constructed furnished with a concave mirror which, by the aid of cross hairs in the discharge path, could be adjusted to image the discharge upon itself. This tube while more difficult to align accurately, gave identical results, as did also a tube with a plane mirror, so that any suspicion that the phenomena observed could be ascribed to optical dissymmetry is untenable.

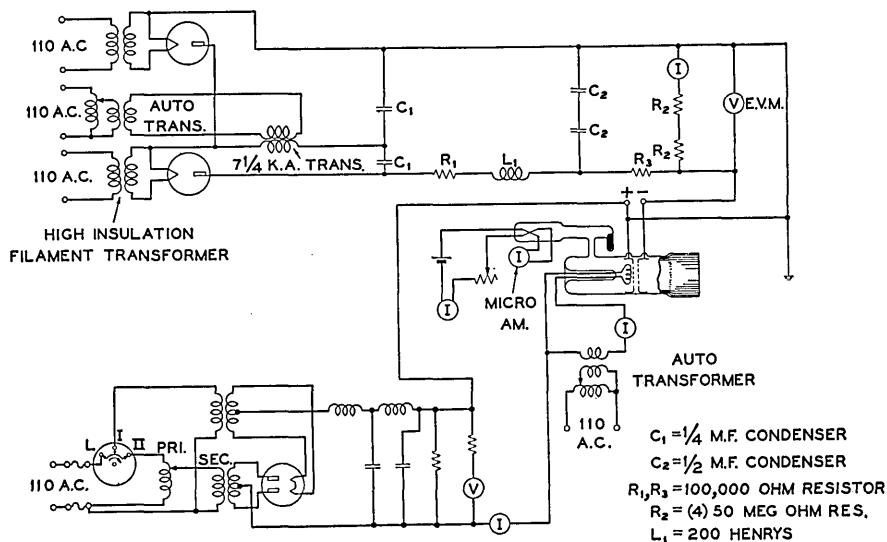

FIG. 5. Electrical circuits used with canal-ray tube.

gauge (G) which is a thermocouple gauge similar to one described by G. C. Dunlap and J. G. Trump;⁴ this manometer was previously calibrated against a McLeod gauge to read hydrogen gas pressures between 0.001 mm and 0.1 mm.

The whole tube with its attached charcoal reservoir was baked out while being pumped to eliminate any foreign gases, after which the filaments were activated. Hydrogen gas to a pressure of several millimeters of mercury was admitted to the pump station and the charcoal tube was partly saturated with hydrogen by immersing it part way in liquid air. The tube was then sealed from the pump station.

Electrical power supply and measuring apparatus

The low voltage hydrogen arc was maintained between the cathode (F) Fig. 2 and the grounded accelerating electrode (A) by an a.c. rectifier capable of delivering 400 milliamperes at 100 volts. Fig. 5 shows the electrical circuit diagram and how the connections were made to the canal-ray tube. This arrangement differs from that used by H. F. Batho and Dempster² and others, in that the hydrogen arc was maintained in a reverse direction between the first accelerating electrode and cathode instead of between the cathode and a third electrode. Experimentally

⁴G. C. Dunlap and J. G. Trump, Rev. Sci. Inst. 8, 37 (1937).

this method was found to give a more copious supply of positive ions just in front of the holes in the accelerating electrodes with a consequent brighter canal-ray beam.

The high negative potential applied to the accelerating electrode (B) was maintained by an alternating current rectifier capable of delivering up to 30,000 volts d.c. Fig. 5 shows the diagram of the electrical circuit used which is essentially a voltage multiplying circuit. The transformers and associated equipment were selected to have a much greater power rating than was necessary for the performance of this experiment thereby insuring greater steadiness of operation and decreasing fluctuations of the output voltage. The rectified voltage was smoothed by the filter network combination (R_1), (L_1) and (C_2) and fed to the canal-ray tube through the limiting resistance (R_3). The applied d.c. voltage was indicated on a high resistance voltmeter consisting of four 50 megohm resistances (R_2) in series with a zero to one hundred full scale microammeter. The resistors were especially made physically large to have very small temperature coefficient for the small current values used. The resistances were measured and the meter calibrated to read within an accuracy of one percent.

Since it was important in this experiment to hold the applied accelerating potentials very

steady during long photographic exposures an additional voltage reading technique was employed which greatly facilitated the observation of small voltage fluctuations. This consisted of a Wülf electrostatic voltmeter whose sensitivity could be varied with the applied voltage being used. The deflected reed and illuminated scale indicating the applied voltage was projected, greatly enlarged, onto a screen across the room. The sensitivity of this arrangement could be adjusted so that 1/10 of one percent of the voltage indicated by the resistance voltmeter could be easily detected.

Voltage adjustments were made by means of a manual control in the primary circuit of the high potential transformer; this control included a variac step-down transformer and series resistance.

The spectrograph

The dispersing element of the spectrograph used was a metal on glass plane grating made by Professor R. W. Wood. This is approximately 7 inches in diameter with ruling of 15,000 lines to the inch, with grooves so controlled as to throw a very large part of the total light into the first order on one side. In conjunction with the grating were two high quality telescope objectives of approximately 5 feet focus. The grating was mounted at right angles to the axis of the telescope element, under which conditions a normal spectrum is obtained.⁵ The whole spectrograph was constructed as a rigid iron box of exactly the

dimensions to bring the H β line in the middle of the photographic plate. An accurate bilateral slit was mounted so as to be rotatable about its center point with great exactness. Behind the slit was a pivoted observing telescope and extended light source behind a transparent mirror. By observation with this microscope the orientation of the canal-ray tube and its small mirror could be made with extreme accuracy, the adjustment being complete when upon rotation of the slit its reflected image remained exactly coincident with it.

The whole spectrograph was mounted on a heavy steel framework which was arranged to be capable of rotation about a vertical axis, and the apparatus as a whole was placed on a layer of anti-vibration material in a basement room which was thermostatically controlled to hold to a temperature to within 1/10th of a degree centigrade. The arrangement of the apparatus is shown schematically in Fig. 6, and in the photograph, Fig. 7.

A number of appropriate adjusting means were provided, including screw adjustments for translation and rotation of the canal-ray tube, visible in the photograph, Fig. 8. A sighting aperture and telescope were arranged at the collimator lens, by means of which the placing of the mirror in the canal-ray tube so that it was in line with the optical axis of the spectrograph was assured by preliminary adjustment before the use of the microscope at the slit. A small slowly rotating variable sector was provided in front of the photographic plate by means of which the exposures of the various canal-ray lines could be equalized.

Measurement of the spectrograms

The dispersion of the spectrograph was 10.87 angstrom units per millimeter. The displacement due to the Doppler effect for H $_2$ in the neighborhood of 20,000 volts is about 2 millimeters; the expected shift of the center of gravity of the displaced lines (directly viewed and reflected in the mirror) is about 0.05A or 0.005 mm. This made it desirable to have means for measuring the spectrograms with an accuracy at least 0.001 mm. The measuring microscope used was a Carl Zeiss instrument furnished with a special large diameter reading drum, on which 0.001 mm

⁵ A test for the normality of the spectrum produced by the grating-lens combination was made on three lines of the molecular spectrum of hydrogen covering a range of 250A approximately centered about the H β line, namely 4719.01A, 4849.32A and 4973.26A. The following figures were obtained for the quantity A/mm:

Interval		A/mm
4719.01-4849.32A	Plate A, measured upward on screw	10.870
	downward " "	10.875
	Plate B, " upward " "	10.876
	downward " "	10.877
	Mean	10.874
4849.32-4973.26A	Plate A, measured upward on screw	10.877
	downward " "	10.874
	Plate B, " upward " "	10.872
	downward " "	10.870
	Mean	10.873

A hyperbolic deviation from linearity, such as would produce an apparent shift of the center of gravity of the magnitude in question in this investigation would mean a difference of 0.5 A/mm in the quantity for the two wavelength ranges measured.

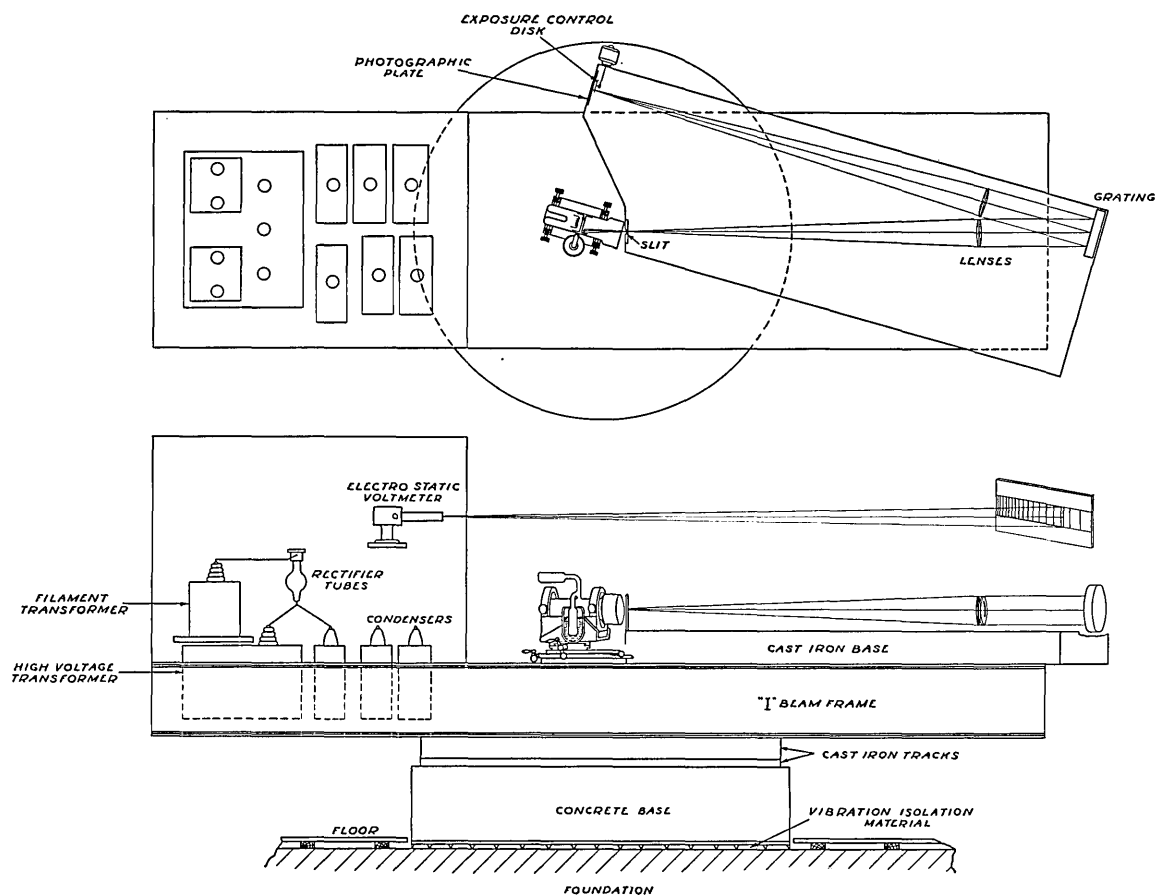

FIG. 6. Plan of apparatus.

could be read directly, and tenths of divisions estimated. The accuracy of the screw was not however to be relied upon for better than 0.001 mm, and so a special measuring procedure was employed, made possible by the approximately symmetrical character of the pattern presented by the displaced lines. A series of measurements were made of separations of the displaced lines from the center, undisplaced line, the latter being accurately located at a chosen point on the screw. The plate was then turned end for end, the center line again placed accurately on the same chosen point of the screw, and the separations remeasured. This procedure was then repeated at several points on the screw, and the mean values of the several series were used. The probable errors of the final values so obtained were found by analysis of the measurements to be about 0.0025A.

OBSERVATIONS

Characteristics of the canal rays

Typical spectrograms obtained in the investigation are shown in Fig. 9. In each the center, undisplaced line is seen, accompanied at either side by two companions, which, by their separations from the center line by distances in the ratio $\sqrt{2}/\sqrt{3}$ are identified as H_2 and H_3 , or double and triple atomic hydrogen. No H_1 particles were found in this work.

A fundamental assumption in this experiment is that the light emitted by the excitation of the stationary particles in the tube, and by the excitation of the multiple mass traveling particles, is (except for the predicted second-order change), of the same frequency. Put in another way, the assumption is that in every case the emission is that of the single excited hydrogen atom, to which all the particles must be assumed

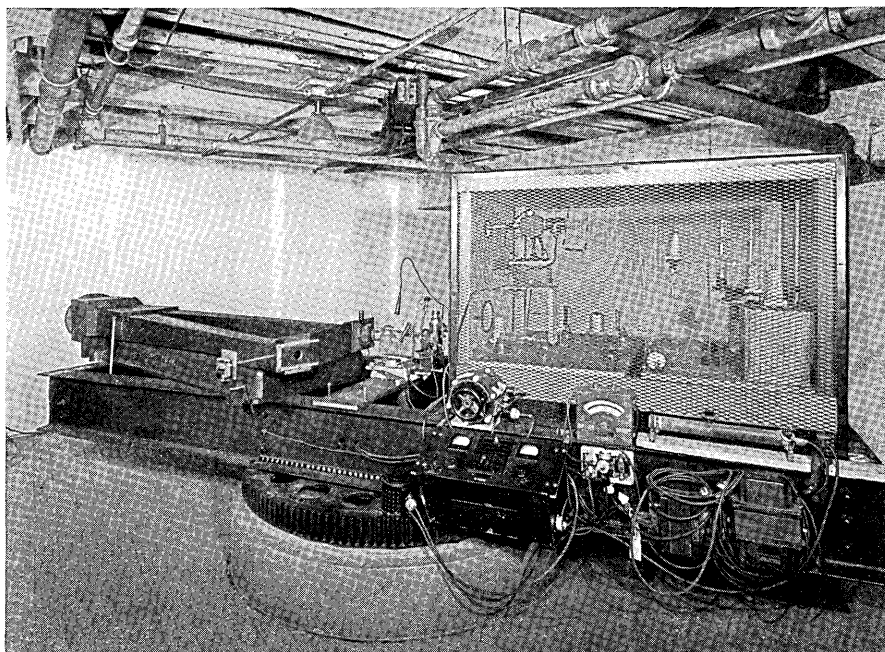

FIG. 7. Photograph of apparatus.

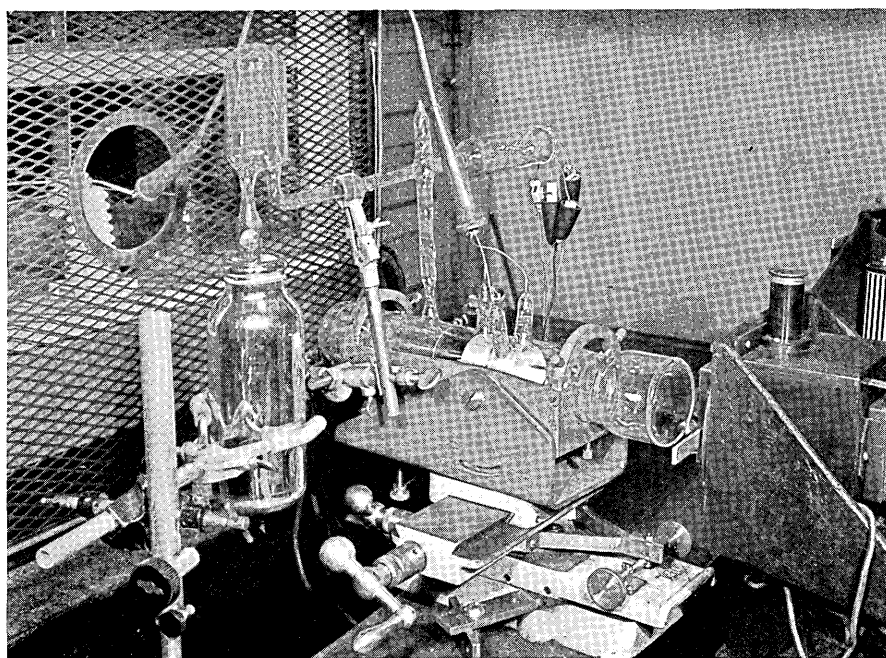

FIG. 8. Tube in place.

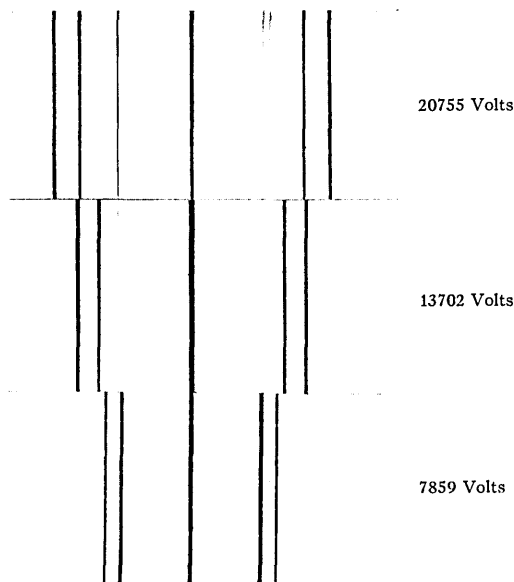

FIG. 9. Spectrograms obtained for several applied voltages.

to revert before emitting light. There is no experimental or theoretical reason for expecting this not to be the case, at least to a high order of approximation, although very considerable changes in the relative intensities and sharpnesses of the canal ray lines occur over the range of voltages and pressures used in this experiment. Thus the center, undisplaced line is very weak, relative to the displaced lines, at voltages below 3000, but is quite sharp. At voltages of 10,000 and over the center line becomes diffuse but with a sharp central core, and is much more intense than the displaced lines. (These differences in intensity do not show in the spectrograms, Fig. 9, as these were made with the variable sector adjusted to equalize the exposures.) At low gas pressures (below 0.005 mm Hg) the H_2 lines are brighter than the H_3 ; at higher pressures H_3 becomes relatively more intense. The $H\beta$ line is actually a close doublet, of separation 0.09\AA , but always appeared single and symmetrical in our spectrograms. The possibility of a varying distribution of intensities between the components is not excluded.

In default of evidence to the contrary the assumption above stated has been taken as valid in carrying through the experiment but with recognition of the obligation to scrutinize the final results carefully for any indications that

they are significantly affected by the collision and their processes active in the discharge.

Preliminary measurements and choice of conditions

The first measurements made on the spectrograms were used to check the theoretical relationship

$$eE = \frac{1}{2}M(V^2/c^2)$$

when E is the voltage between the electrode plates, e the charge on the hydrogen atom, and M the mass of the particle observed. V/c as obtained from the ratio $\Delta\lambda/\lambda$ should agree with the value obtained from the above formula.

In Fig. 10 are shown, by the dashed lines, the computed values of $\Delta\lambda (= \lambda_0(V/c))$, for H_2 and H_3 , plotted against the square root of the voltage; and by the marked points, the observed values of $\Delta\lambda$ at seven voltages, selected as described in a later paragraph. These "observed" values are the mean measured displacements of the direct and reflected Doppler lines, increased in the ratio $1/\cos 7^\circ$, where as previously described, 7° is the angular displacement of the concave mirror from the axis of the beam. This gives the displacement for observation exactly along the beam, which is the quantity directly derived from the fundamental relationship between voltage and velocity, and is the quantity with

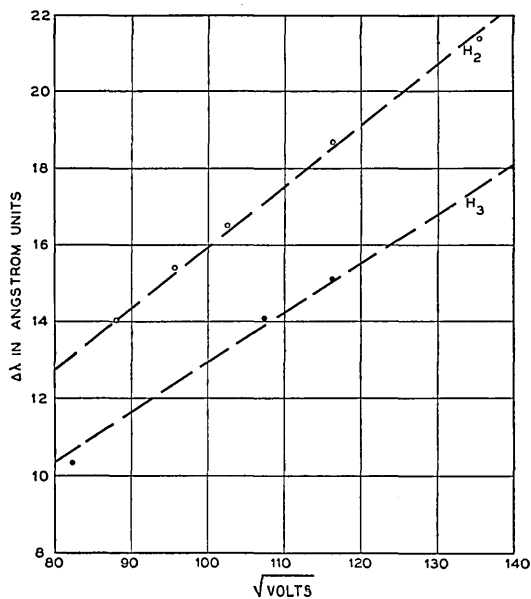

FIG. 10. Computed and observed Doppler displacements.

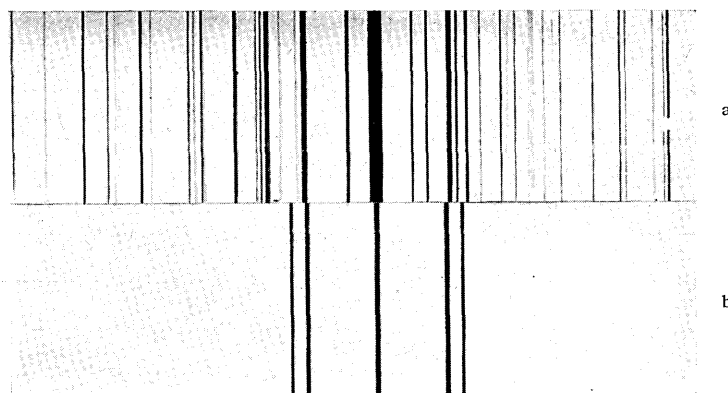

FIG. 11. (a) Molecular spectrum of hydrogen in the neighborhood of $H\beta$. (b) Canal-ray spectrum for voltage selected to make H_2 lines clear molecular lines.

which the second-order shift is theoretically correlated. The data used in plotting Fig. 10 are assembled in Table I. It will be seen that the observed Doppler displacements show no systematic deviations from the computed and agree with these in general to within about 1 percent.

The next measurements were those to detect and measure the shift of the center of gravity, if existent, of the directly observed and reflected lines. The first measurements revealed very erratic and confusing displacements, which showed no systematic relationship with the orientation of the apparatus or other known variables. The source of these unsystematic shifts of the center of gravity of the displaced lines was found to lie in the presence of faint lines of the second or molecular spectrum of hydrogen. A few lines of this spectrum are obviously present, at the highest voltages, at positions other than those occupied by the canal-ray lines as shown in Fig. 9. However, upon photographing the spectrum of the arc behind the electrodes (Fig.

11) or upon very long exposure of the canal-ray spectrum, a large number of these second spectrum lines appear. While very faint and under exposed in the canal-ray pictures, these lines were found, if they fell close to or partially over the canal-ray lines, to shift the position of these latter enough to vitiate the measurements.

The next step was then to plot the positions of the second spectrum lines with the object of finding which voltages could be used to place the canal-ray lines in clear spaces, in Fig. 12 is shown a plot of the chief second spectrum lines in the neighborhood of the $H\beta$ line, the lines on both red (dashed) and blue (full) sides being plotted together. On the same plot are shown the displacements of the canal-ray lines against the square root of the voltage as measured. Plotted in this way the H_1 , H_2 and H_3 Doppler displacements fall on straight lines. As can be seen, the number of available voltages for securing pairs of direct and reflected lines in clear spaces is limited.

After picking voltages corresponding to satisfactorily clear spaces, the next experiments were made with sufficiently rapid plates to make possible obtaining exposures in about one hour. These plates were of too coarse grain for measurements of the highest accuracy, but the short exposure time was desired in order to investigate whether there was any effect due to the orientation of the apparatus with respect to the earth's motion. A series of plates were made, as shown in Table II, with the apparatus pointing

TABLE I.

PLATE	VOLTAGE	LINE	$\lambda_0 V/c$ COMPUTED	MEAN $\Delta\lambda$ OBSERVED ($\Delta\lambda/\cos 7^\circ$)
169	6,788	H_3	10.62A	10.35A
160	7,780	H_2	14.04	14.02
163	9,187	H_2	15.30	15.40
170	10,574	H_2	16.34	16.49
165	11,566	H_3	13.88	14.07
172	13,560	H_2	18.50	18.67
172	13,560	H_3	15.05	15.14
177	18,350	H_2	21.55	21.37

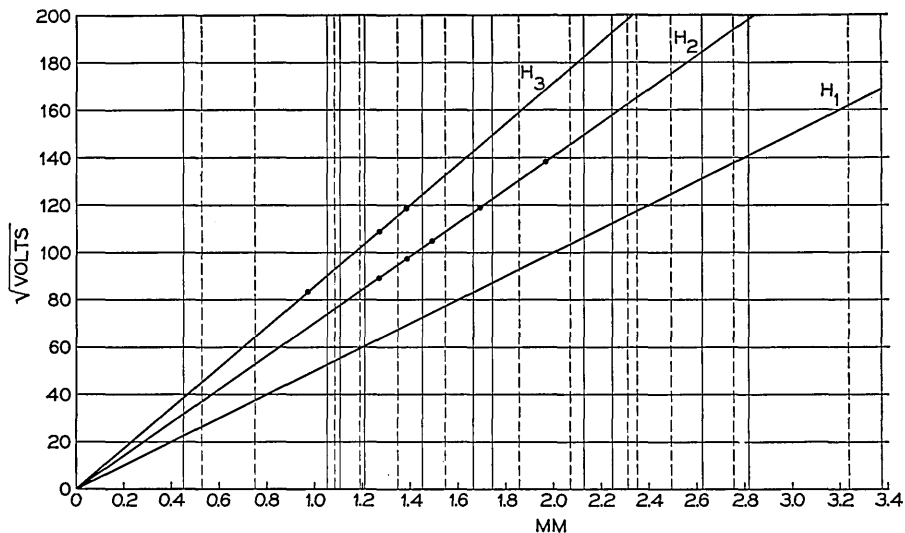

FIG. 12. Chief molecular spectrum lines of hydrogen in the neighborhood of $H\beta$. Lines to blue side shown full, to red side, dashed.

north, south, east and west, and using a voltage of approximately 18,000. These experiments showed at once that there is a shift of the center of the gravity of the displaced lines, that is, a change of frequency of the light emitted from the canal-ray particles. They showed that this shift was of the order of magnitude to be expected from the theory, and that it was independent of the direction of the apparatus.

An additional experiment made at this stage of the investigation was a test of the possible effect of a magnetic field. Due to the iron of the apparatus, a magnetic field existed at the tube which was fairly constant in direction with respect to the tube, and in amount. This field was neutralized by properly placed coils, and then replaced by one of approximately ten times its strength in the opposite direction. No effects of this variation of the magnetic field were found.

Final results

The final series of plates were then made with the apparatus in one position, using special Eastman type III-J plates which are of fine grain, but of a low speed, requiring all-day exposures. In this series seven different voltages were used ranging from 6788 to 18,356, adjusting as above described to locate the displaced lines in the regions of the spectrum free from molecular lines.

These plates gave eight points for measurement, three due to H_3 and five to H_2 .

The results are shown in Table III and Figs. 13 and 14. In the table, computations of the expected shift ($\Delta'\lambda$) are made in two ways. In column 4 the quantity $\lambda_0(\frac{1}{2}V^2/c^2)$, which should equal $\Delta'\lambda$, is computed from the values of V/c as derived from the voltage between the electrodes. From the fundamental equation connecting voltage and displacement it appears that since V^2/c^2 is proportional to voltage, $\Delta'\lambda$ so computed should be proportional to voltage, the factor of proportionality being different for the particles of different masses. In Fig. 13 the computed values for H_2 and H_3 are shown by the dashed lines, and the observed values, $\Delta'\lambda$ (6th column) by the circles and dots. These lie along the theoretical straight lines to within the probable errors of the measurements.

TABLE II.

PLATE NUMBER	DIRECTION OF DISCHARGE	OBSERVED SHIFT	$\lambda_0(\frac{1}{2}V^2/c^2)$ COMPUTED FROM OBSERVED V/c
136	N	0.036A	0.0472A
137	N	.052	"
138	S	.050	"
139	E	.045	"
140	W	.051	"
141	W	.047	"
		Mean 0.0468A	0.0472A

In column 5 values of $\Delta'\lambda$ are computed using the observed values of $\Delta\lambda (= V/c)$. This method of computation involves no knowledge of the voltages used, and so is independent of any errors of voltage measurement. The $\Delta'\lambda$'s so computed are shown, plotted against $\Delta\lambda$, by the dashed curves in Fig. 14, and the observed values are again shown by the circles and dots. The agreement is within the probable errors of the measurements, and the results are not significantly different from those plotted in Fig. 13, as should indeed be the case because of the close agreement of the Doppler shifts ($\Delta\lambda$) with the values computed from the voltages.

The conclusion drawn from these experiments is that the change of frequency of a moving light source predicted by the Larmor-Lorentz theory is verified.

DISCUSSION

Characteristics of results

The results graphically exhibited in Figs. 13 and 14 appear to be a satisfactory confirmation of the Larmor-Lorentz theory. It is proper, however, to note features of the experiment and the results which might be improved in further work. Probably the least satisfactory feature is that the displacements of center of gravity which constitute the evidence for the change in frequency are in every case less than the known separation of the components of the $H\beta$ line. This leaves the possibility that some of the observed shift could be due to a variation of relative intensity of these components, under the excitation conditions holding in the tubes. This variety of error could be excluded if voltages at least twice and preferably several times the highest here used could be employed. Radical changes in tube design would

TABLE III.

PLATE	VOLTAGE	LINE	$\lambda_0(\frac{1}{2}V^2/c^2)$ COMPUTED FROM VOLTAGE	$\lambda_0(\frac{1}{2}V^2/c^2)$ COMPUTED FROM OBSERVED $\Delta\lambda$	$\Delta'\lambda$ OBSERVED
169	6,788	H ₃	0.0116	0.0109	0.011A
160	7,780	H ₂	.0203	.0202	.0185
163	9,187	H ₂	.0238	.0243	.0225
170	10,574	H ₂	.0275	.0280	.027
165	11,566	H ₃	.0198	.0203	.0205
172	13,560	H ₂	.0352	.0360	.0345
172	13,560	H ₃	.0233	.0237	.0215
177	18,350	H ₂	.0478	.0469	.047

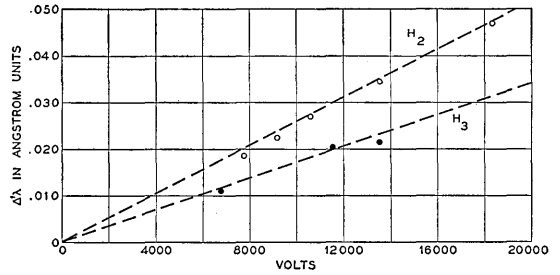

FIG. 13. Computed and observed second-order shifts, plotted against voltage.

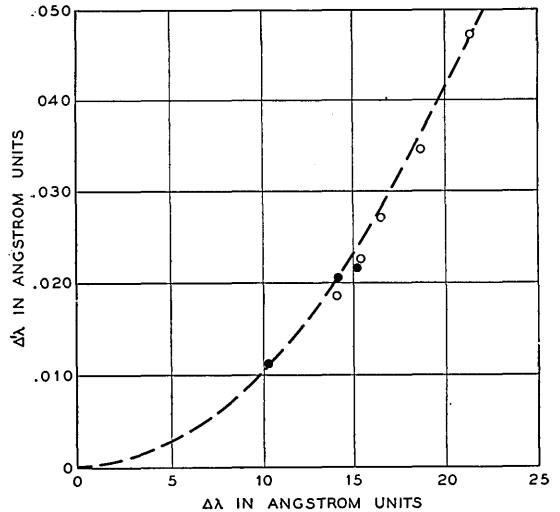

FIG. 14. Computed and observed second-order shifts, plotted against first-order (Doppler) shifts.

be necessary to permit these without a breakdown of the gap between electrodes. A possibility here is provision for continuous pumping to hold the pressures different in different parts of the tube. The same result, without the necessity for such high voltages, could be secured if the single mass particles H₁ could be produced, as these should give twice the shift of the H₂ particles. We have, following suggestions in the literature, tried the introduction of water vapor, and admixtures of helium and neon, but without success.

The lack of positive assurance that the canal-ray particles do actually emit the same frequency, despite changes of voltage and pressure conditions has already been dwelt on. Insofar as explaining the shifts of the center of gravity by a changing frequency of the *undisplaced* line, this appears very unlikely when the results are

plotted for the two kinds of particles at the same voltages, as is done in Fig. 13. If these shifts were due wholly or in part to a change in the center line, the shifts for both kinds of particles would be expected to be the same or to fall on lines inclined otherwise than this precise way. The possibility that the stationary and traveling H_2 and H_3 particles suffer changes of frequency due to collision processes which happen to follow exactly the relation expected from the Larmor-Lorentz theory from velocity changes alone, is remote, even though conceivable. The consistency of our results with the prediction of the theory, over a considerable range of velocities, and for two kinds of particles, can itself in the absence of any other known cause for the observed effect, be taken as evidence for their correctness.

Significance of results

This experiment forms the necessary optical complement to the Michelson-Morley experiment, and the more general form of this experiment due to Kennedy and Thorndyke. The null result of the latter experiment can be explained, on the assumption of a fixed luminiferous ether, by contractions of the apparatus along and across the direction of motion which are in a definite ratio to each other, namely $(1 - V^2/c^2)^{1/2} : 1$ where V is the velocity of the apparatus and c the velocity of light. From these experiments the contractions are unfixed in absolute amount; i.e., the contractions in the two directions could be $1 - V^2/c^2$ and $(1 - V^2/c^2)^{1/2}$, etc. For each absolute contraction, there is demanded in general a change in the rate of the clock at the origin of

the light signals, and an independent experiment must furnish this rate in order to completely solve the problem. The present experiment establishes this rate as according to the relation

$$\nu = \nu_0(1 - V^2/c^2)^{1/2},$$

where ν_0 the frequency of the clock when stationary in the ether, ν its frequency when in motion. It follows then on combining this result with the results of the Kennedy-Thorndyke experiment that the dimensions of the moving apparatus are contracted by the factor $(1 - V^2/c^2)^{1/2}$ in the direction of motion, and are unaffected at right angles to that direction.

The Michelson-Morley experiment and Kennedy-Thorndyke experiments, yielding null results, could, of themselves, be equally well explained—and more simply—by assuming an ether entrained by the earth, or a ballistic character of light emission, instead of assuming two concealed conspiring compensations—contractions of dimensions and of clock rates. The present experiment, giving a positive instead of a null result may hence be claimed to give more decisive evidence for the Larmor-Lorentz theory than is given by the experiments which have yielded null results.

The discussion of the consequences of this change in clock rate, the reality of which may be taken as established by this experiment, consists practically of the entire theory of the optics of moving bodies as developed by Larmor and Lorentz. Some of the special consequences of the use of clocks which behave in this way when in motion have been developed in earlier papers of this series.¹